

bluecool!
blue line

FLAT

12/24 V.



Instrucciones de Montaje

Mounting Instructions

Instructions de Montage

Montageanweisungen

Istruzioni di Montaggio

ES Spanish

EN English

FR French

GE German

IT Italian

**RECOMENDACIONES
PARA EL MONTAJE**

- Antes de iniciar el montaje leer las instrucciones y seguirlas durante el proceso de instalación.
- Usar las herramientas adecuadas para cada operación.

ELECTRICIDAD

- Desconectar la llave de contacto.
- Desconectar la batería antes de empezar el montaje.
- Asegurar el conexionado de los componentes eléctricos, verificando su correcto encaje.

Herramientas

Juego de Llaves Torx
Juego de Llaves Allen
Llave fija 10, 13, 14
Tijeras
Flexómetro

DOCUMENTACIÓN QUE EL EQUIPO INCLUYE:

- Instrucciones de Montaje: 220.AA7.0001
- Manual del Usuario: 220.AA7.0003
- Diagnóstico de Averías: 220.AA7.0004
- Garantía: 220.AA1.0010

ATENCIÓN :

Al instalar el equipo evaporativo en el techo se debe proteger la parte superior de la cabina con un paño ó manta protectora para evitar posibles arañazos. Al instalar Bycool Flat en el techo hay que tener en cuenta que, normalmente, las cabinas que vienen provistas de escotilla, tienen una estructura suficiente para soportar el peso del equipo. Sin embargo, cuando no ocurra así y sea necesario realizar corte en el techo ó incluso si en el caso de llevar escotilla el material no es lo suficientemente resistente (caso de techo de fibra, plástico, etc...) es el instalador el que debe decidir, bajo su responsabilidad, sobre la necesidad de reforzar el techo para evitar posibles deformaciones, roturas, entradas de agua, etc... habilitando los medios para que esto no ocurra.

ADVERTENCIAS :

- La pieza nº 17 del listado de Piezas Suministradas debe ser sustituida cada 12 meses.
- **dirna Bergstrom, s.l.** queda exenta de responsabilidad si se producen averías que procedan de una inadecuada manipulación ó instalación del equipo, ó por modificaciones y sustituciones efectuadas sin nuestra expresa autorización por escrito.
- Véase **procedimiento de garantía** del producto incluido en **Diagnóstico de Averías**.
- Véase **Manual de Usuario** del equipo para el correcto funcionamiento del mando a distancia y del panel de control.

1 Desmontar tapa escotilla, los elementos de fijación y entregar éstos al cliente (*).



1a En el caso de no existir escotilla, dar corte en techo con las dimensiones mínimas indicadas.

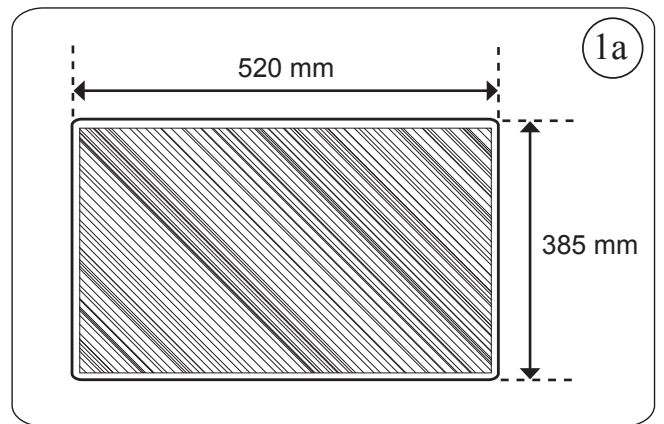

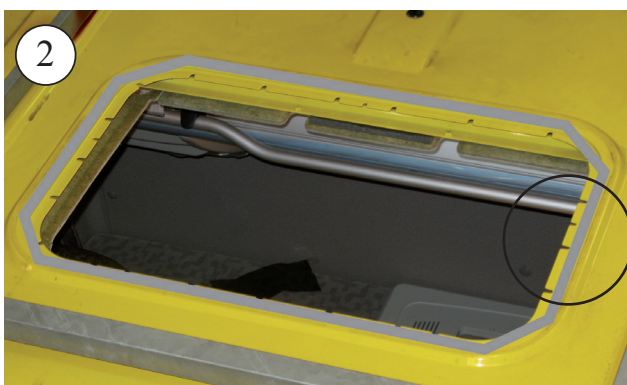

Dimensiones mínimas de corte en techo de cabina si no lleva escotilla

2 Quitar los residuos sobrantes adheridas al techo antes de pegar la junta EPDM.

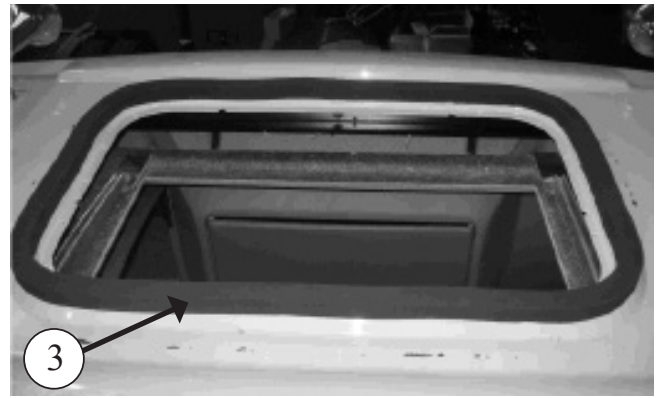

3 Pegue la junta EPDM alrededor del hueco de escotilla (*mirar el detalle para cortar los bordes finales de unión de la junta*).



 **COMO CORTAR LA JUNTA EPDM PARA EVITAR FILTRACIÓN DE AGUA EN LA CABINA**

A- Pegar la junta, manteniendo 100 mm de papel protector por cada lado.

B- Quita los dos piezas de papel.

C- Pegue presionado ambos finales.

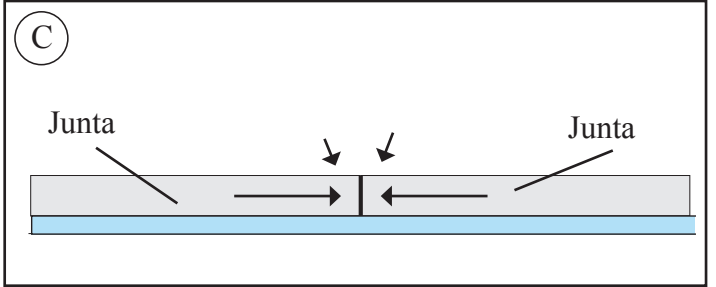
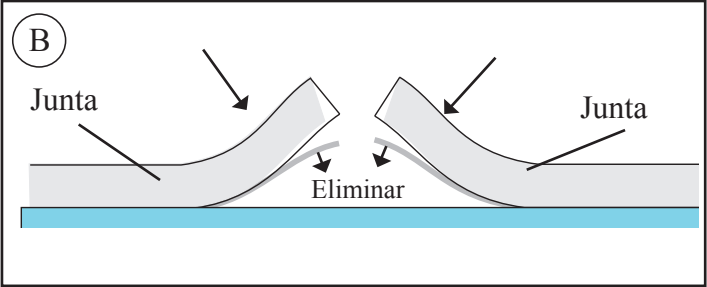
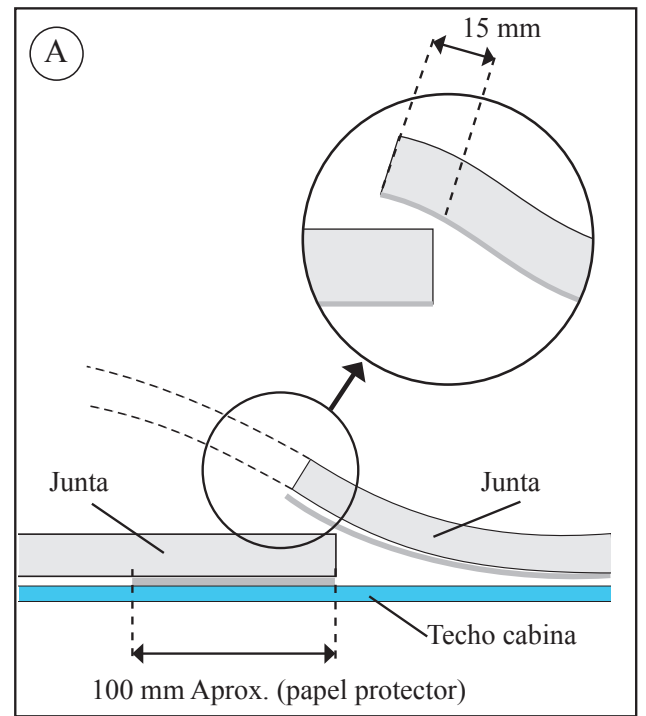

4 **EXTERIOR CABINA:**
 Posicionar el Bycool en el hueco de la escotilla.

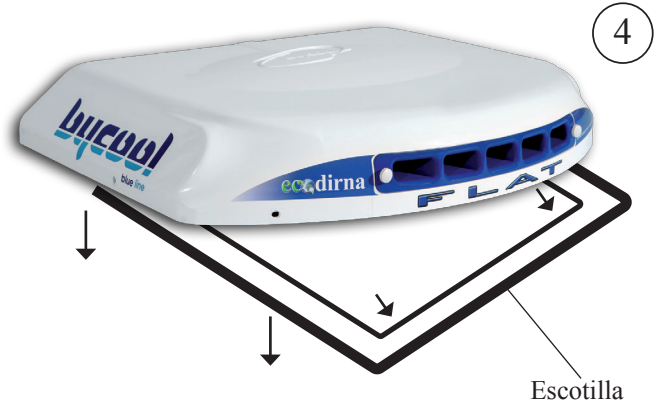

5 **INTERIOR CABINA:**
 Roscar 5 mm aproximadamente (4) espárragos 8/125x100 ó 120, la medida se elegirá tras presentar los soportes de sujeción y teniendo en cuenta que los espárragos deben sobresalir de los mismos por la parte inferior unos 10 mm.

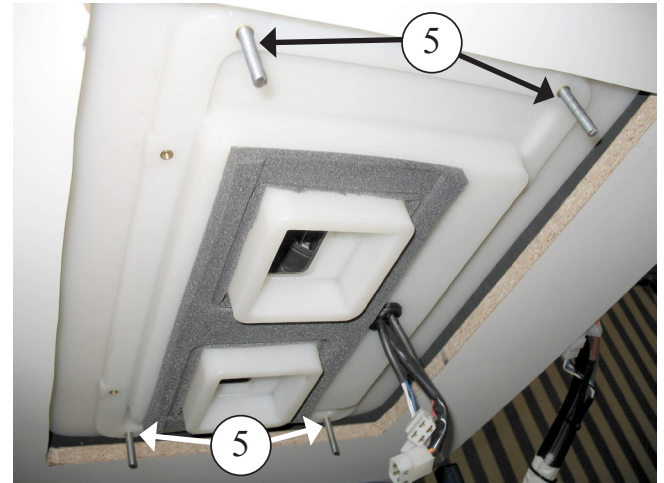
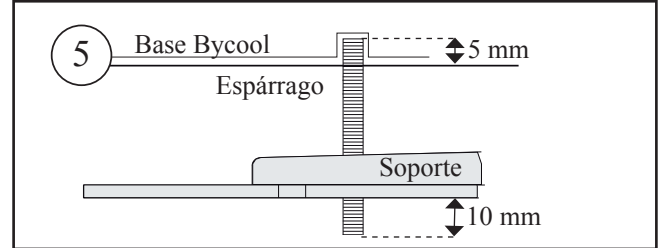

6 Colocar (1) arandela Ø 7 de goma, (1) arandela plana Ø 8 ala ancha, (2) tuerca M8 y (1) arandela plana Ø 8 ala ancha , en cada uno de los espárragos anteriores.

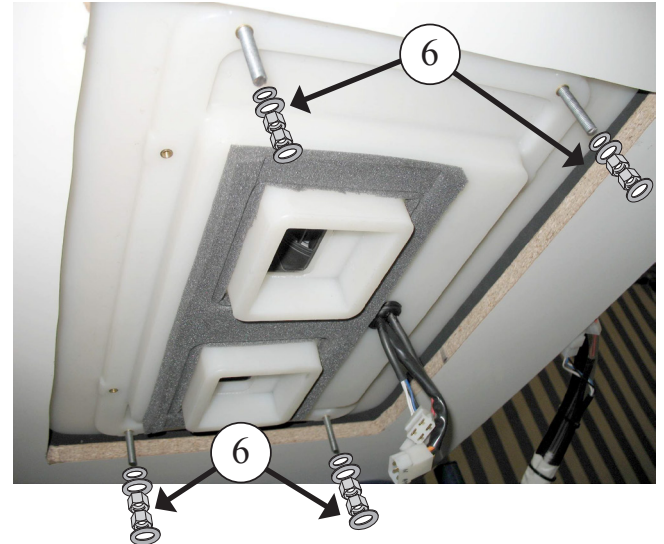

6a Colocar (2) soportes sujeción, con (1) arandela y (1) tuerca autoblocante M8, **sin llegar a apretar.**



7 Roscar 10 mm (4) espárragos M6 x 55 o 80, donde se indica, dependiendo de la altura (A) del esquema del punto 9.

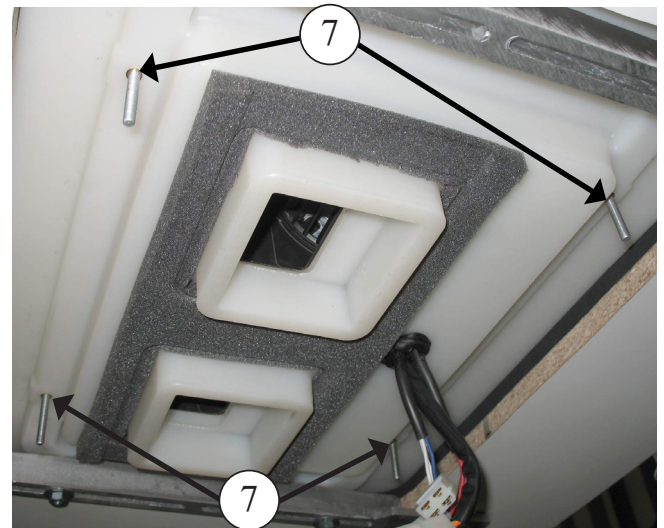

8 Colocar (1) arandela Ø6 de goma, (1) arandela plana Ø6 ala ancha y (1) tuerca M6, sobre cada uno de los espárragos de M6. **Apretar tuerca.**

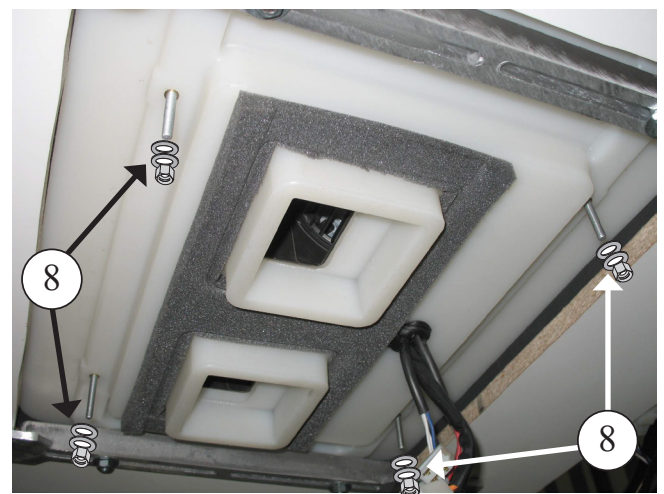

8a Colocar (1) tuerca M6 **sin apretar** en cada espárrago.

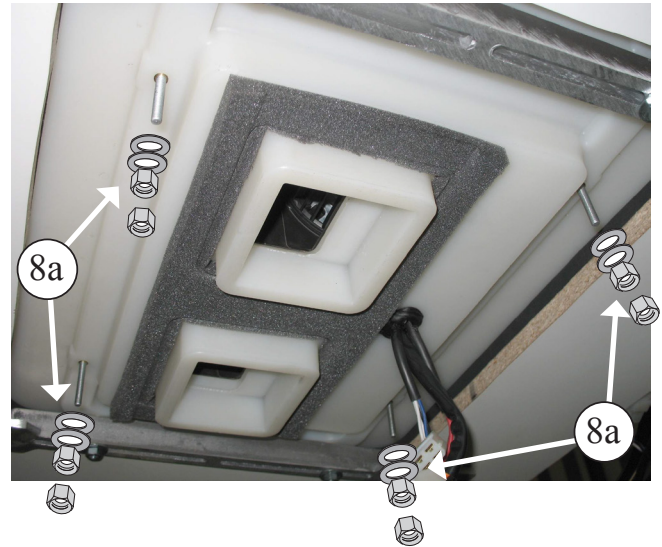

8b Pegar los canalizadores al panel interior de distribución de aire utilizando LOCTITE superglue 3 o similar, para facilitar el montaje del conjunto y asegurar los flujos de aire fríos por las lumbreras.

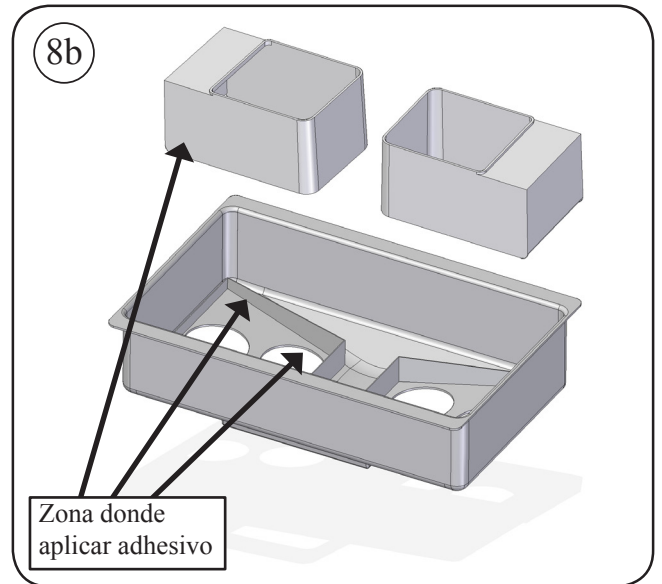

8c Conectar las (2) cajas de 4 vías y (1) de 2 vías, del panel interior de distribución de aire, con las del Bycool.

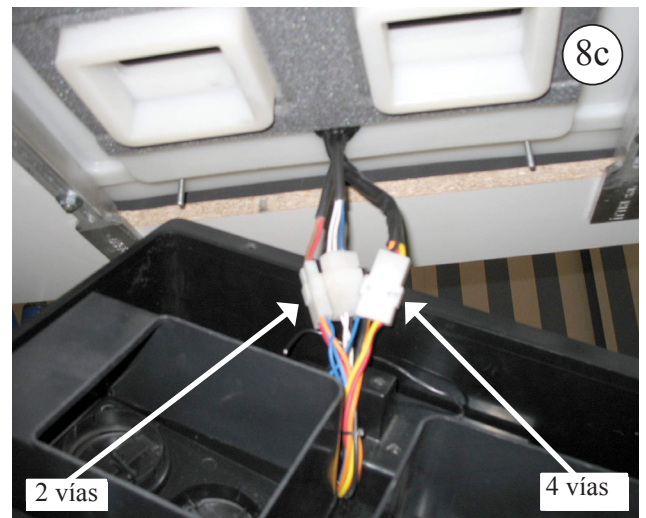

9 Colocar panel interior de distribución de aire en los espárragos anteriores con (1) arandela M6 ala ancha y (1) tuerca M6 en cada espárrago. Apretar tuercas hasta que los canalizadores hagan tope en goma espuma superior del equipo.

Importante: Los canalizadores deben hacer tope contra la goma espuma para evitar fugas de aire.

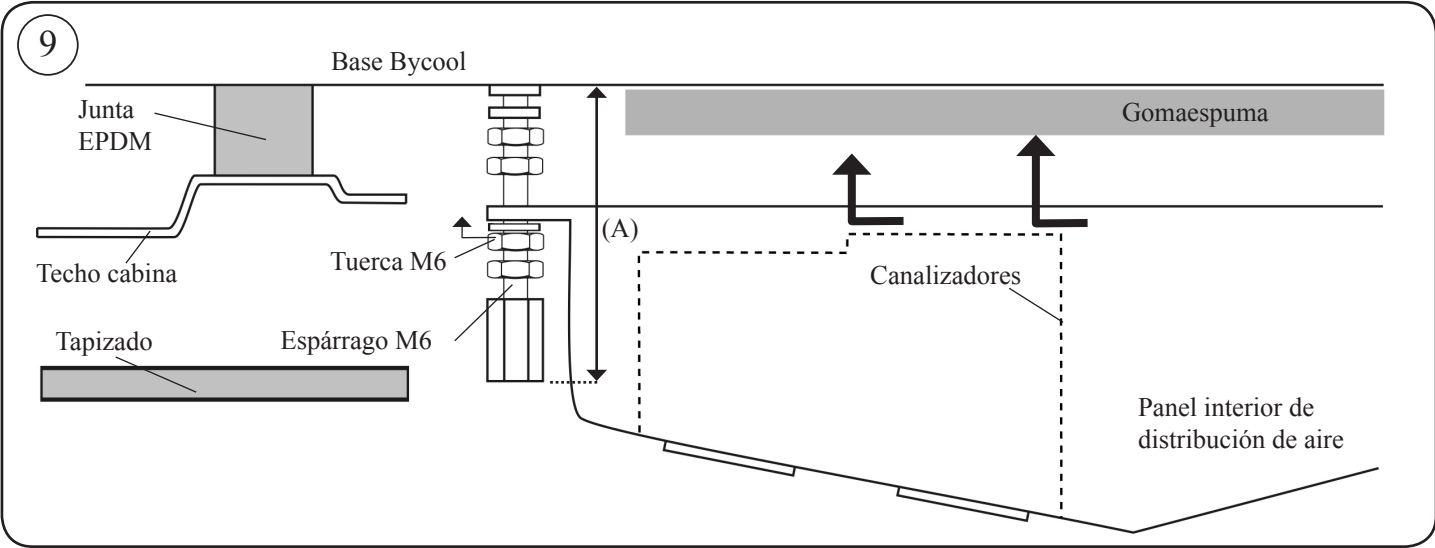

10 Apretar tuerca del punto 6a hasta hacer tope con la parte superior del panel interior de distribución de aire.

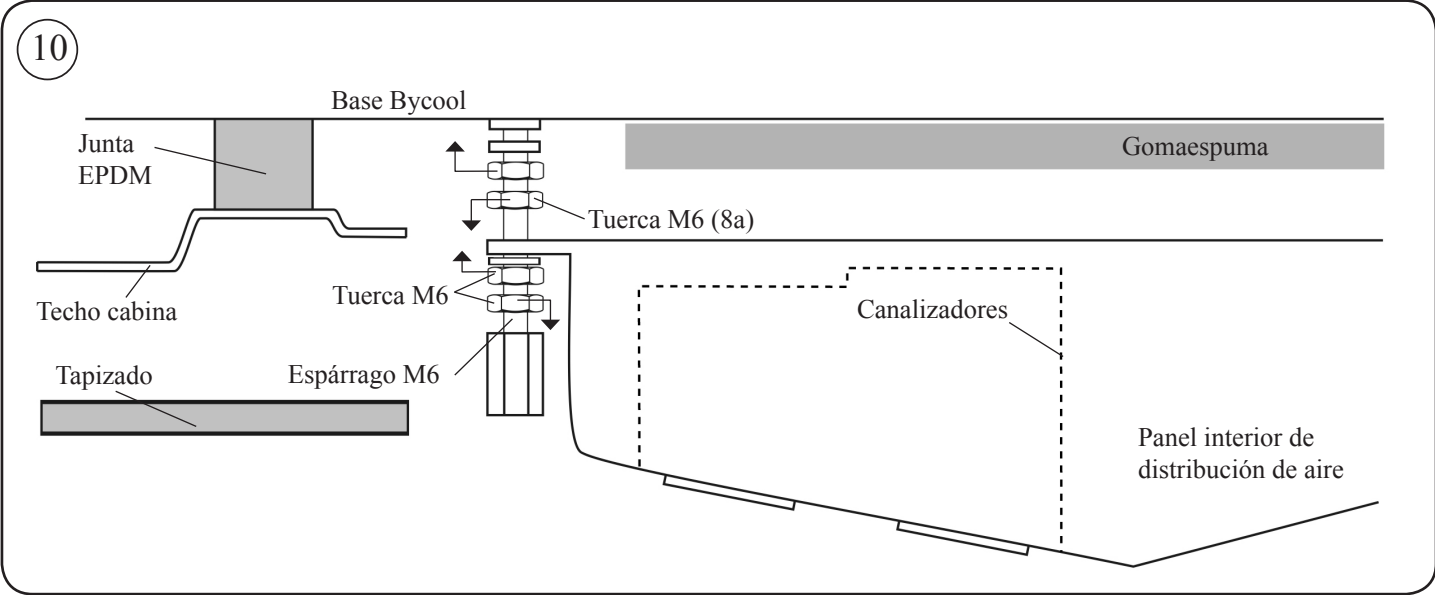

11 Presentar consola y centrar el equipo en el sitio más conveniente del techo de la cabina. Una vez centrado quitar consola.

12

Fijar los soportes de sujeción apretando las tuercas hasta el apriete de la junta de EPDM exterior del equipo entre 3 y 6 mm.

Importante: Para evitar posibles filtraciones de agua al interior de la cabina se debe asegurar el apriete de la junta EPDM con la base del Bycool tal y como se indica en el **esquema**.

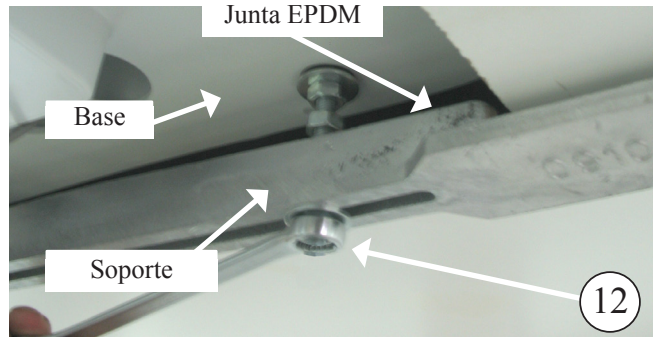
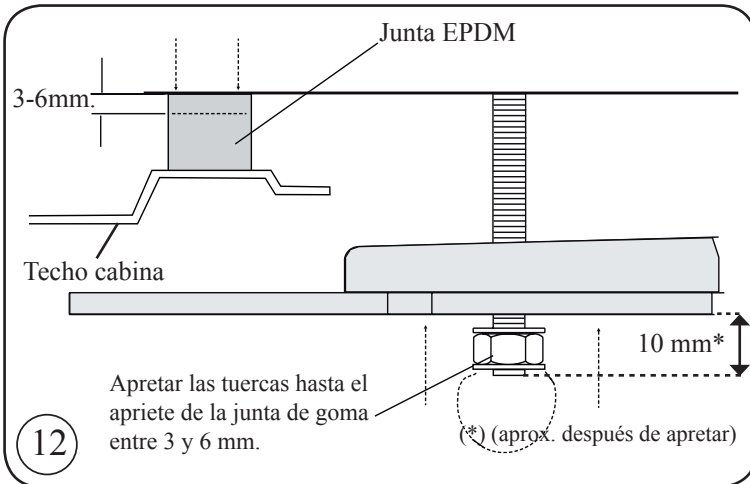

13

Apretar (4) tuercas M8 al soporte y (4) a la base del Bycool.



14 Colocar tuerca M6 (A) tras la tuerca de fijación del panel interior de distribución de aire en cada espárrago. Colocar hexágonos M6 roscándolo hasta que quede 1 mm por encima del tapizado. Desenroscar tuercas M6 (A) de este punto hasta que haga tope con los hexágonos y apretar contra estos.

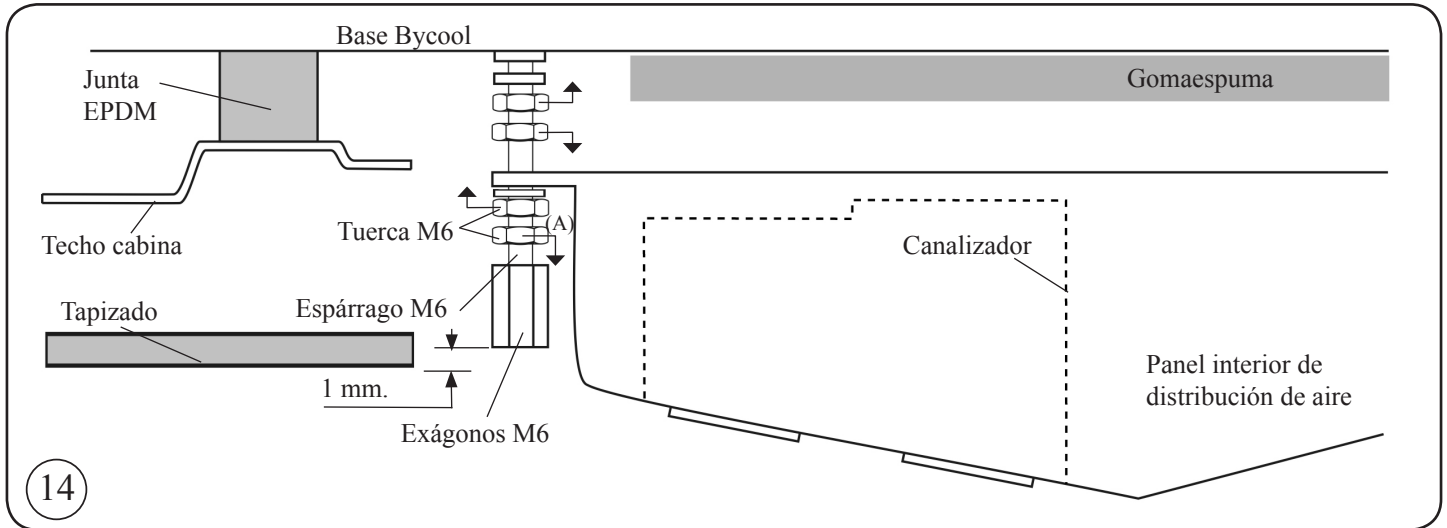
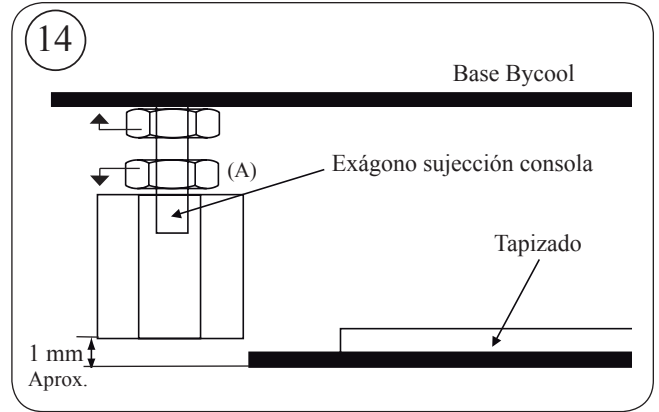

15 Colocar la consola con (4) tornillos M6/100x15 allen.

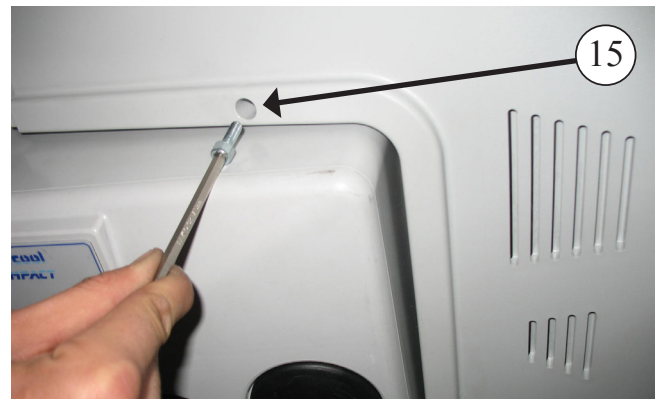

15a Cubrir los (4) tornillos M6/100x15 allen con los embellecedores redondos de M6 de plástico.

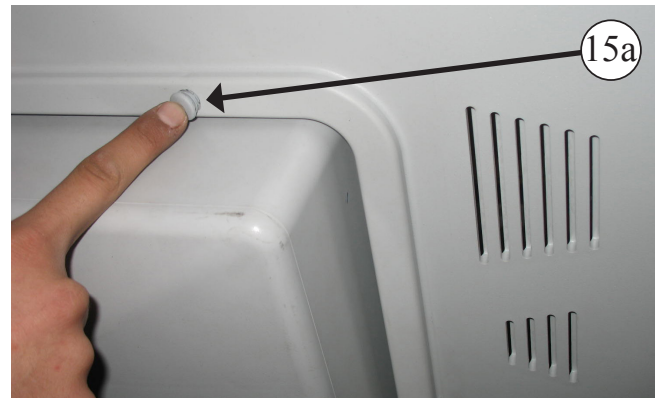

Vista explosionada hasta la fijación de los soportes

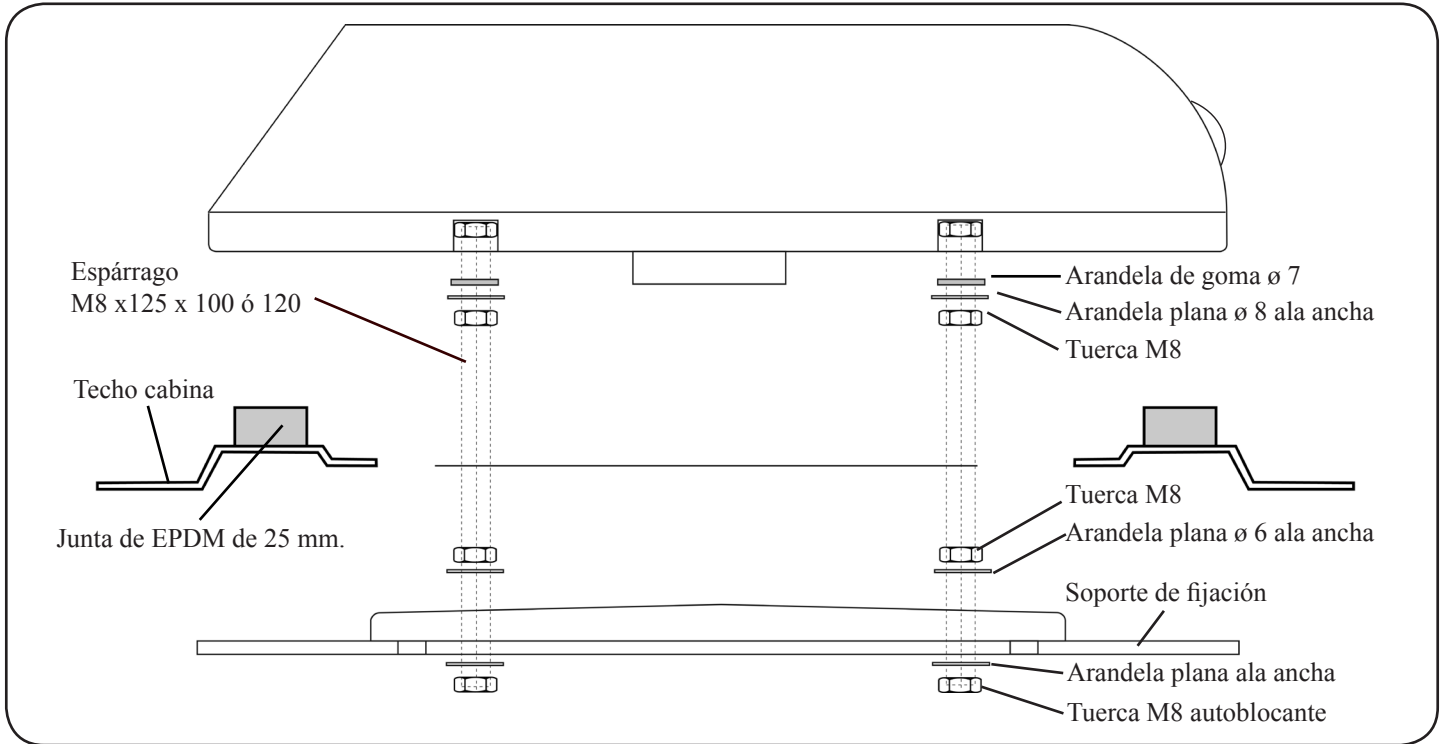

Vista explosionada hasta la fijación de las consolas

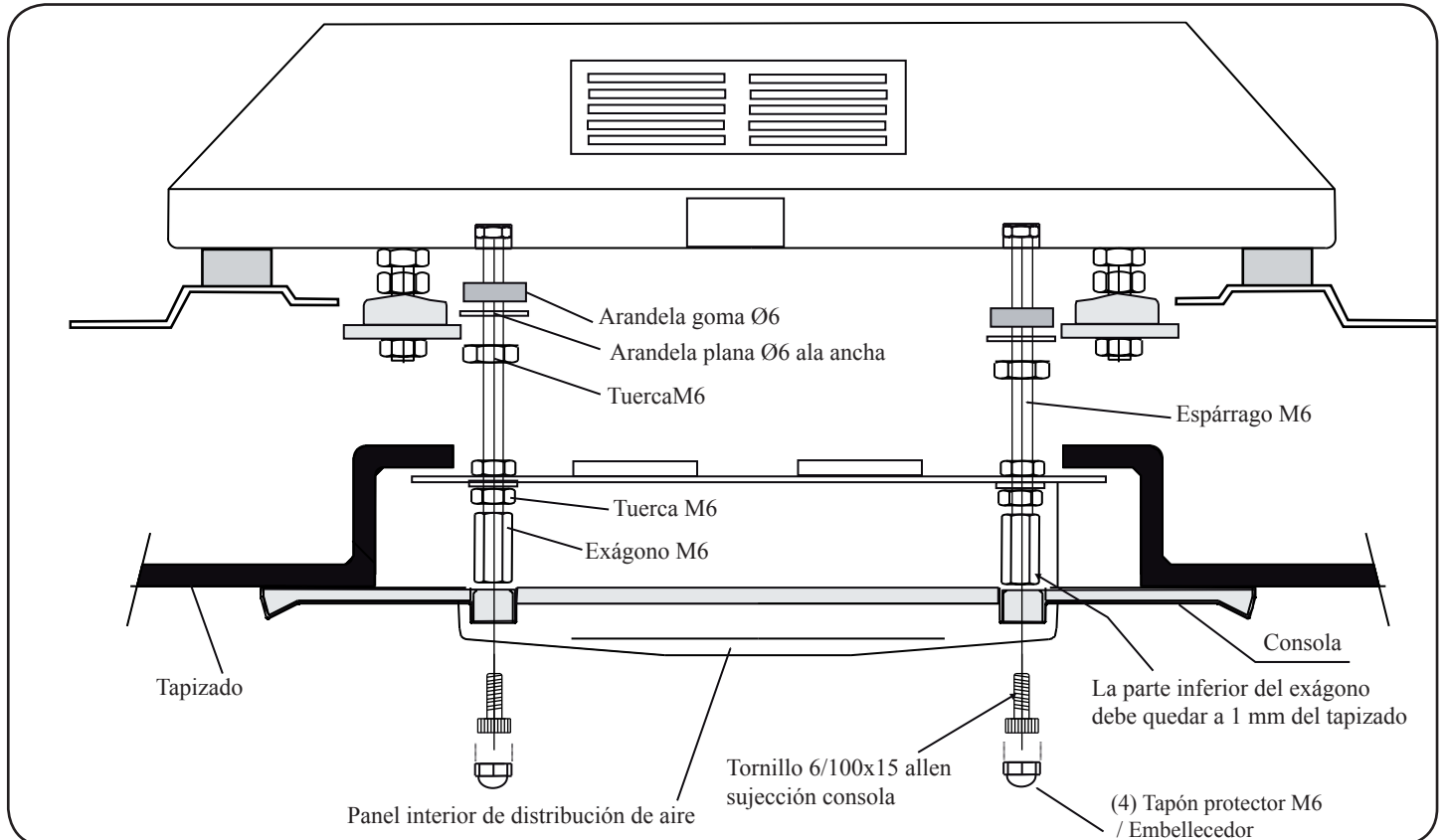

16 Conectar cajas cableados y tubos, por la parte trasera del Bycool según se indica.

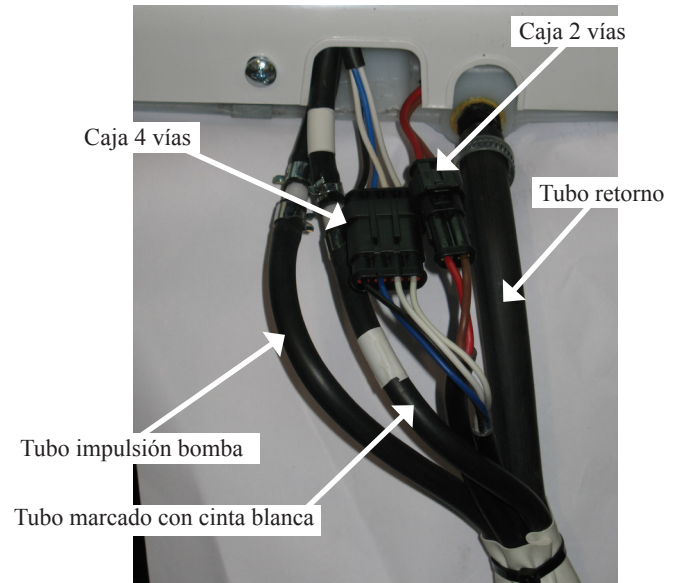

17 Posicionar soporte depósito en la parte baja más adecuada de la zona trasera de la cabina. marcar y taladrar Ø 9 en cabina teniendo en cuenta que la posición vertical del soporte. Mínimo (6) taladros de sujeción.



18 Colocar tuercas remache de M6 y fijar el soporte con tornillos 6/100x30.
(*) - En los casos que no apoye en parte lisa, colocar separador de 10mm y tornillo 6/100 x 40.

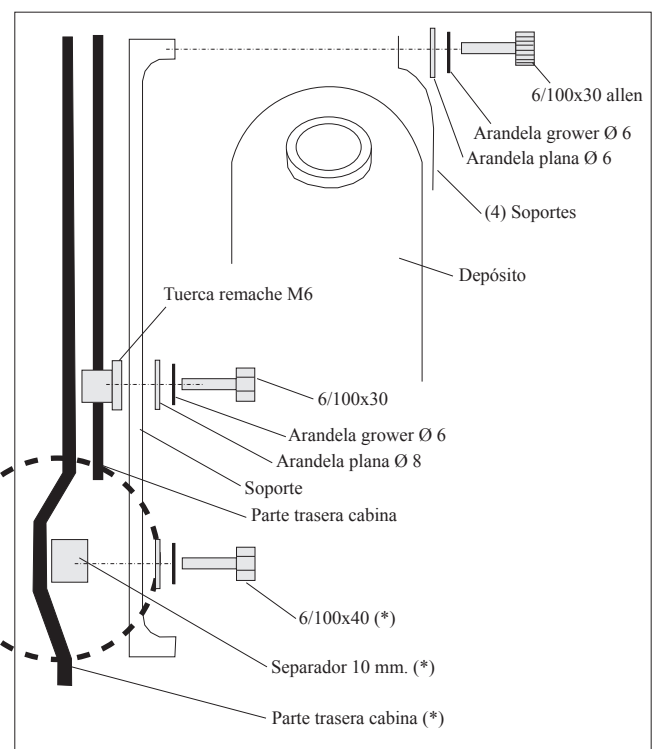

- 19** Fijar conjunto bomba al depósito con (2) tornillos rosca chapa 5.4x19 mm.



- 20** A continuación conectar tubo de bomba (X) a depósito y fijar depósito (*eligiendo mejor posición del tapón de llenado, derecha o izquierda, para facilitar el mismo*) con soportes suministrados. El soporte con resalte se coloca en caso de montar el depósito con el tapón de llenado (Y) al lado izquierdo.

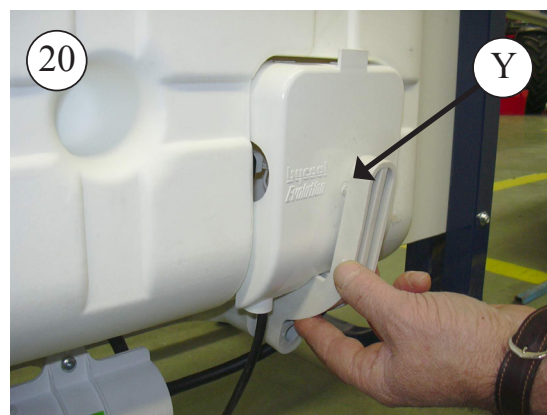
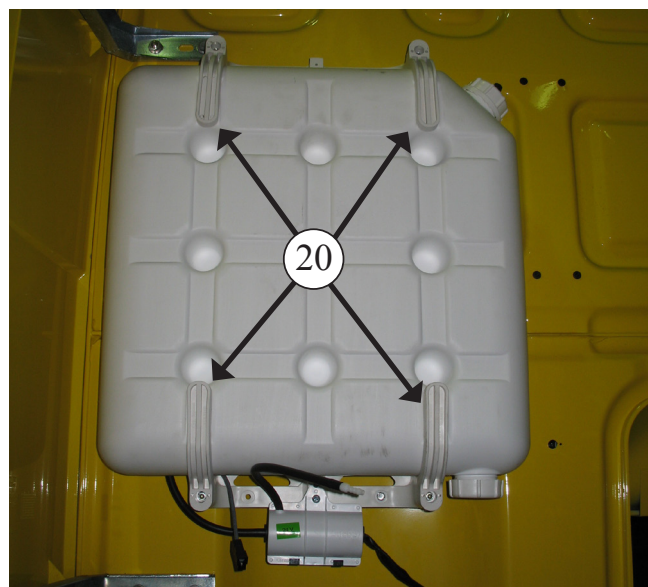

21 Montar filtro en tubo con espiga, introducir en el tapón y conectar a tubo de retorno Ø18 x Ø12 (A).

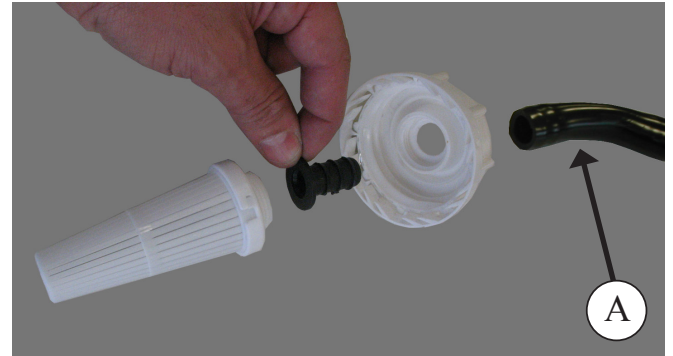

22 Colocar tapón en el depósito, cortar a 100mm; intercalar "T" y conectar a ésta el tubo de menor sección, **marcado con cinta blanca** y cerciorarse que el radio de la curva sea suficiente para evitar estrangulamientos.



23 Conectar cableado con funda a las cajas del evaporativo y tubo entrada de agua.

A. Conectar a la bomba el tubo de impulsión que viene desde el evaporativo.
 B. Conectar cableado bomba y el de nivel.

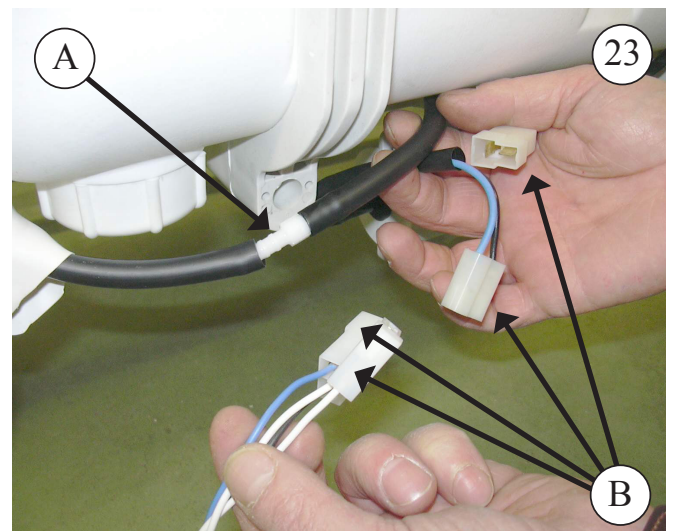

24

Conectar como se indica el cableado de batería.

**25**

Tubo de desagüe

(*) Manera correcta de instalación, donde el tubo de desagüe tenga caída evitando bucles y estrangulamientos, para facilitar la caída de agua al depósito.

(**) Manera incorrecta. No realizar.

(***) NO CORTAR cableado sobrante y sujetarlo (enrollado), detrás del depósito de agua.

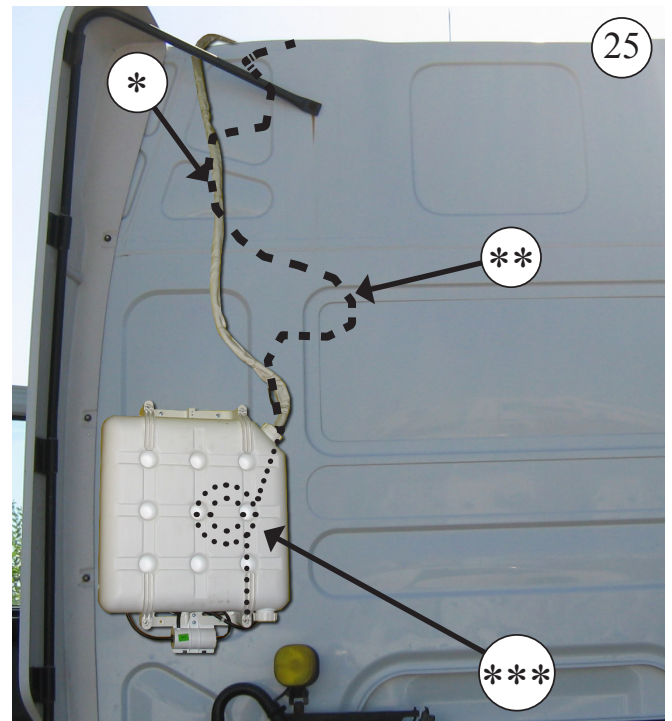

Importante:

El acondicionador evaporativo funciona tomando aire del exterior que es introducido en la cabina. Es esencial que este aire no se estanque en el interior, lo que produciría un exceso de humedad. Todas las cabinas de vehículos modernos van dotados de rejillas de renovación de aire, por los que sale el aire necesario. Por ejemplo, para la calefacción.

El instalador deberá cerciorarse de la existencia de estas rejillas y, en caso de no existir, deberá instalarlas.

Por su parte, el usuario deberá vigilar periódicamente que estas rejillas no estén obstruidas por suciedad.

Instrucciones detalladas sobre la instalación del cableado de alimentación



Cableado de alimentación



1- Llevar el cable de alimentación del equipo hasta la batería del vehículo, pegando los soportes de plástico en la parte posterior de la cabina y fijándolo con bridas; después con la cabina abatida pasar el cable por la parte inferior de la misma sujetándolo con abrazaderas y tornillos M4; y hasta la batería con bridas; se debe utilizar el mismo paso del cableado original. (Para pegar los soportes de plástico limpiar bien la zona antes). Al conectar el equipo a la batería éste hará un test en todos sus leds, y se apagará.

IMPORTANTE: Debido al complejo sistema de regulación electrónica del equipo, la toma de corriente debe realizarse directamente a la batería del vehículo, no a cualquier otro punto que dé servicio a otros accesorios del vehículo teniendo la precaución de no invertir la polaridad al realizar la conexión (2). Si se invierte la polaridad se pueden ocasionar daños irreparables en la electrónica no cubiertos por la garantía.

IMPORTANTE: Para la puesta en marcha consultar el Manual del Usuario.

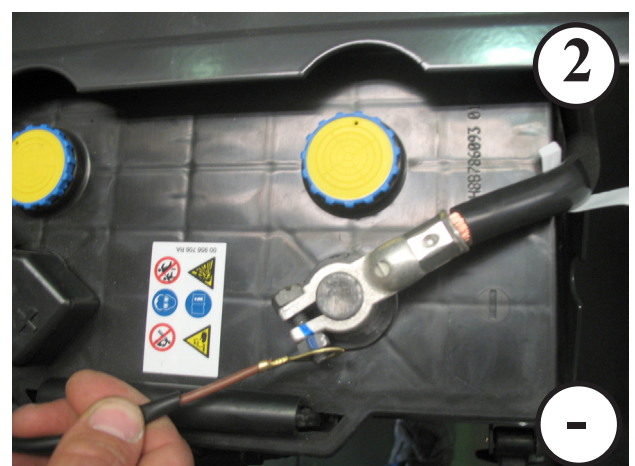

Esquema eléctrico

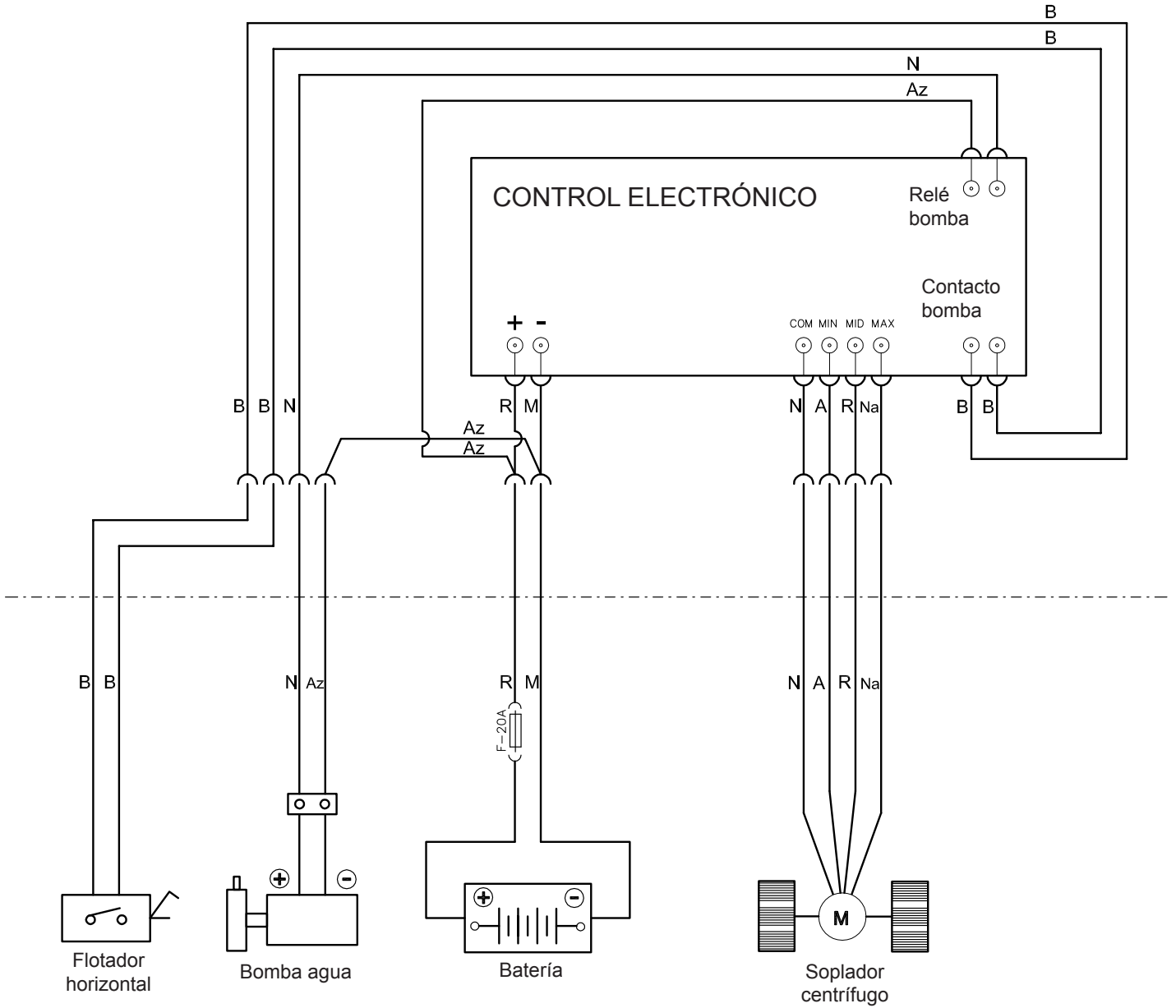

BOMBA AGUA FLOTADOR

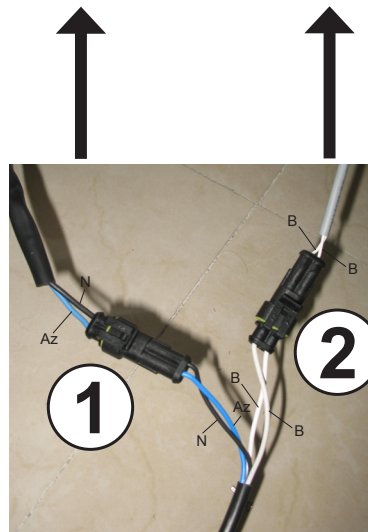

COLORES

A	Amarillo
Az	Azul
B	Blanco
G	Gris
Na	Naranja
N	Negro
R	Rojo
Ro	Rosa
V	Verde
Vi	Violeta
M	Marrón
Mo	Morado

**RECOMMENDATIONS
FOR ASSEMBLY**

- Before starting the assembly read the instructions and follow them during the installation process.
- Use suitable tools for each operation.

ELECTRICITY

- Switch off the ignition key.
- Disconnect the battery before starting the assembly.
- Secure the connection of the electrical components by checking that they fit correctly.

Tools

- | |
|--------------------|
| Torque Wrench set |
| Allen Wrench Set |
| Spanner 10, 13, 14 |
| Scissors |
| Tape Measure |

DOCUMENTATION WHICH COMES WITH THE EQUIPMENT:

- Assembly Instructions: 220.AA7.0001
- User Manual: 220.AA7.0003
- Troubleshooting: 220.AA7.0004
- Guarantee: 220.AA1.0010

WARNING :

When installing the evaporative unit in the ceiling, protect the upper part of the cabin with a cloth or sheet to prevent scratching. When installing Bycool Flat in the ceiling, bear in mind that cabins are normally fitted with a hatch and have a structure which can withstand the weight of the unit. However, if this is not so and it is necessary to open up the ceiling, or should the hatch material not be sufficiently resistant (e.g. fibre, plastic, etc) the installer must decide, under his sole responsibility, on the need to reinforce the ceiling in order to prevent deformation, breakage, incoming water, etc, and use the means necessary to this end.

WARNINGS :

- Part no. 17 from the List of Parts Supplied must be replaced every 12 months.
- **Dirna Bergstrom, s.l.** will not be held responsible for any faults arising from inappropriate handling or installation of the equipment, or due to modifications or replacements carried out without our written authorisation.
- See **guarantee procedure** for the product included in **Troubleshooting**.
- See the equipment **User Manual** for the correct operation of the remote control and the control panel.

1 Dismount hatch cover and the fastening items and give these to the customer (*).



1a In case there is no hatch, cut roof according to minimum indicated measures.

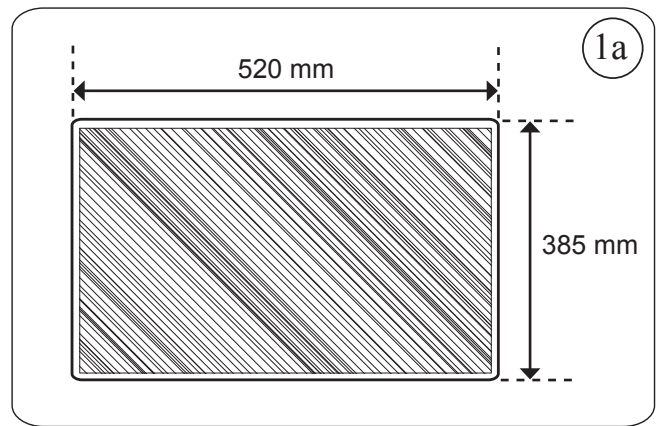

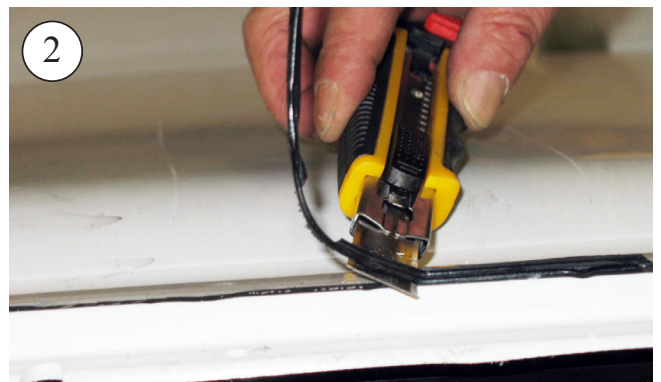
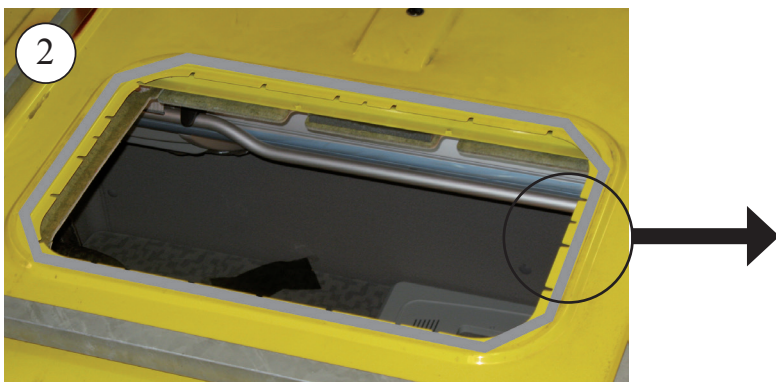

Minimum dimensions to be cut in cabin roof if hatch not included

2 Remove any excess material stuck to the roof before sticking the EPDM seal.

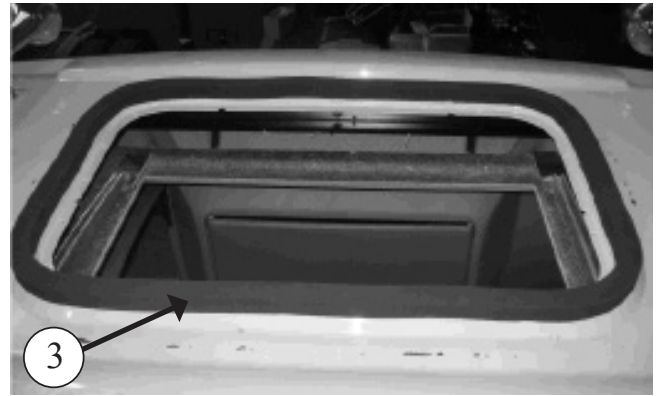

3 Stick the EPDM seal around the hatch gap (check the drawing for cutting the edges of the gasket seal).



 **HOW TO CUT THE EPDM SEAL TO AVOID WATER LEAKING INTO THE CAB**

A- Stick the seal, keeping 100 mm of protection paper on each side.

B- Remove the two pieces of paper.

C- Stick by pressing both ends.

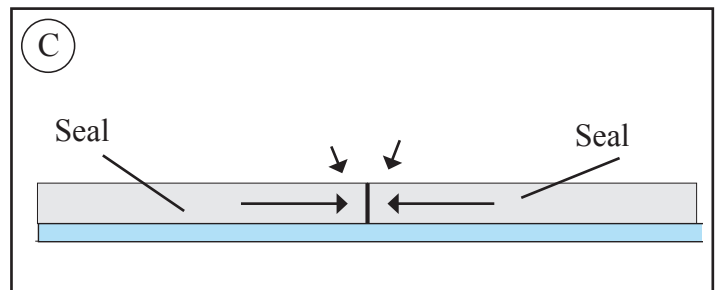
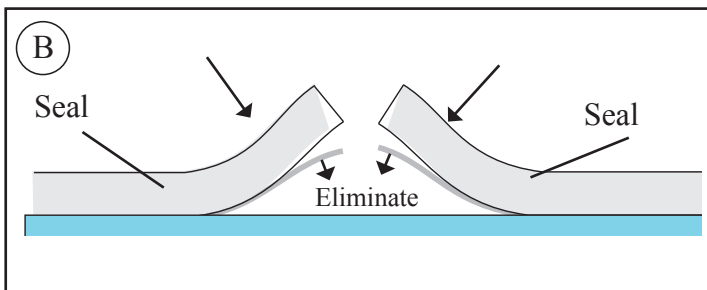
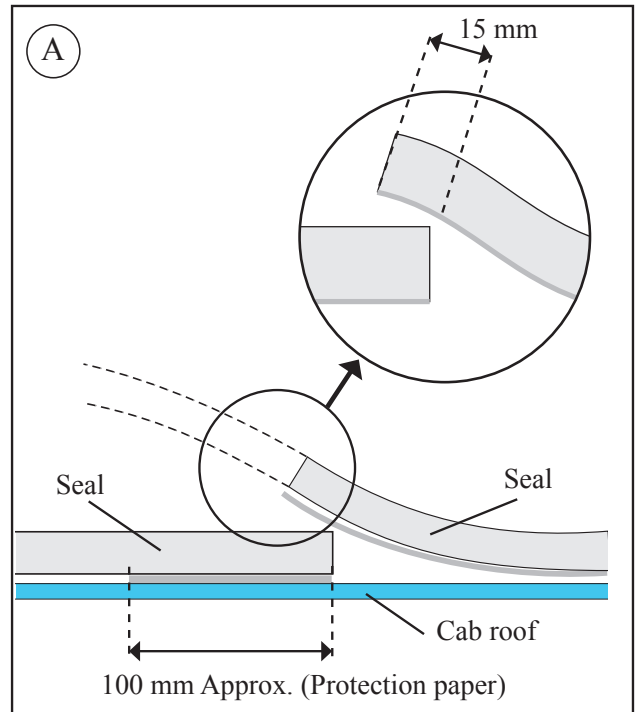

4 **OUTER CAB:**
Place the Bycool in the hatch gap.

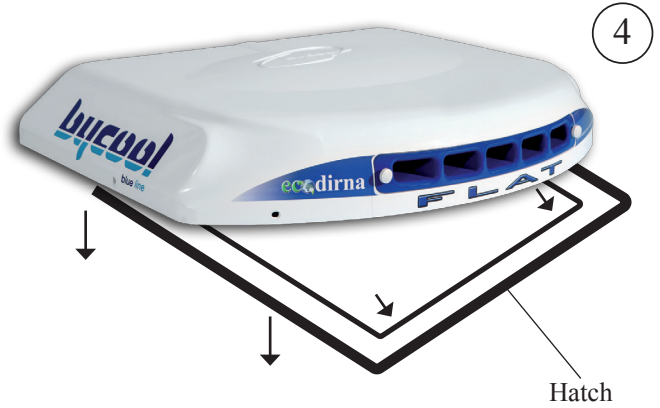

5 **INSIDE CAB:**
Thread (4) stud bolts 8/125x100 or 120 mm approximately 5 mm, choose the measurement after placing the fastening supports and bearing in mind that the stud bolts should protrude from the bottom part by some 10 mm.

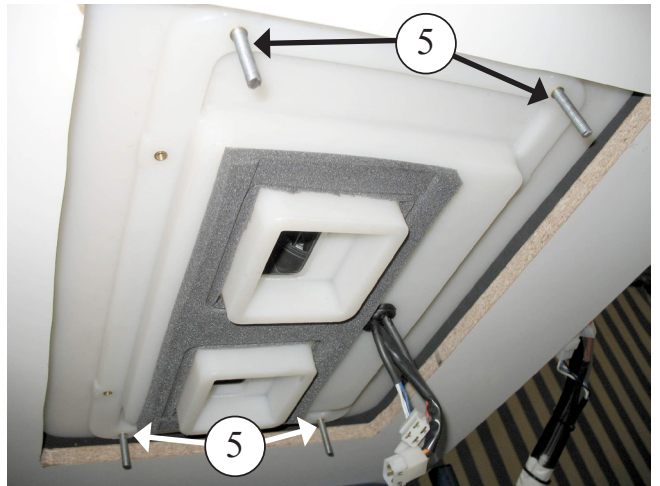
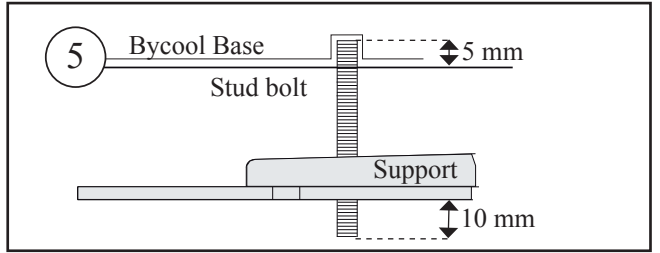

6 Place (1) rubber washer Ø 7 , (1) wide-flange flat washer Ø 8, (2) M8 bolts and (1) flat Ø 8 flat flange , on each one of the previous bolts.

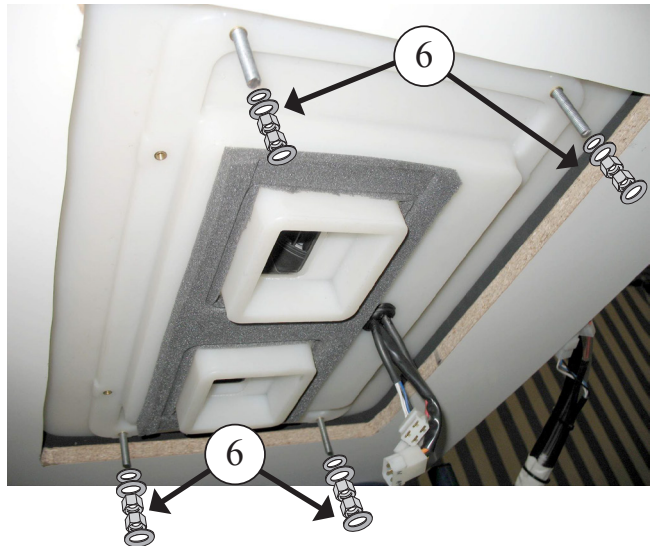

6a Place (2) fastening supports, with (1) washer and (1) self-locking nut M8, **do not tighten**.



7 Thread (4) stud bolts M6 x 55 or 80, 10 mm where indicated, depending on the height of (A) in drawing for point 9.

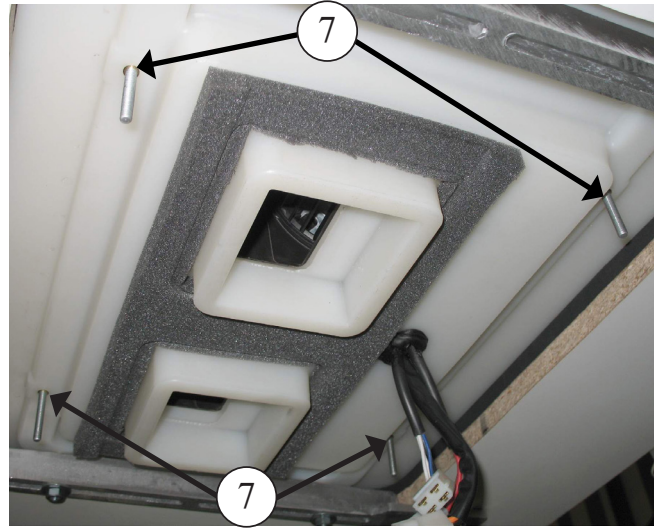

8 Place (1) rubber washer Ø6, (1) wide-flanged washer Ø6 and (1) M6 nut, on each one of the M6 stud bolts. **Tighten nut.**

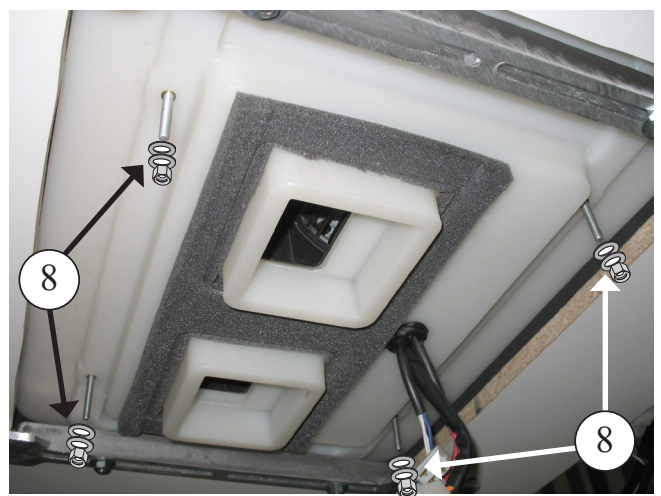

8a Place (1) M6 nut on each stud bolt **do not tighten**.

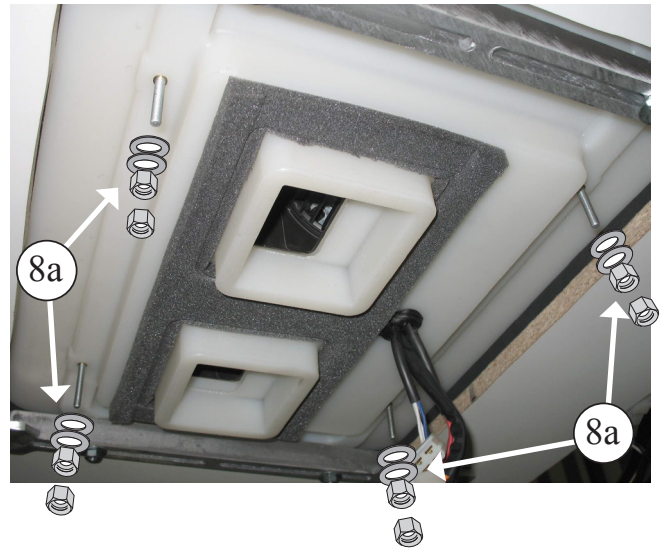

8b Attach the ducts to the interior air distribution panel using LOCTITE Superglue 3 or similar, in order to facilitate the assembly of the equipment and ensure the flows of cold air through the louvres.

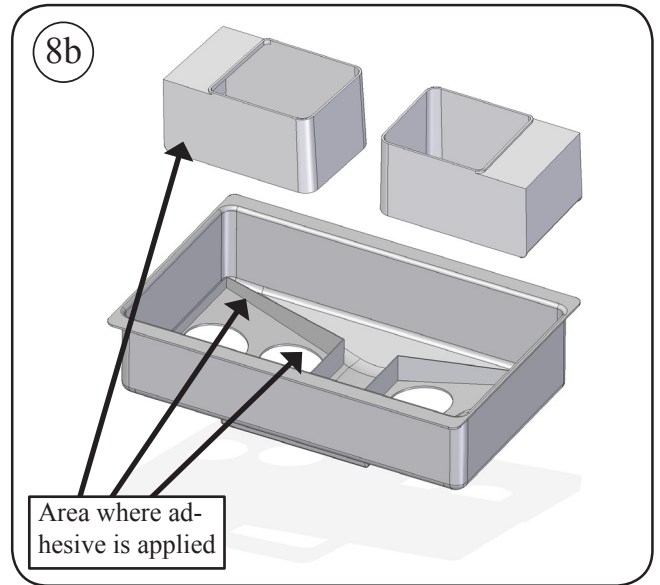

8c Connect the (2) 4-way boxes and (1) 2-way box of the interior air distribution panel to those of the **Bycool**.

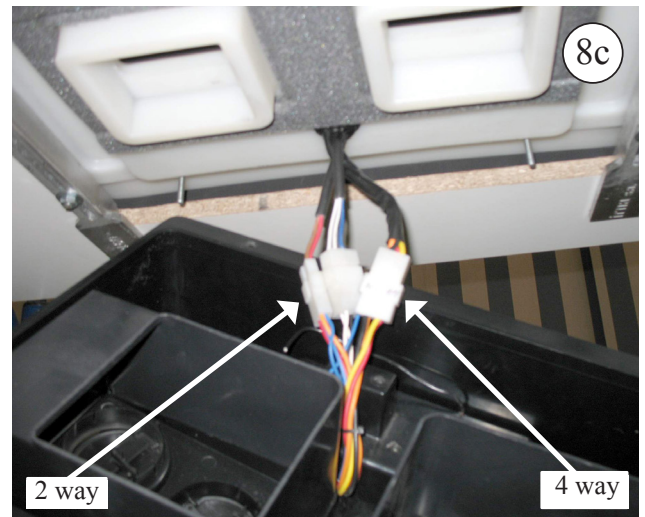

9 Position the interior air distribution panel on the front studs with (1) M6 wide-rimmed washer and (1) M6 nut on each stud. Tighten the nuts until the ducts come up against the unit's upper foam.

Important: The channellers must meet the rubber to avoid air leaks.

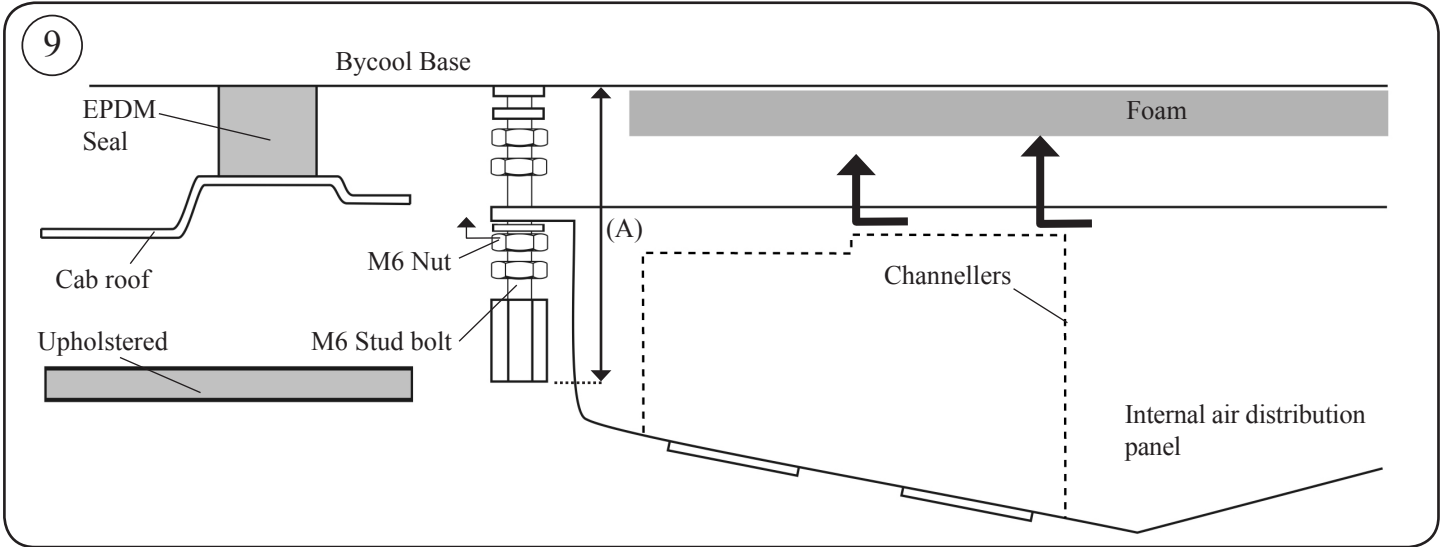

10 Tighten the nut in point 6a until it comes up against the top part of the interior air distribution panel.

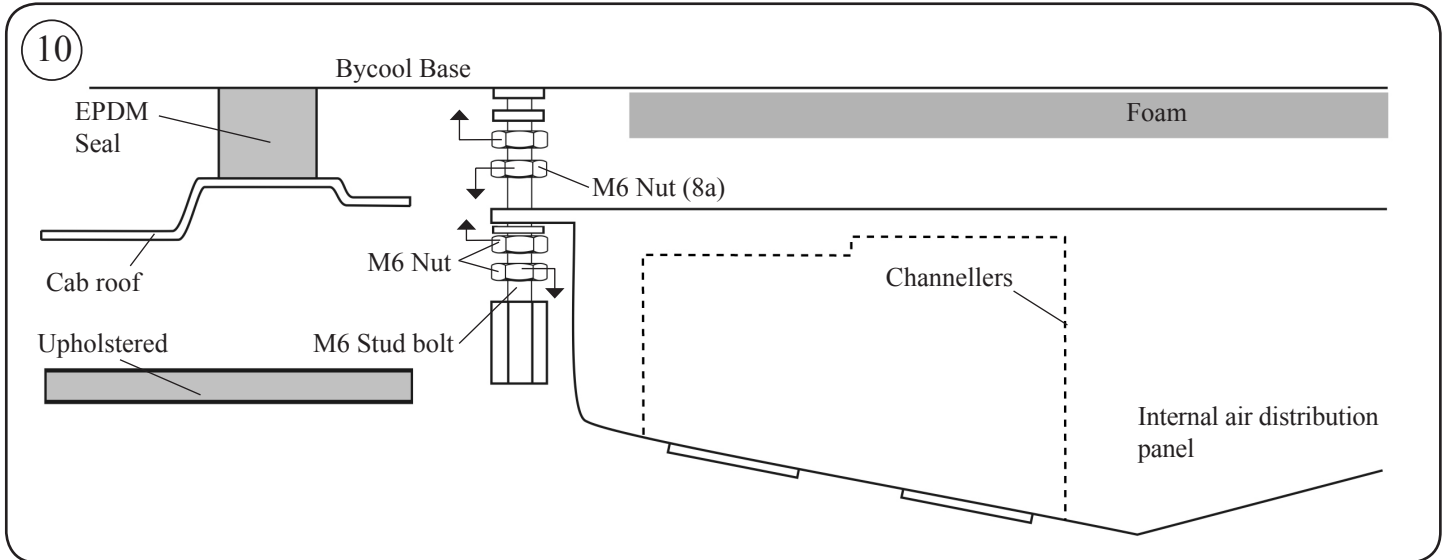

11 Place the console and centre the equipment on the most suitable place on the cab roof. Once centred remove the console.

12 Fasten the fastening supports by tightening the nut until the outer EPDM seal tightening of the equipment is between 3 and 6mm.

Important: To avoid possible water leaks into the inside of the cab the EPDM seal tightening must be adjusted with the base of the Bycool as indicated in the **drawing**.

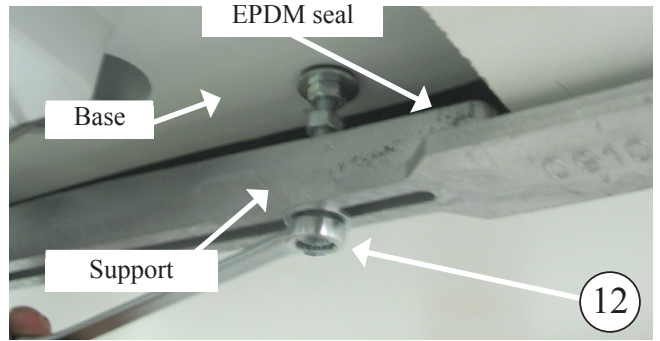
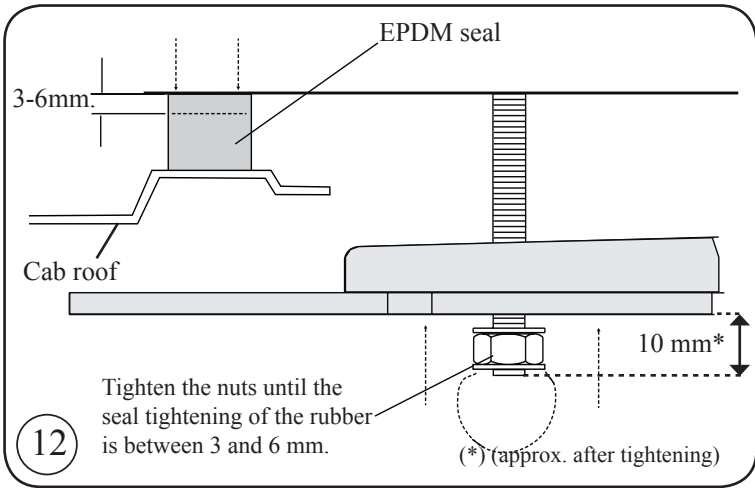
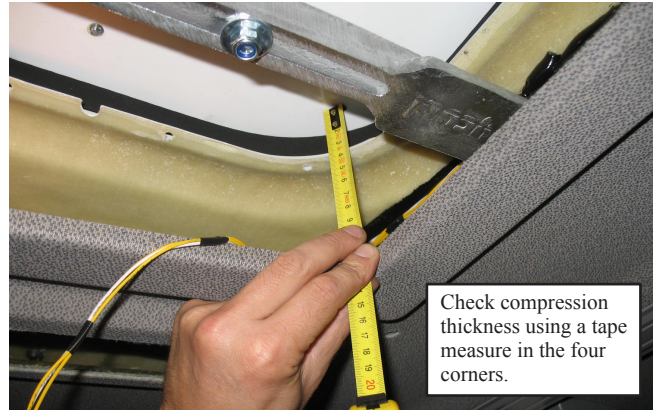

13 Screw (4) M8 nuts to the support and (4) to the base of the Bycool.

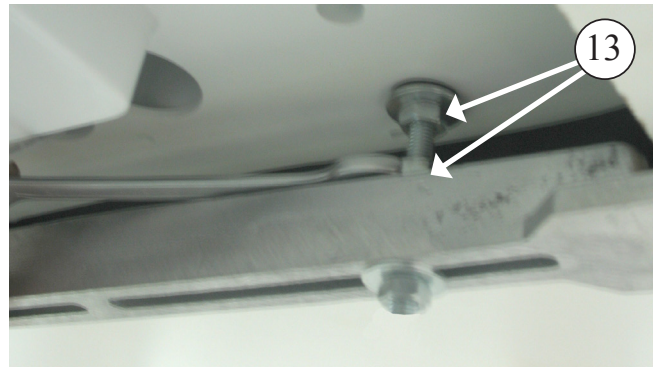

14 Position nut M6 (A) after the fastening nut of the interior air distribution panel on each stud. Screw on M6 hexagons up to 1 mm above the upholstery. Unscrew the M6 (A) nuts of this point until they come into contact with the hexagons, and tighten against them.

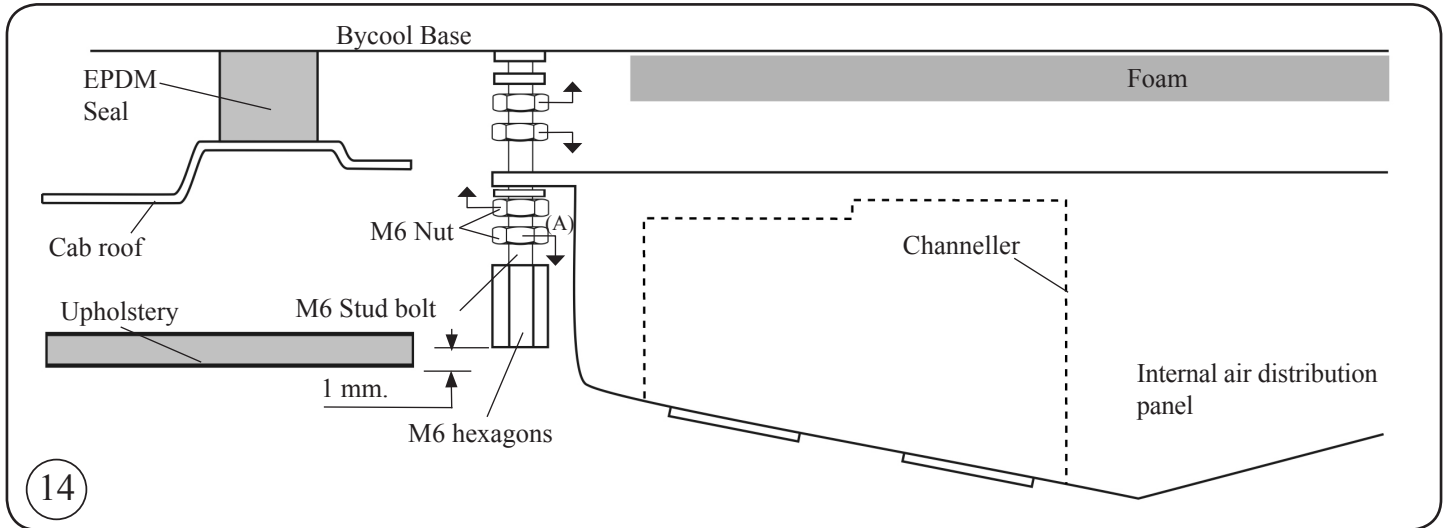
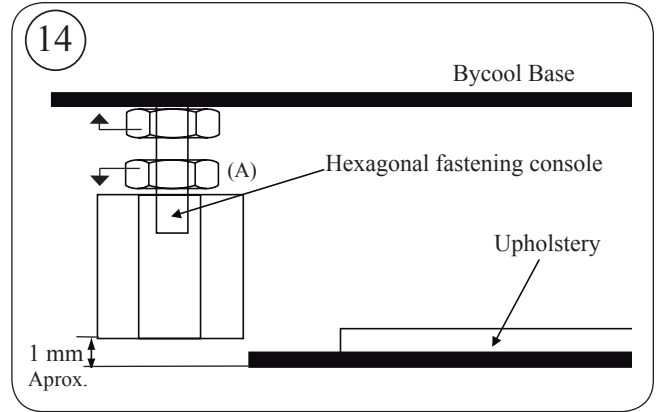

15 Fix the console with (4) Allen screws M6/100x15.

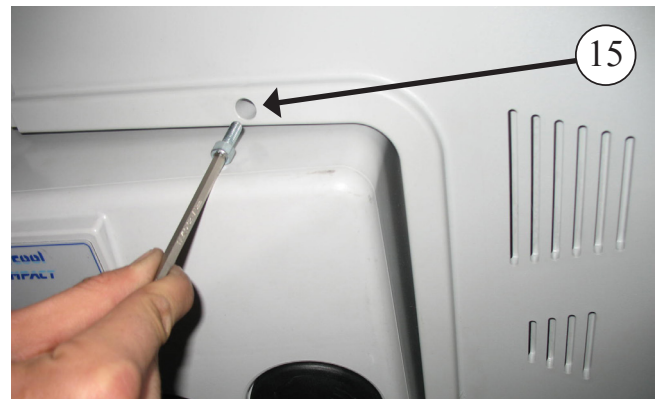

15a Cover the (4) M6/100x15 Allen screws with the round M6 plastic screw covers.

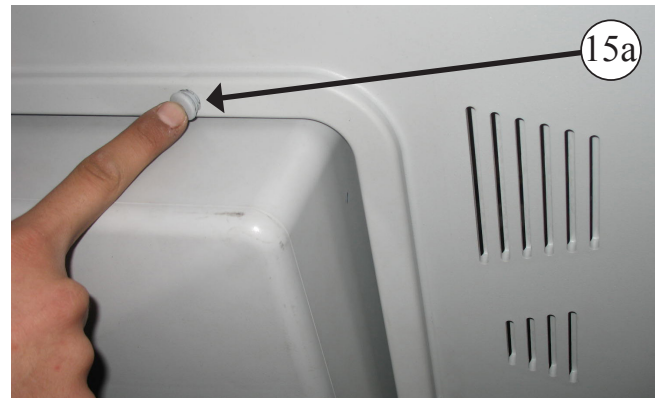

Exploded view to support fastening

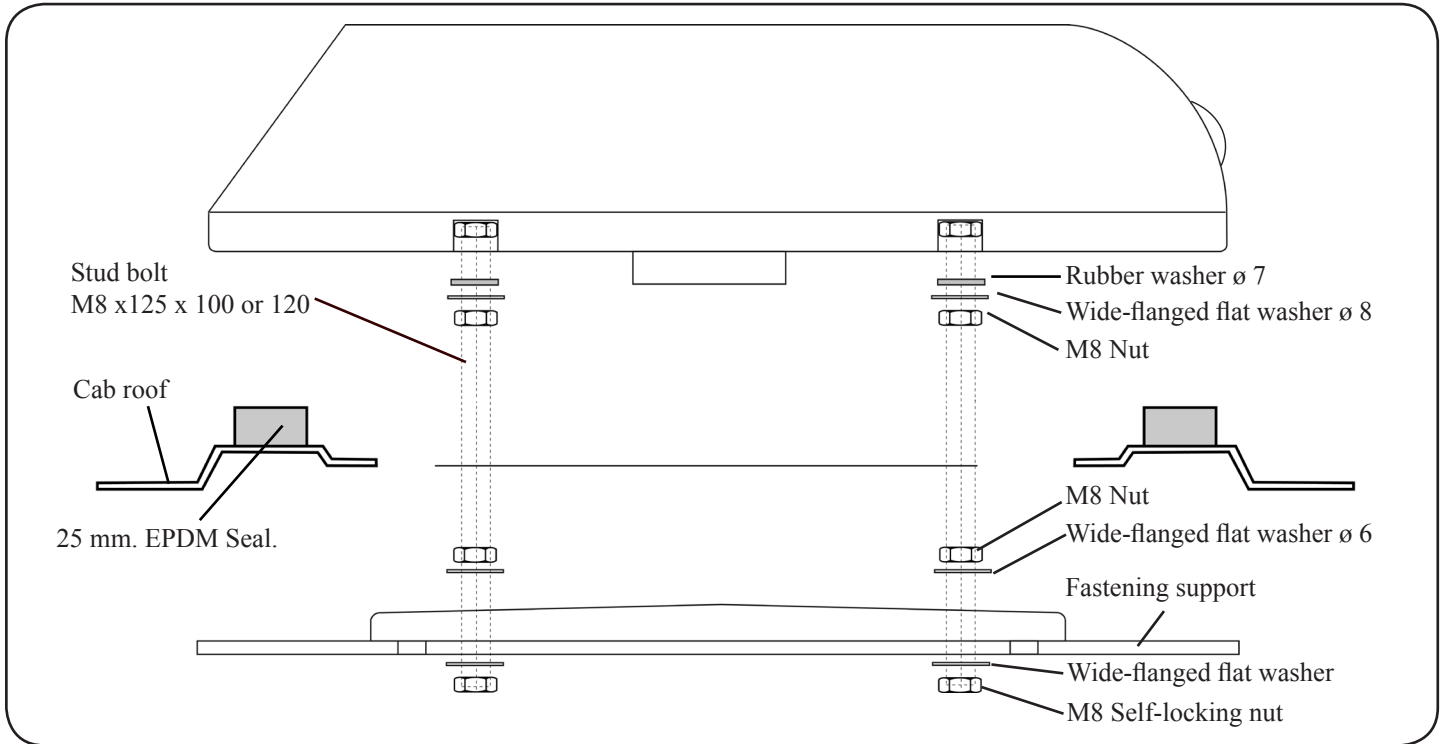

Exploded view to the console fastening

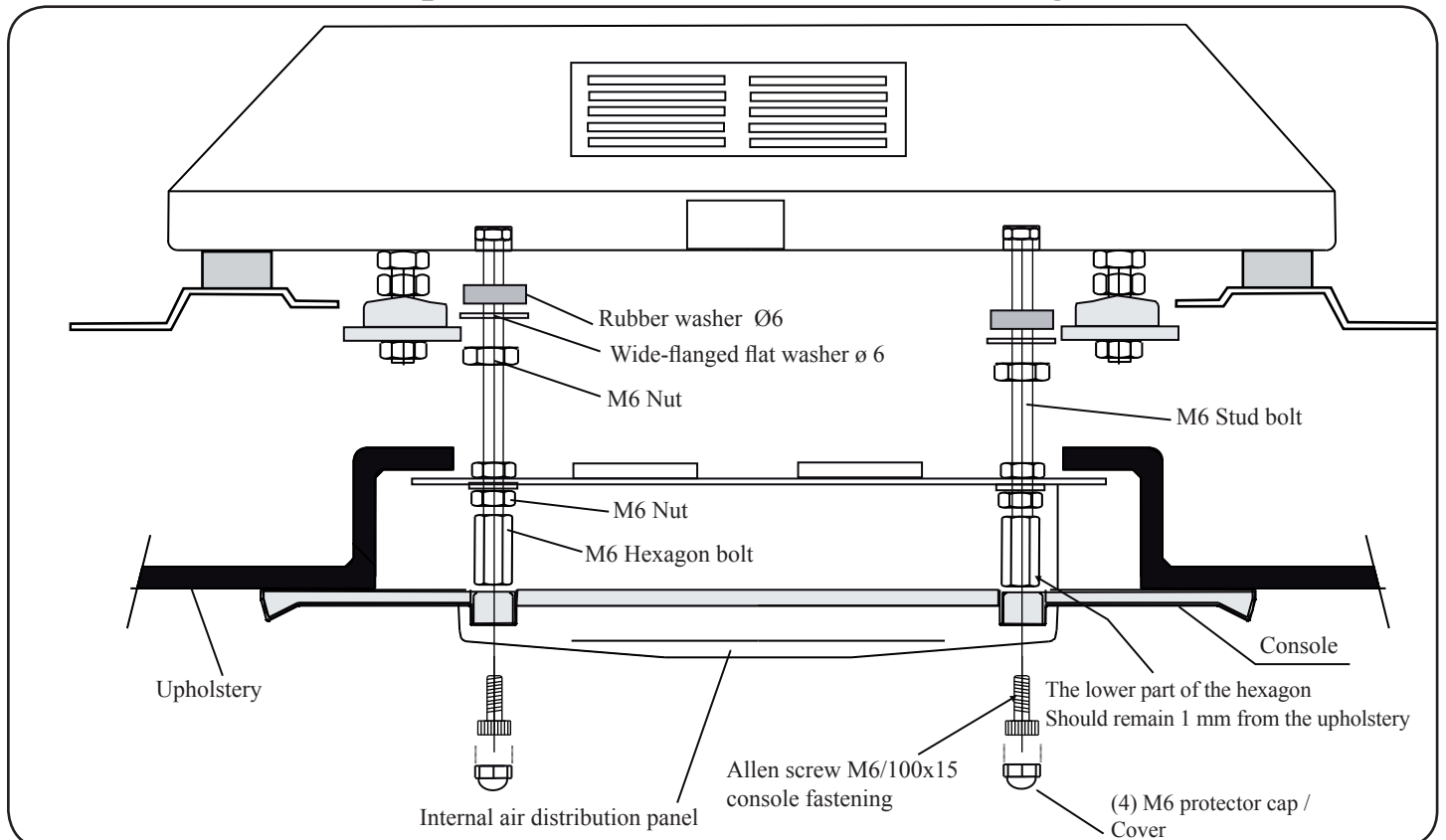

16 Connect cabling boxes and pipes, through the rear part of the Bycool as indicated.

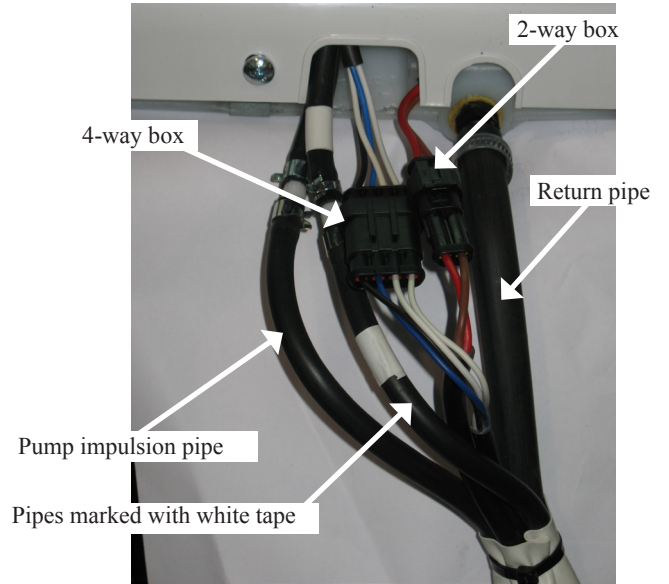

17 Place tank support on the most suitable lower part of the rear area of the cab. Mark and drill Ø 9 on the cab bearing in mind the vertical position of the support. Minimum (6) fastening drill holes.



18 Place M6 rivet nuts and fix the support with M6/100x30 screws. (*) – Where it does not lean on the even part, place a 10mm separator and screw M6/100 x 40.

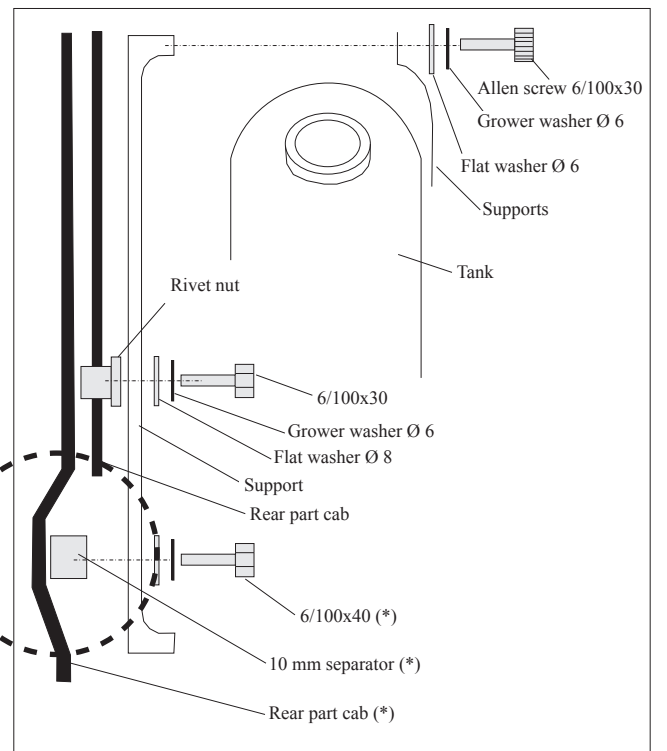

19 Fasten the tank pump unit with (2) sheet metal screws 5.4x19 mm.



20 Then connect the pump pipe (x) to the tank and fasten tank (*choosing the best position for the filling plug, right or left, to enable this*) with supports supplied. The support with the projection is placed, if the tank is assembled with the filling plug, (Y) to the left-hand side.

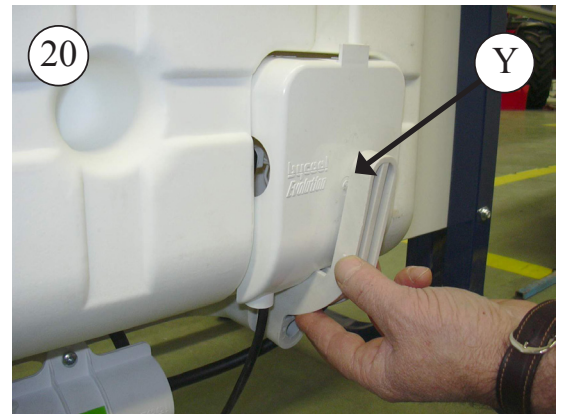
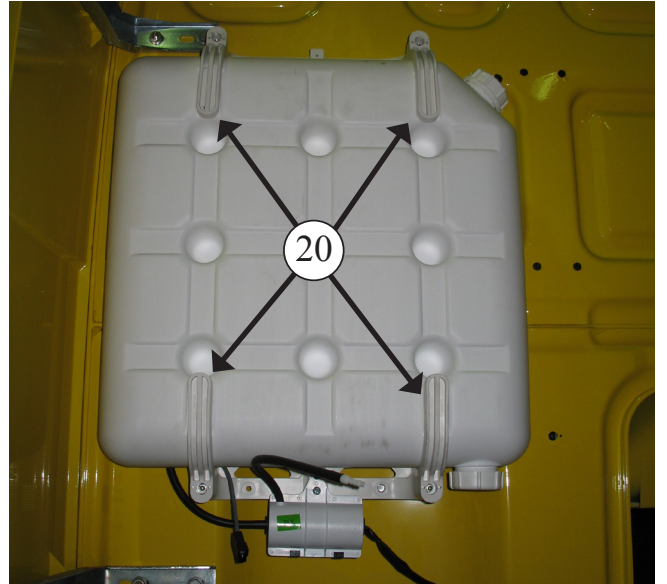

21 Assemble the filter in the pipe with a bolt, insert into the filler plug and connect to the return pipe Ø18 x Ø12 (A).

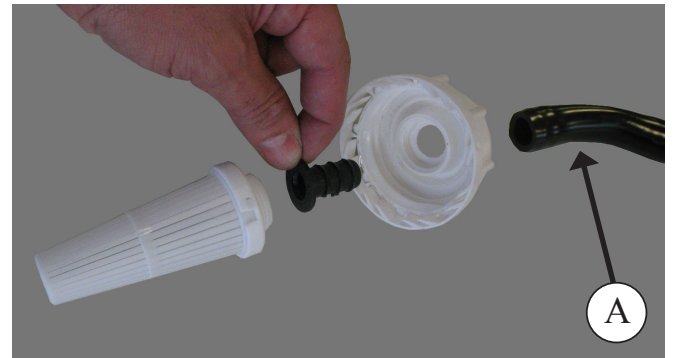

22 Place the filler plug in the tank, cut to 100mm; insert "T" and connect the pipe with the smaller diameter to this, **mark with white tape and check that the curve radius is big enough to avoid constriction.**



23 Connect sheathed wiring to the evaporative boxes and water inlet pipe.

- A. Connect the impulsion pipe to the pump which comes from the evaporative unit.
- B. Connect pump wiring and level.

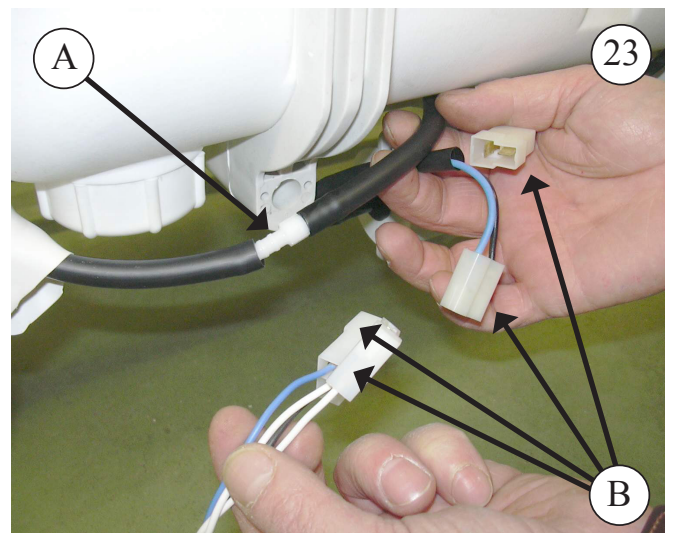

24 Connect the battery wiring as indicated.





25 **Drain pipe**

(*) Correct installation method, where the drain pipe has a slope avoiding loops and constrictions, enabling the water to drain into the tank.

(**) Incorrect method. Do not do this.

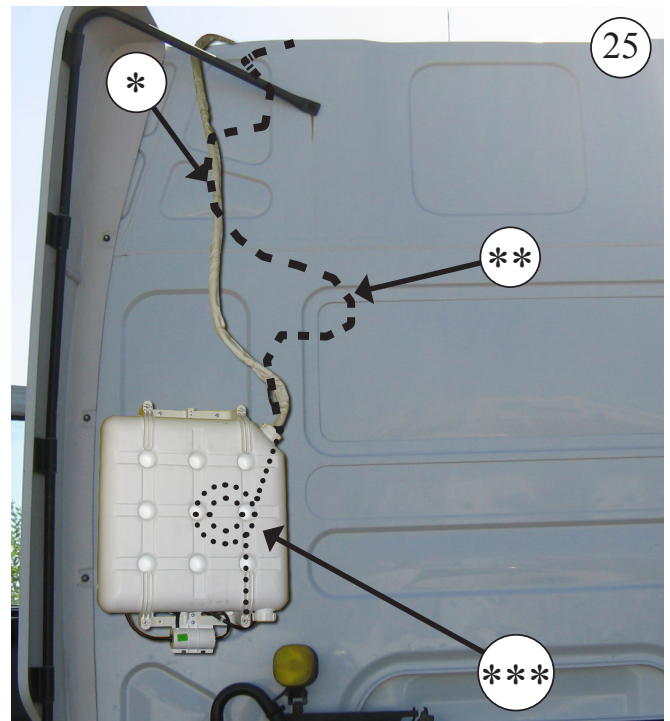
(***) DO NOT CUT surplus cable and attach it (wound), behind the water tank.



 **Important:**

The evaporative air conditioner works by taking air which is brought into the cab from the outside. The air must not become stagnant inside, as this would produce excessive humidity. All modern vehicle cabs are fitted with air vents, so air is able to leave if needed. For example, for the heating.

The installer must check that vents are in place, and if not, they must be installed.

The user must also regularly check that these vents are not clogged.

Detailed instructions about power supply installation



1- Run the power cable of the equipment to the vehicle battery, sticking the plastic supports on the rear part of the cab and attaching it with cable ties; then with the cab folded forward pass the cable through the lower area and fasten it with clamps and M4 screws; and as far as the battery with cable ties; the same pitch should be used as that of the original cable. *(Clean the area well before sticking the plastic supports).* On connecting the equipment to the battery this will automatically carry out a test on all its leds, and will switch off.

IMPORTANT: Due to the complex system of electronic regulation of the equipment, the current connection must be made directly to the vehicle battery, and not to any other point which services other accessories of the vehicle, taking the precaution to not invert the polarity when making the connection (2). Inverting polarity may result in irreparable damage to the electronics, which is not covered by the warranty.

IMPORTANT: To start the machine consult the User Manual.

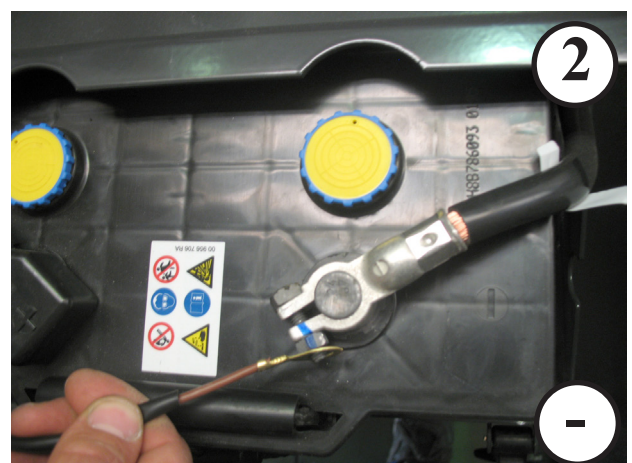

Wire diagram

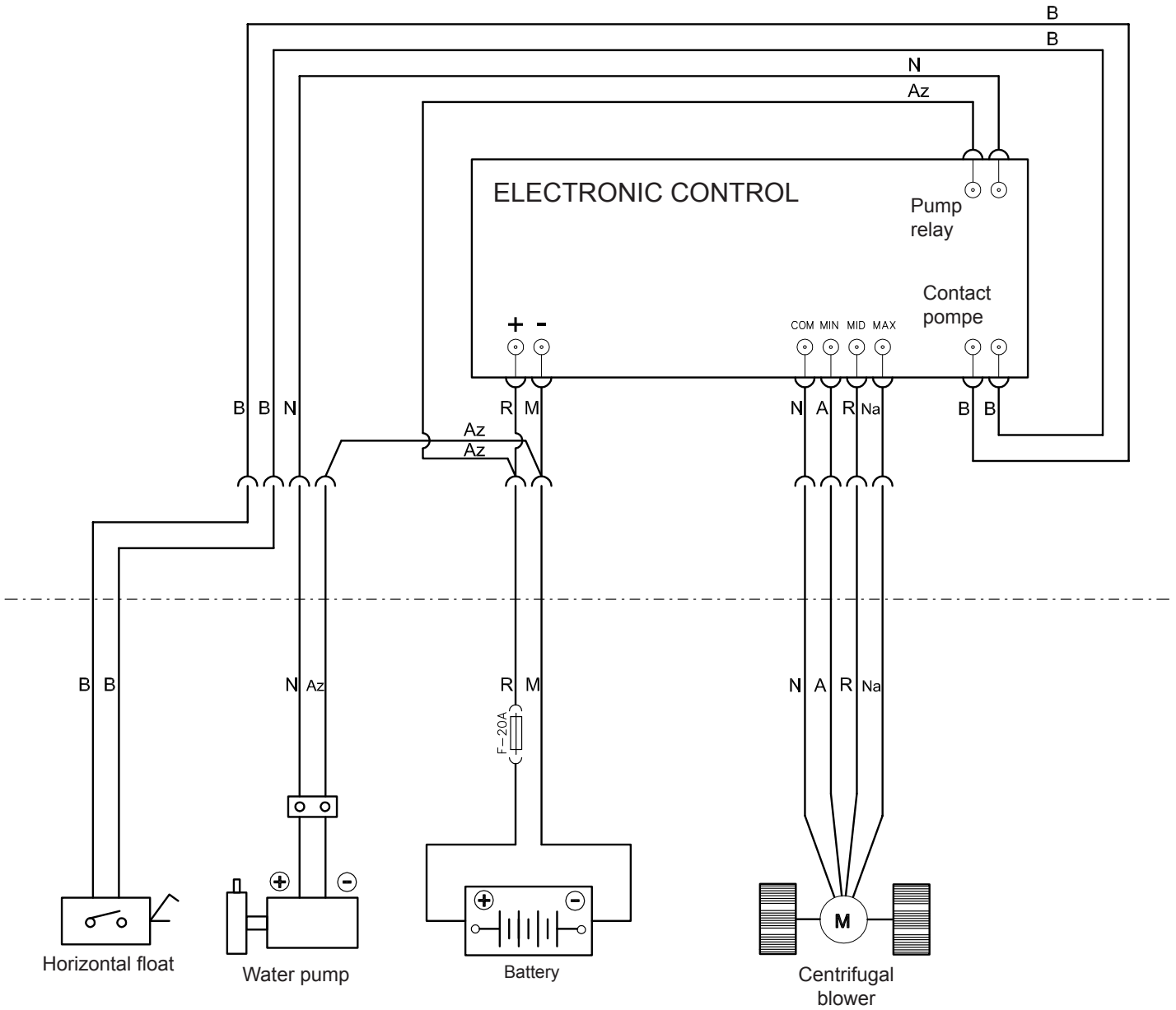

WATER PUMP FLOAT

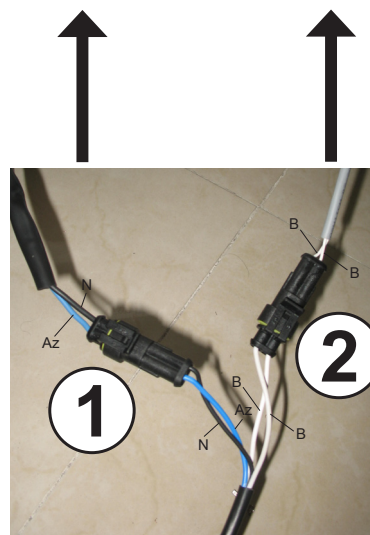

COLOURS

A	Yellow
Az	Blue
B	White
G	Grey
Na	Orange
N	Black
R	Red
Ro	Pink
V	Green
Vi	Violet
M	Brown
Mo	Purple

RECOMMANDATIONS POUR LE MONTAGE

- Lire les instructions avant de commencer le montage, et les suivre pendant tout le procédé d'installation.
- Utiliser des outils adaptés à chaque opération.

ÉLECTRICITÉ

- Déconnecter la clé de contact.
- Déconnecter la batterie avant de commencer le montage.
- Assurer le raccordement des composants électriques en vérifiant que l'emboîtement est correct.

Outils

Jeu de Clés Torx
Jeu de Clés Allen
Clé fixe 10, 13, 14
Ciseaux
Flexomètre

DOCUMENTATION FOURNIE AVEC L'ÉQUIPEMENT:

- Instructions de Montage: 220.AA7.0001
- Manuel de l'Usager: 220.AA7.0003
- Diagnostic de Pannes: 220.AA7.0004
- Garantie: 220.AA1.0010

ATTENTION :

Lorsque l'équipement évaporatif est installé sur le plafond, il faut protéger la partie supérieure de la cabine avec un chiffon ou un tissu protecteur pour éviter les éraflures. Lorsque le Bycool Flat est fixé au plafond, il faut savoir que, normalement, les cabines qui sont munies d'une écoutille possèdent une structure suffisante pour supporter le poids de l'équipement. Cependant, si ce n'est pas le cas, et s'il est nécessaire d'effectuer une coupure dans le plafond et le matériel n'est pas assez résistant, même s'il incorpore une écoutille (plafond en fibre, plastique, etc.), l'installateur devra décider, sous sa responsabilité, le besoin ou pas de renforcer le plafond pour éviter de possibles déformations, cassures, entrées d'eau, etc., en utilisant les moyens nécessaires pour que cela ne se produise pas.

AVERTISSEMENTS :

- La pièce n° 17 de la liste des Pièces Fournies doit être remplacée tous les 12 mois.
- **dirna Bergstrom, s.l.** est exempte de toute responsabilité en cas de pannes dues à une manipulation ou à une installation incorrectes de l'équipement, ou bien à cause de modifications ou de remplacements réalisés sans notre autorisation expresse par écrit.
- Voir **procédé de garantie** du produit inclus dans **Diagnostic de Pannes**.
- Voir **Manuel de l'Usager** de l'équipement pour le fonctionnement correct de la télécommande et du panneau de contrôle.

1 Démontez le couvercle écoutille, les éléments de fixation et les remettre au client (*).



1a Dans le cas où il n'y a pas d'écoutille, découper le toit selon les dimensions minimums indiquées.

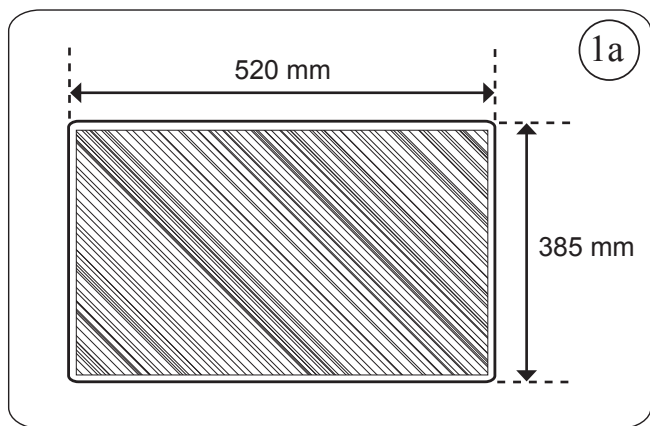

Dimensions min. de découpage du toit de la cabine s'il n'y a pas d'écoutille

2 Enlever les résidus restants adhérents au toit avant de coller le joint EPDM.

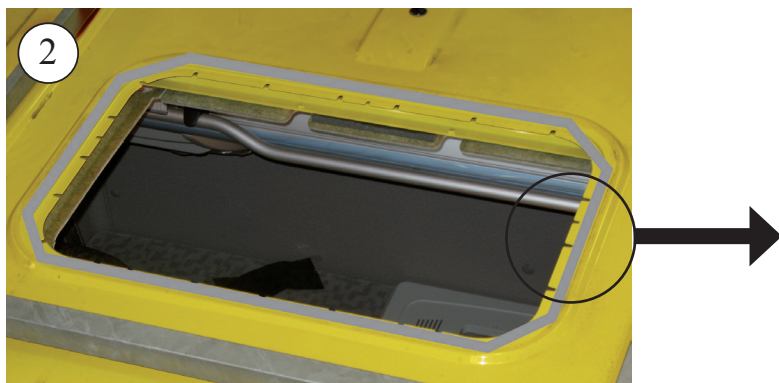

3

Collez le joint EPDM autour du creux de l'écouille (*regarder le détail pour couper les bords d'union du joint*)

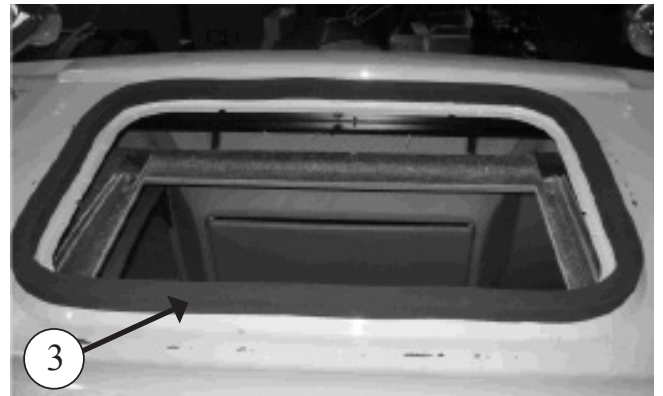

COMMENT COUPER LE JOINT EPDM POUR ÉVITER LA FILTRATION DE L'EAU DANS LA CABINE

A- Coller le joint, tout en maintenant 100 mm de papier protecteur de chaque côté.

B- Enlever les deux pièces en papier.

C- Coller en faisant pression sur les deux bouts.

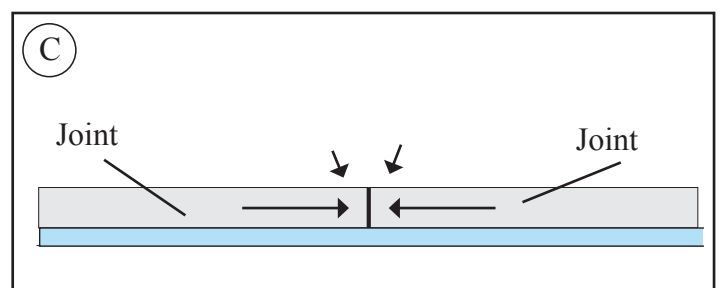
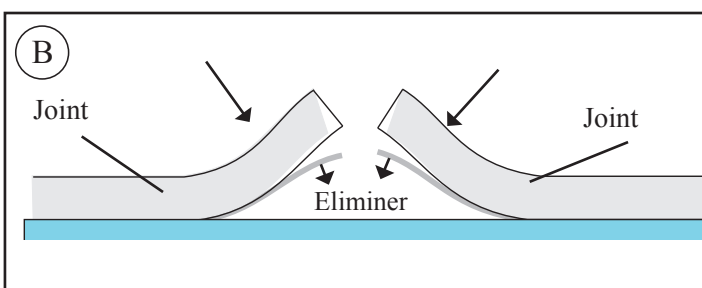
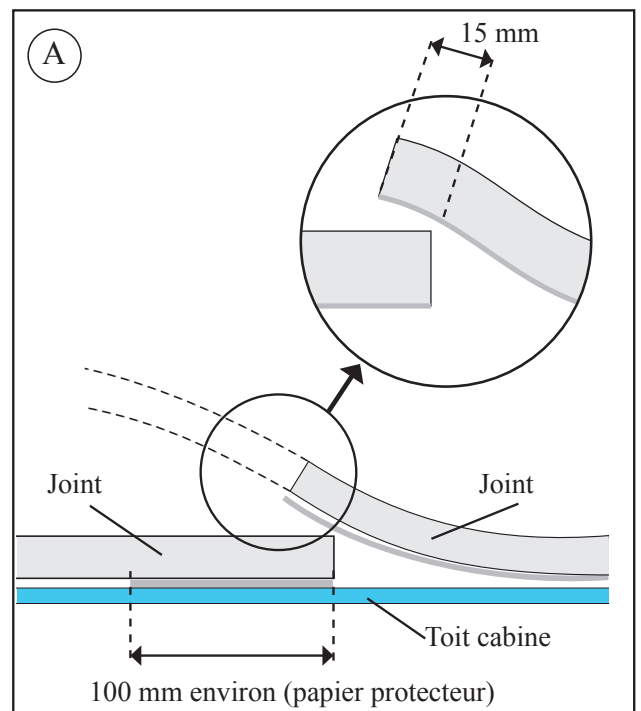

4 **EXTERIEUR CABINE:**
Placer le Bycool dans le creux de l'écouille.

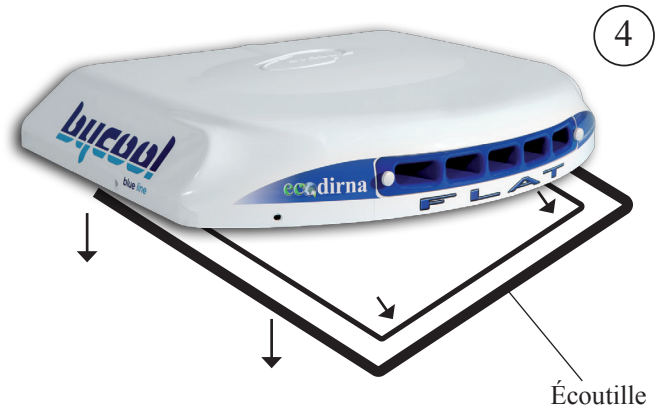

5 **INTERIEUR CABINE:**
Visser (4) perches 8/125x100 ou 120 environ 5 mm, la mesure sera choisie après présenter les supports de fixation et en tenant compte que les perches doivent ressortir environ 10 mm de ceux-ci par la partie inférieure.

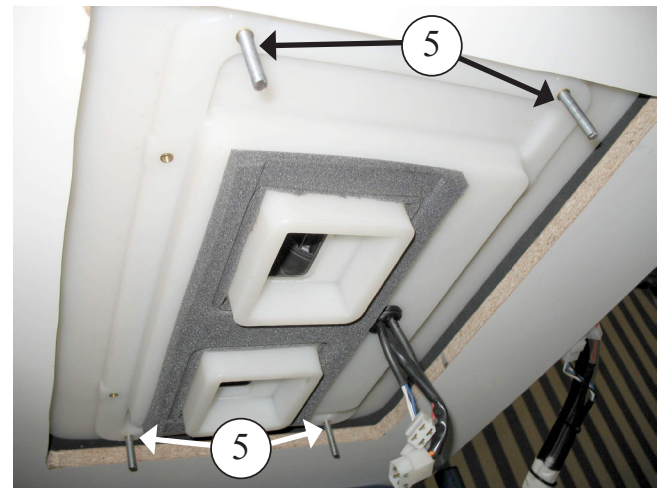
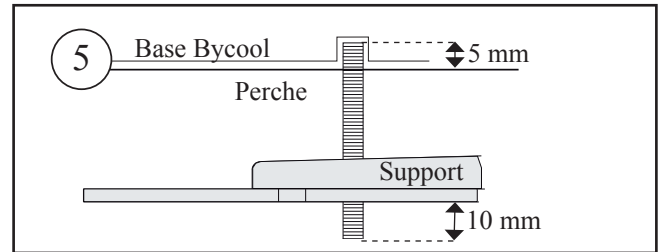

6 Placer (1) rondelle Ø 7 en caoutchouc, (1) rondelle plate Ø 8 surface large, (2) écrou M8 et (1) rondelle plate Ø 8 surface large, sur chacune des perches précédentes.

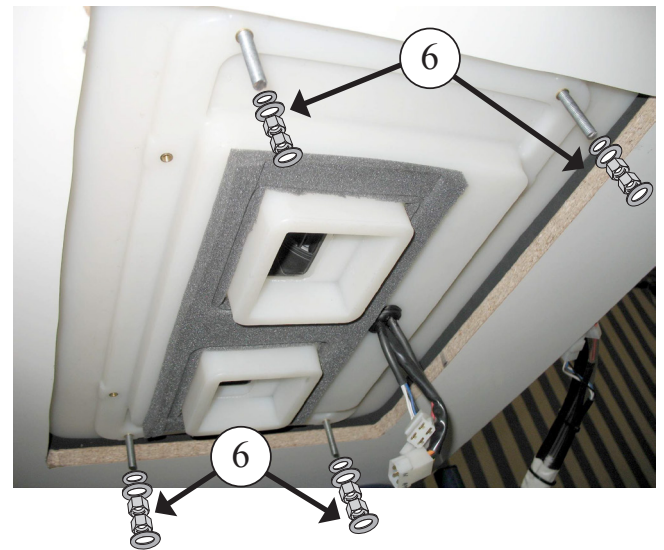

6a

Placer (2) supports de fixation, avec (1) rondelle et (1) écrou autobloquant M8, **sans serrer**.



7

Visser (4) perches M6 x 55 ou 80 10 mm, à l'endroit indiqué, selon la hauteur (A) sur le schéma du point 9.

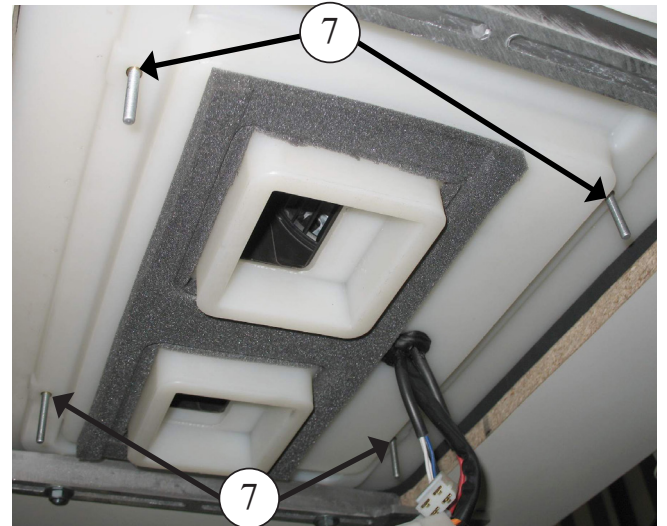

8

Placer (1) rondelle Ø6 en caoutchouc, (1) rondelle plate Ø6 surface large et (1) écrou M6, sur chacune des perches de M6. **Serrer l'écrou.**

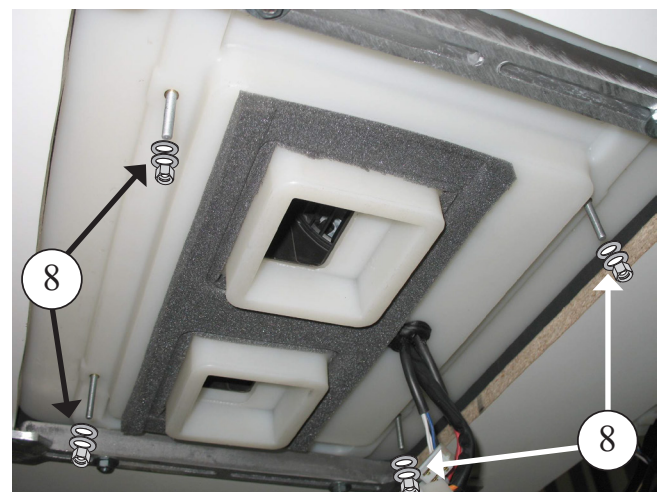

8a

Placer (1) écrou M6 **sans serrer** sur chaque perche.

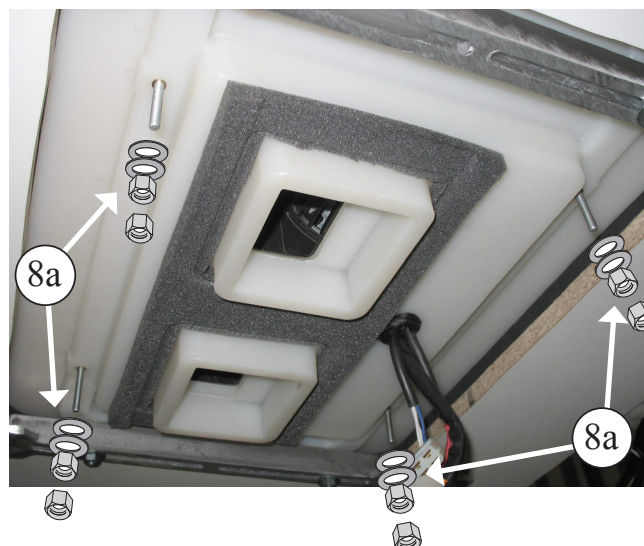
**8b**

Coller les canalisateurs sur le panneau intérieur de distribution en utilisant du LOCTITE superglue 3 ou similaire, afin de faciliter le montage de l'ensemble et assurer les flux d'air froid par les fenêtres.

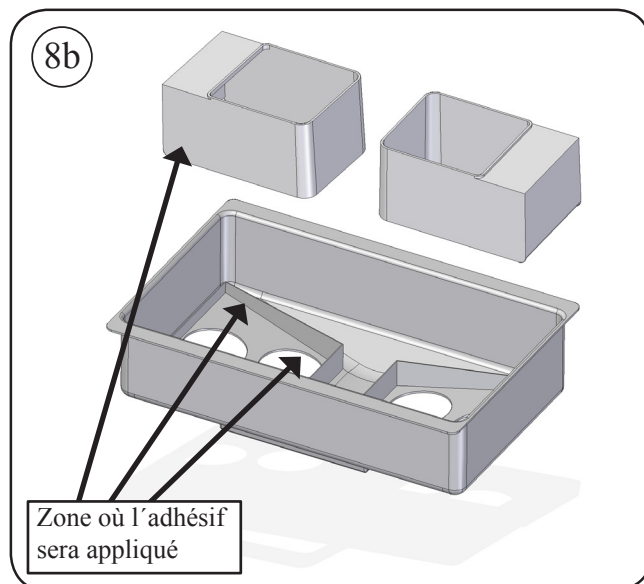
**8c**

Connecter les (2) boîtes à 4 voies et (1) à 2 voies du panneau intérieur de distribution d'air à celles du **Bycool**.

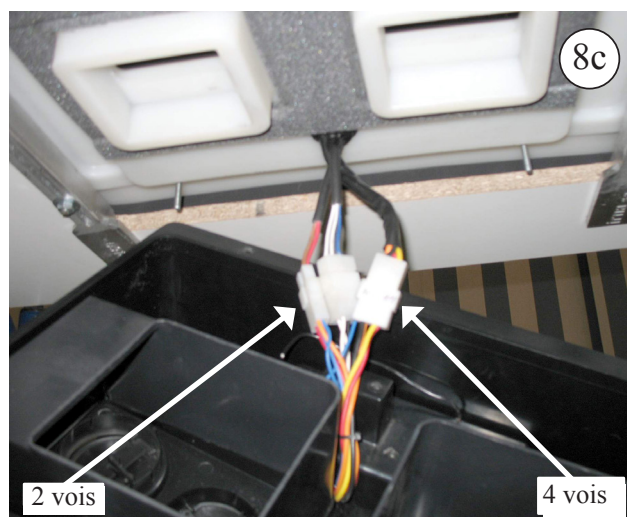

9 Placer le panneau intérieur de distribution d'air dans les goujons précédents avec (1) rondelle M6 surface large et (1) écrou M6 sur chaque goujon. Serrer les écrous jusqu'à ce que les canalisateurs heurtent le caoutchouc mousse supérieur de l'équipement.

Important: Les canalisateurs doivent toucher le caoutchouc mousse pour éviter les fuites d'air.

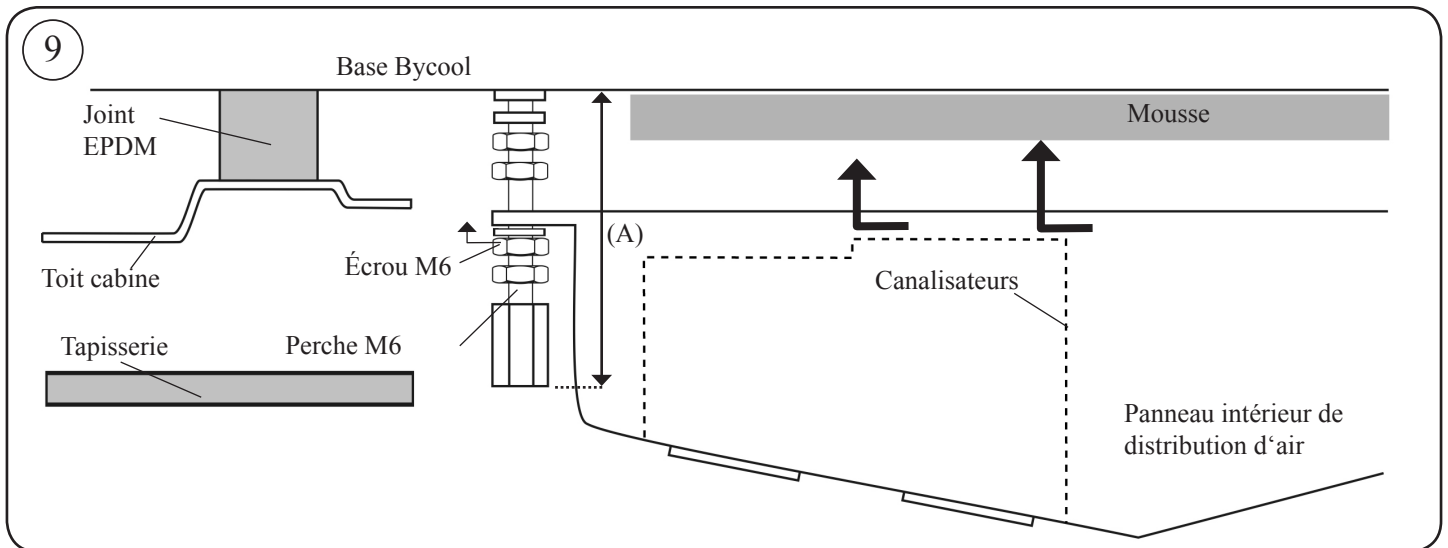

10 Serrer l'écrou du point 6a jusqu'à atteindre la partie supérieure du panneau intérieur de distribution d'air.

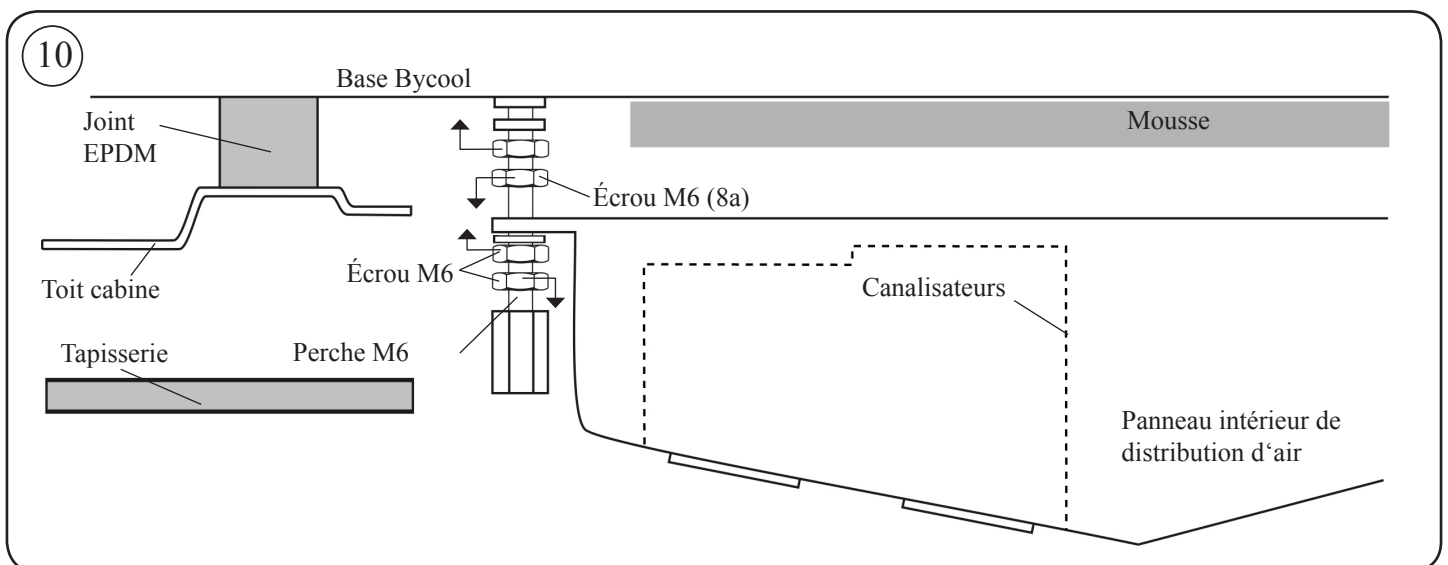

11 Présenter la console et centrer l'équipement à l'endroit le plus approprié du toit de la cabine. Une fois centré, retirer la console.

12

Fixer les supports de fixation en serrant les écrous jusqu'à serrer le joint de EPDM extérieur de l'équipement entre 3 et 6mm.

Important: Pour éviter de possibles filtrations d'eau à l'intérieur de la cabine, vous devez assurer la fixation du joint EPDM avec la base du Bycool comme il est indiqué sur le **schéma**.

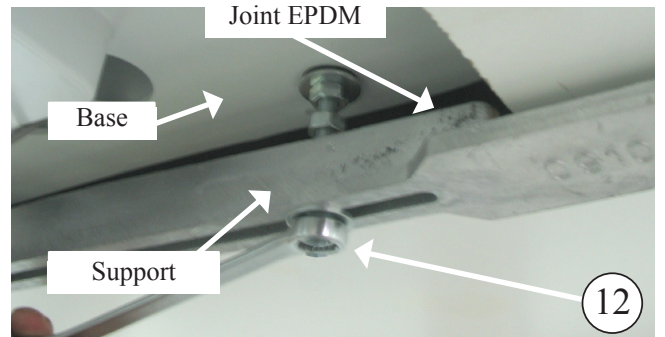
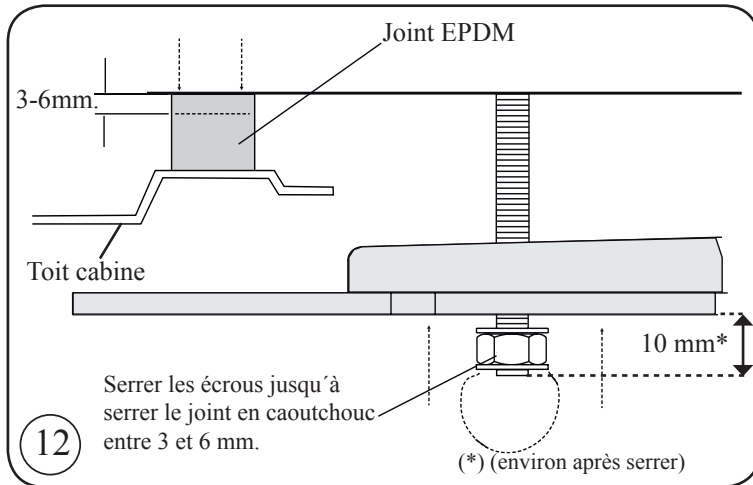
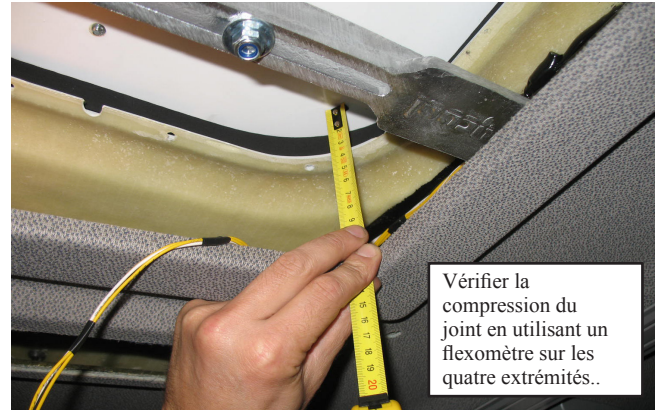

13

Serrer (4) écrous M8 au support et (4) à la base du Bycool.

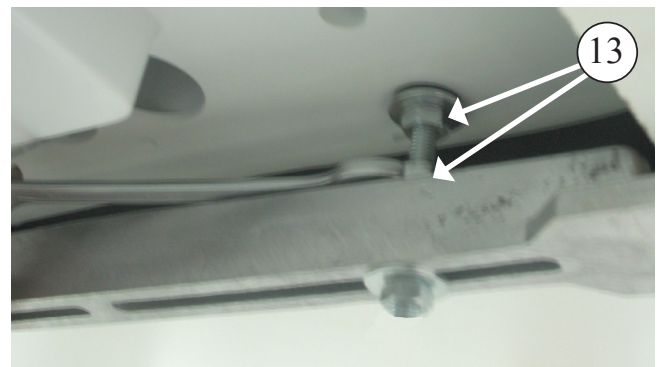

14

Placer un écrou M6 (A) après l'écrou de fixation du panneau intérieur de distribution d'air dans chaque goujon. Placer les hexagones M6 en vissant jusqu'à ce qu'il reste 1 mm au-dessus de la tapissure. Dévisser les écrous M6 (A) de ce point jusqu'à atteindre les hexagones et serrer contre eux.

14

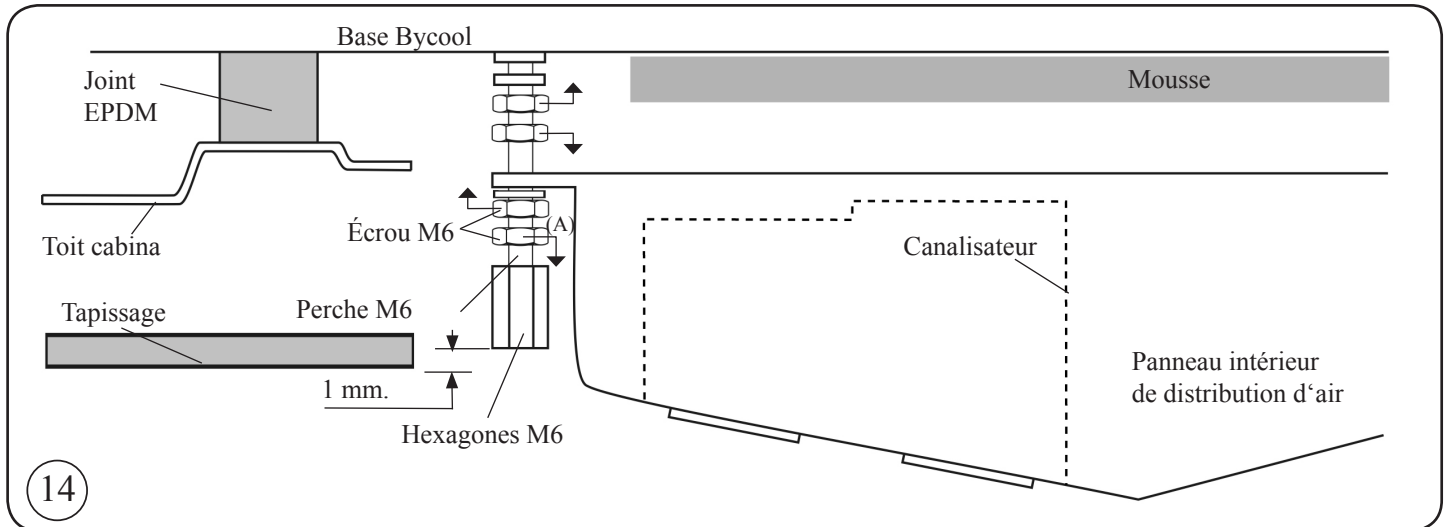
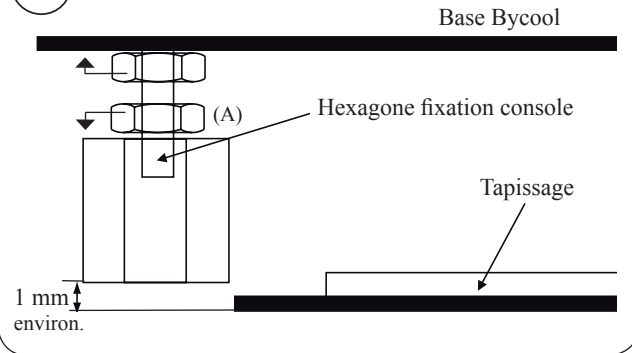

14

15

Placer la console avec (4) vis M6/100x15 allen.

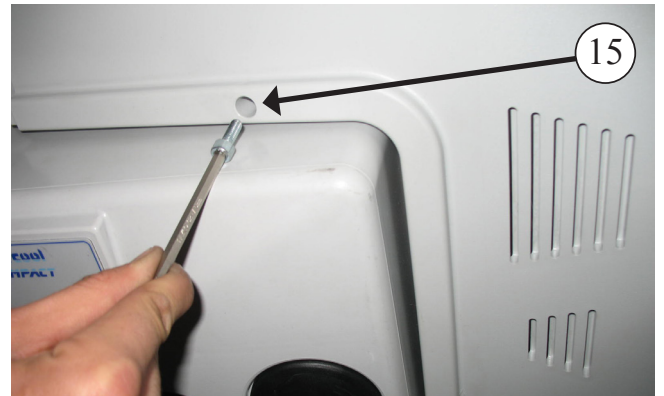

15a

Couvrir les (4) vis M6/100x15 allen avec les enjoliveurs ronds de M6 en plastique.

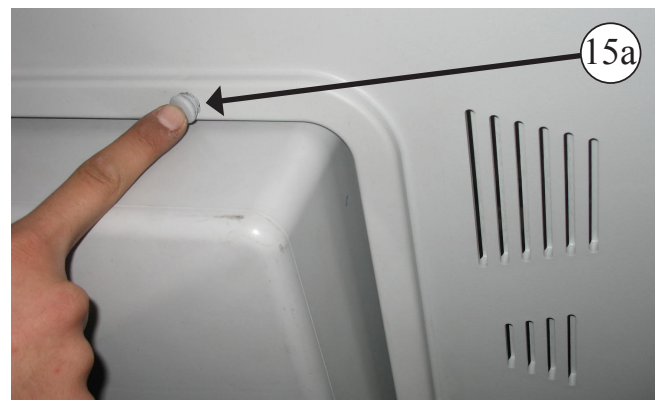

Vue agrandie jusqu'à fixation des supports

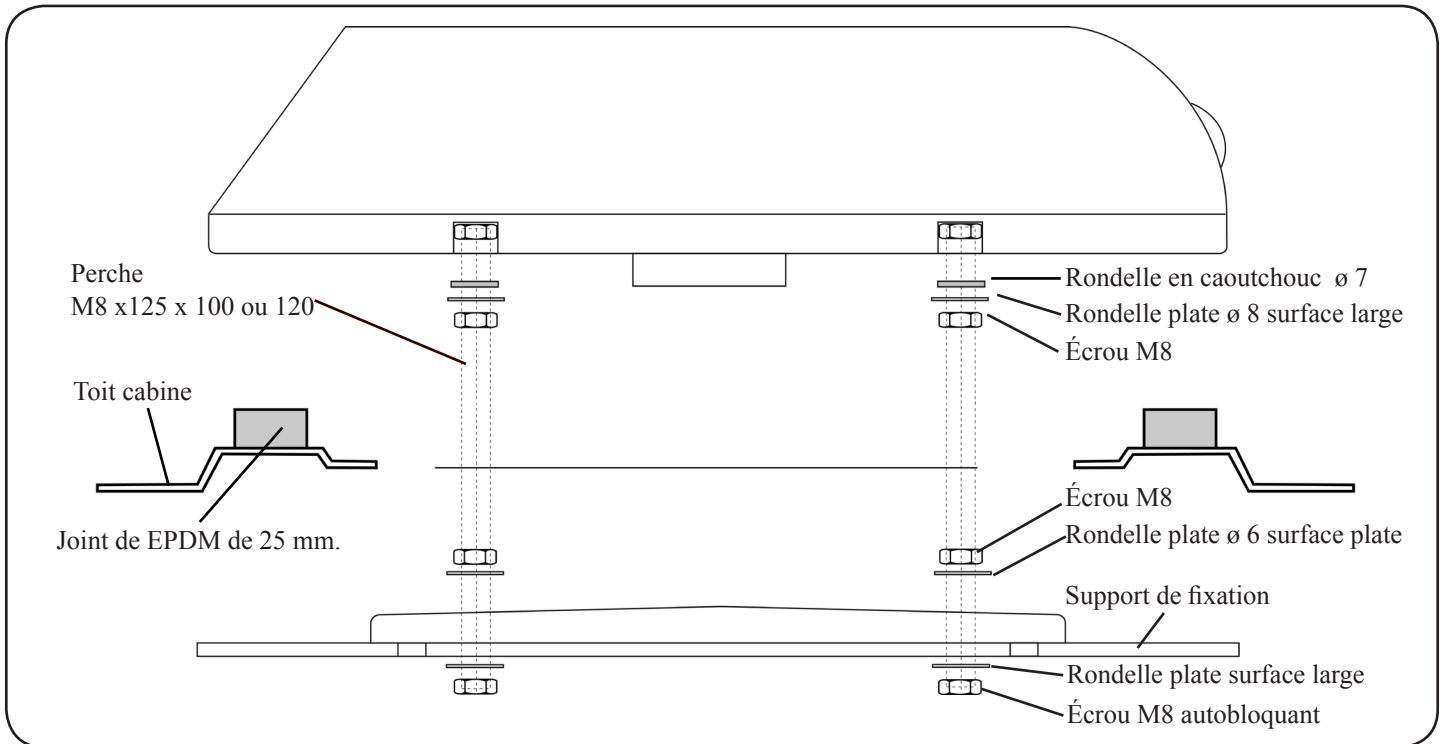

Vue agrandie jusqu'à fixation des consoles

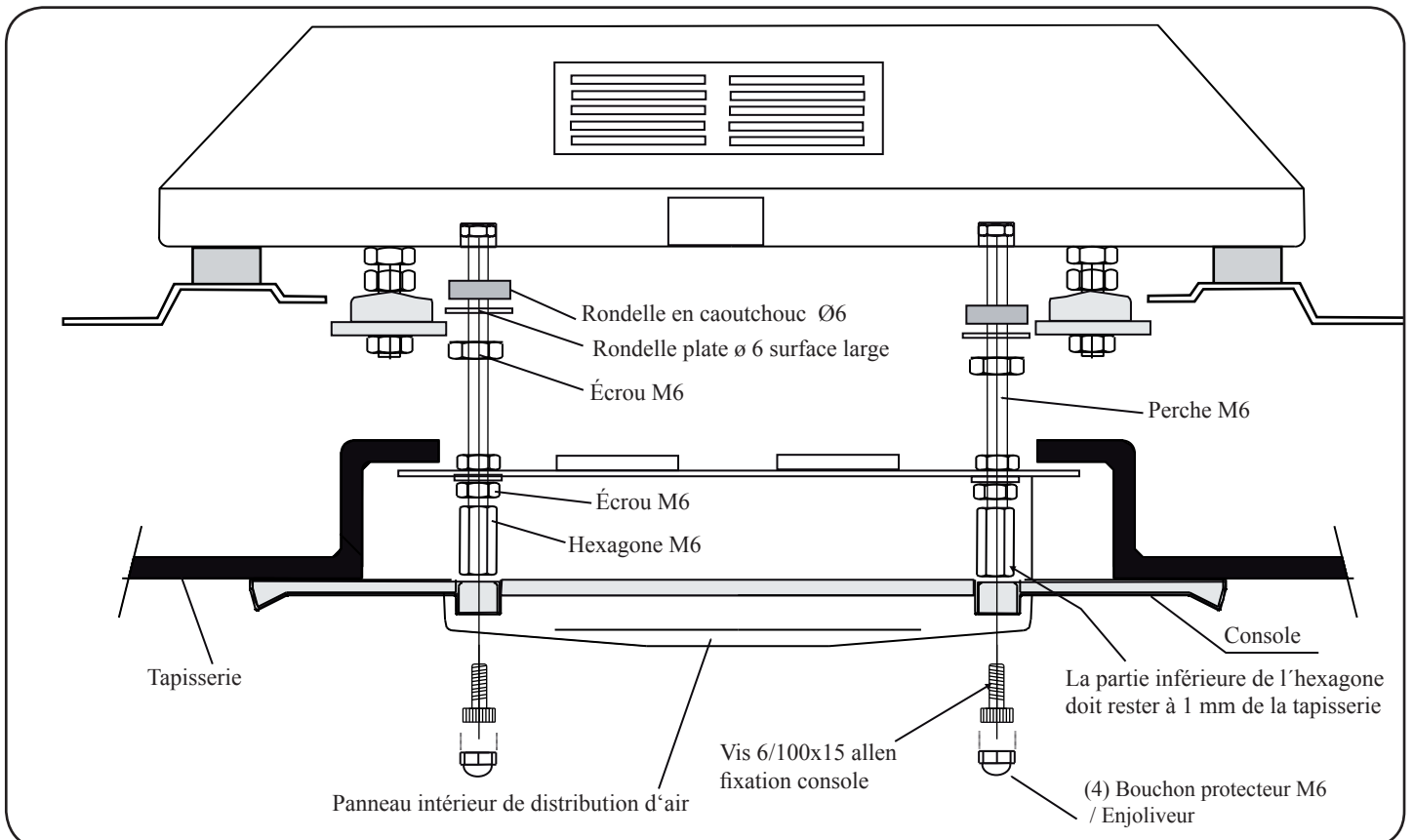

16

Connecter les boîtes de câblages et tuyaux par la partie arrière du Bycool, en suivant les indications.

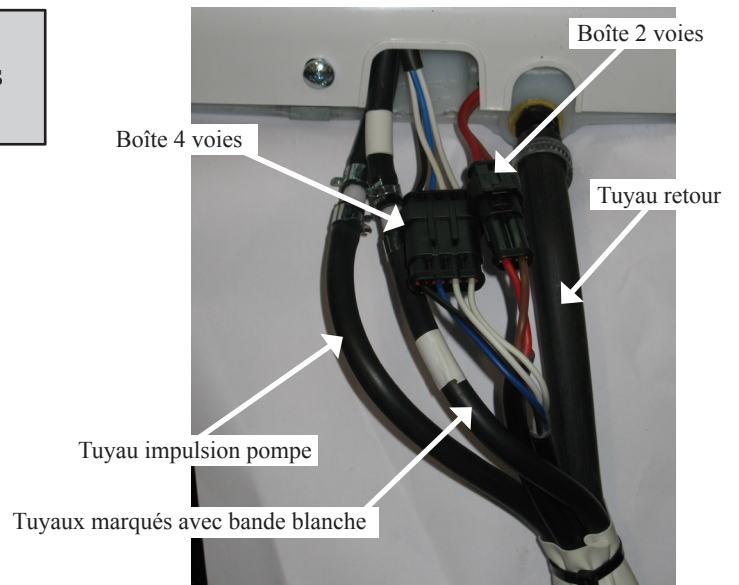

17

Placer le support réservoir dans la partie basse la plus convenable de la zone arrière de la cabine. Marquer et percer Ø 9 dans la cabine en tenant compte de la position verticale du support. Minimum (6) perçages de fixation.



18

Placer des écrous rivet de M6 et fixer le support avec des vis 6/100x30.
(*) – S'il n'y a pas d'appui sur la partie lisse, placer le séparateur de 10mm et la vis 6/100 x 40.

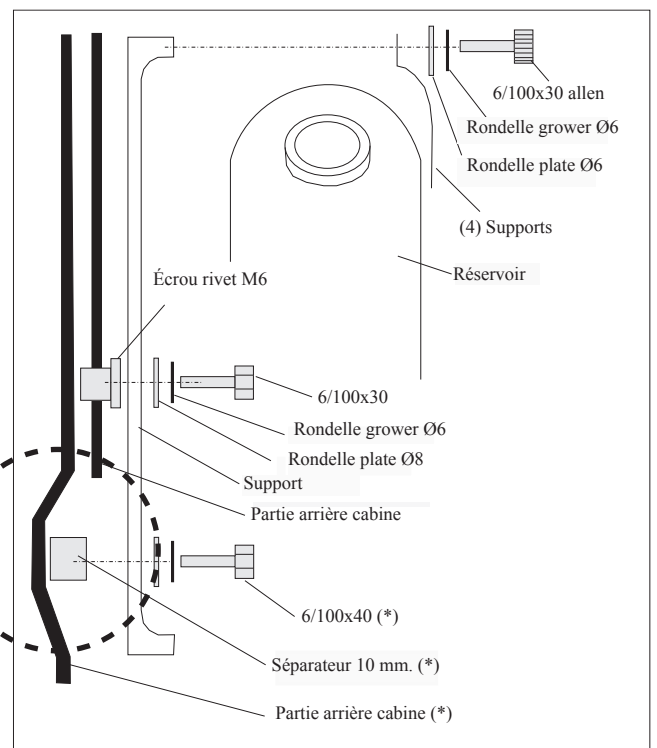

- 19** Fixer l'ensemble pompe au réservoir avec (2) vis filet plaque 5.4x19 mm.



- 20** Connecter ensuite le tuyau de pompe (X) au réservoir et fixer le dépôt (en choisissant la meilleure position du bouchon de remplissage, droite ou gauche, pour le faciliter) avec des supports fournis. Le support avec ressortant se place en cas de montage du réservoir avec le bouchon de remplissage (Y) sur le côté gauche.

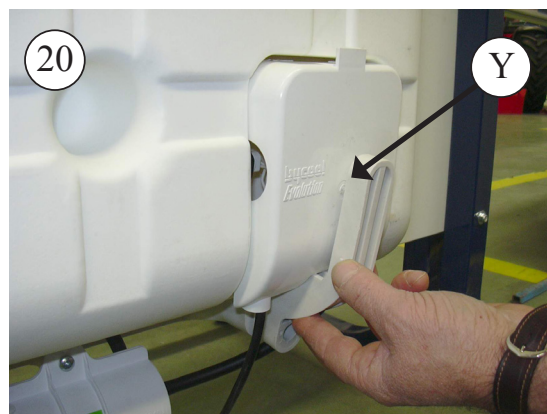
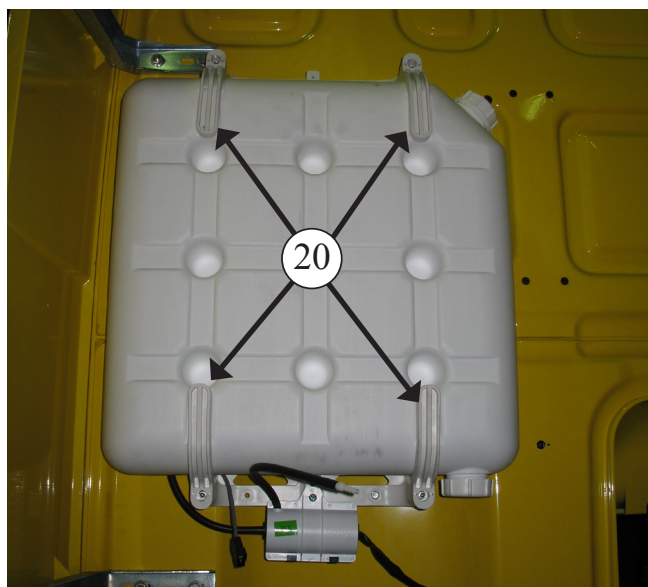

- 21** Monter filtre sur tuyau avec cheville, introduire dans le bouchon et connecter au tuyau de retour Ø18 x Ø12 (A).

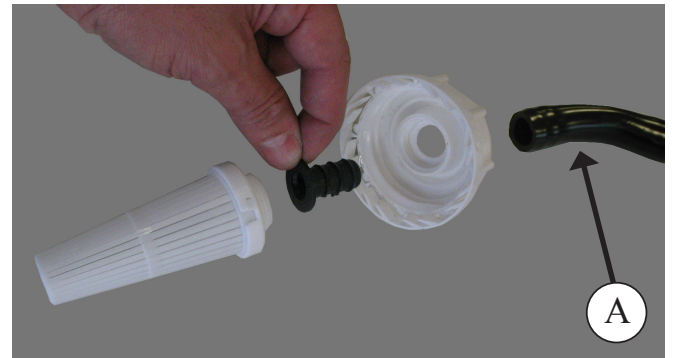

- 22** Placer le bouchon dans le réservoir, couper à 100 mm; intercaler "T" et connecter le tuyau avec la plus petite section à celle-ci, **marquer avec une bande blanche et s'assurer que le rayon de la courbe est suffisant pour éviter des étranglements.**



- 23** Connecter le câblage avec l'étui aux boîtes de l'évaporateur et au tuyau d'eau.

- A.** Connecter le tuyau d'impulsion qui vient de l'évaporateur à la pompe.
B. Connecter le câblage de la pompe et du niveau.

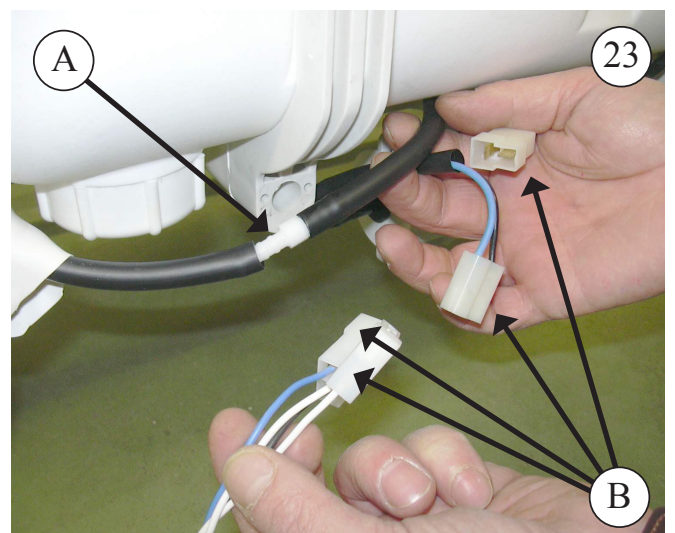

24

Connecter le câblage de batterie en suivant les indications.



25

Tuyau d'écoulement

(*) Installation correcte, qui permet que le tuyau d'écoulement ait une tombée tout en évitant les boucles et les étranglements, afin de faciliter la tombée de l'eau dans le réservoir.

(**) Installation incorrecte. Ne pas réaliser.

(***) NE PAS COUPER le câblage restant et le fixer (enroulé) derrière le réservoir d'eau.

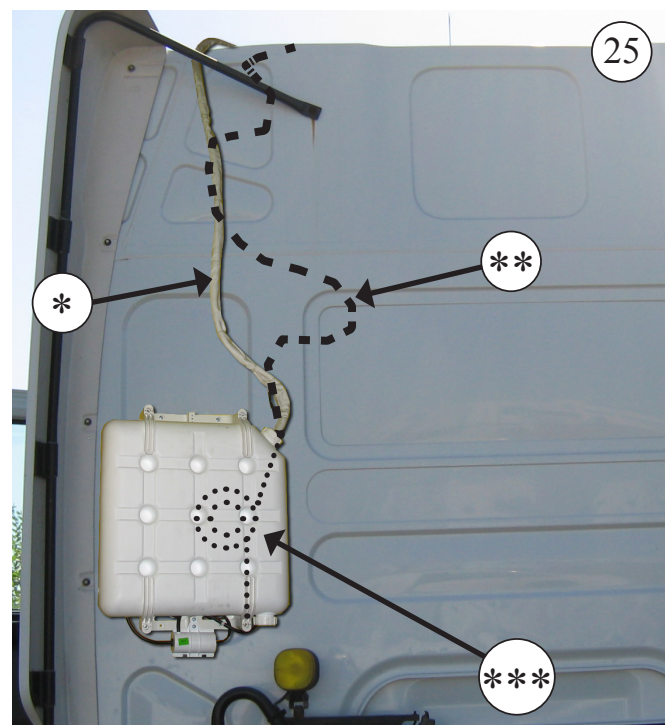

Important:

L'actionneur d'évaporation fonctionne en prenant l'air de l'extérieur qui est introduit dans la cabine. Il est important que cet air ne reste pas en suspens à l'intérieur, car cela produirait un excès d'humidité. Toutes les cabines des véhicules modernes sont munies de grilles de renouvellement de l'air, à travers lesquelles l'air nécessaire sort. Par exemple, pour le chauffage.

L'installateur devra s'assurer de l'existence de ces grilles et, dans le cas contraire, il devra les installer.

De son côté, l'utilisateur devra surveiller régulièrement que ces grilles ne sont pas bouchées par la saleté.

Instructions détaillées sur l'installation du câblage d'alimentation



Câblage
d'alimentation



1- Porter le câble d'alimentation jusqu'à la batterie du véhicule, en collant les supports en plastique sur la partie supérieure de la cabine et en les fixant avec des brides; ensuite, avec la cabine abattue, passer le câble à travers la partie inférieure de celle-ci en le fixant avec des anneaux et des vis M4; puis jusqu'à la batterie avec des brides; il faut utiliser le même passage que le câblage original. (*Pour coller les supports en plastique il faut d'abord bien nettoyer la surface*). Au moment de la connexion de l'équipement à la batterie, celui-ci fera un test sur tous ses leds, puis il s'éteindra.

IMPORTANT : en raison de la complexité du système de réglage électronique de l'équipement, la prise de courant doit se faire directement sur la batterie du véhicule, et non sur un tout autre point fournissant des services à d'autres accessoires du véhicule, en faisant attention de ne pas inverser la polarité au moment de la connexion (2). Si la polarité est inversée, des dommages irréparables peuvent se produire sur l'électronique qui ne seront pas couverts par la garantie.

IMPORTANT: Consulter le Manuel de l'Usager pour la mise en marche.



Schéma de câblage



POMPE EAU FLOTTEUR

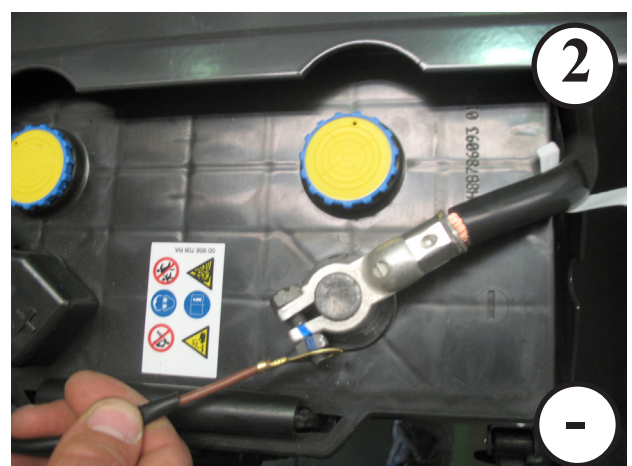
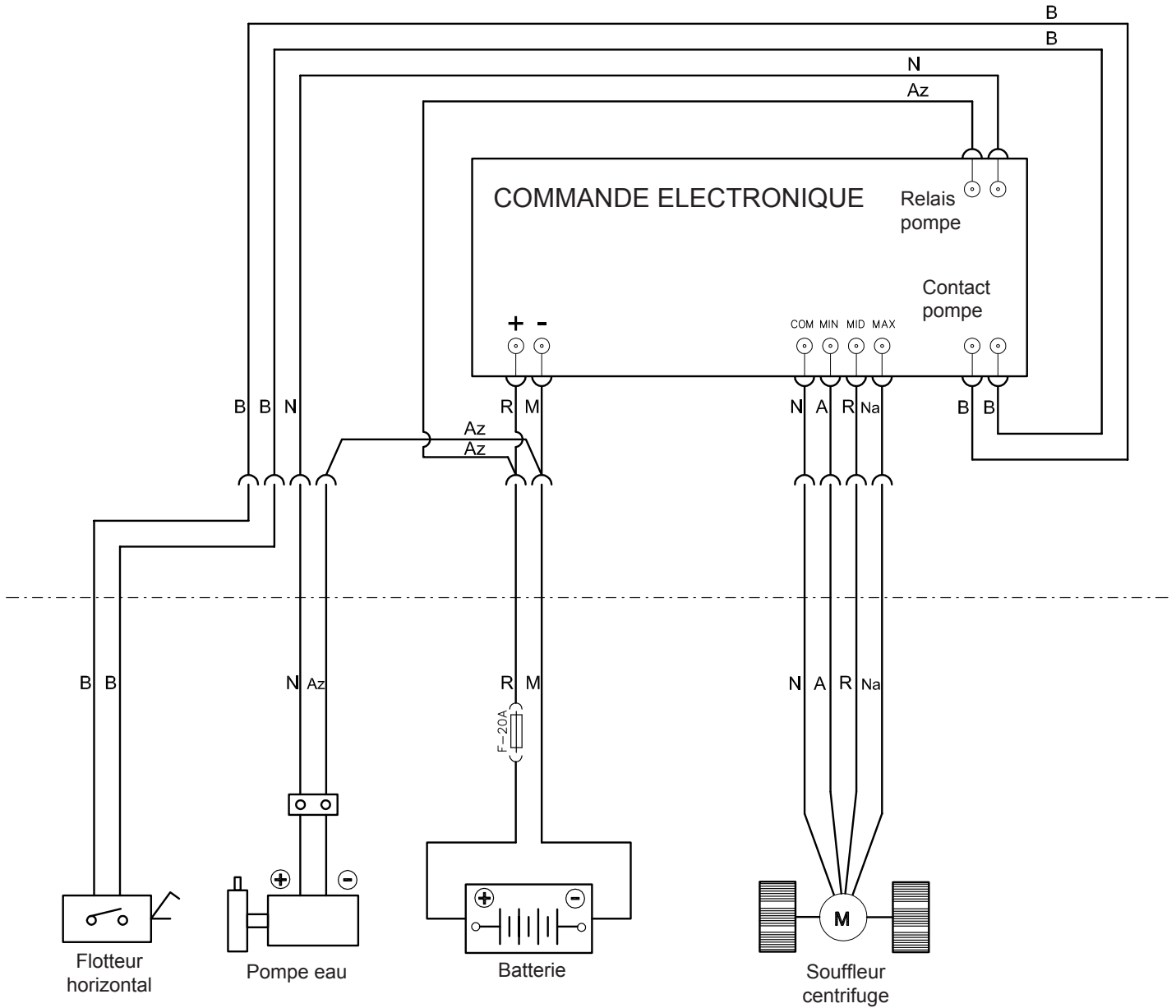
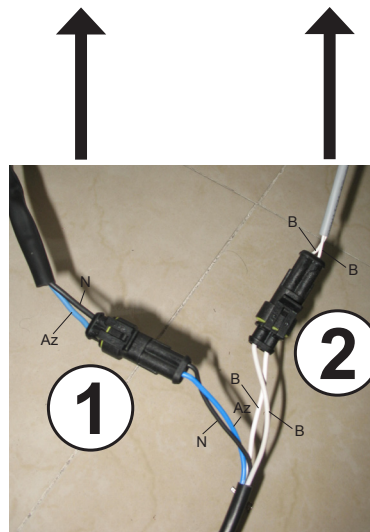

COULEURS

A	Jaune
Az	Bleu
B	Blanc
G	Gris
Na	Arancione
N	Noir
R	Rouge
Ro	Rose
V	Vert
Vi	Violet
M	Marron
Mo	Pourpre

**EMPFEHLUNGEN
ZUR MONTAGE**

- **Bevor Sie mit der Montage beginnen, lesen Sie diese Anweisungen sorgfältig und befolgen Sie sie im Verlauf der Installation.**
- **Vewenden Sie für jeden Arbeitsgang die geeigneten Werkzeuge.**

ELEKTRIZITÄT

- **Zündschlüssel ziehen.**
- **Vor Beginn der Montage Batterie abklemmen.**
- **Überprüfen Sie die Anschlüsse auf korrekten Sitz.**

Werkzeuge

Satz Torx-Schlüssel
Satz Inbusschlüssel
10er, 13er, 14er - Gabelschlüssel
Schere
Biegeprüfgerät

**DER ANLAGE BEIGEPACKTE
DOKUMENTATION:**

- **Montageanweisungen: 220.AA7.0001**
- **Benutzerhandbuch: 220.AA7.0003**
- **Fehlerdiagnose: 220.AA7.0004**
- **Garantie: 220.AA1.0010**

WICHTIGER HINWEIS:

Wird die Verdampferanlage im Kabinendach installiert, muss der obere Teil der Kabine mit einem Tuch oder einer Decke gegen eventuelle Kratzer geschützt werden. Bei der Installation des Bycool Flat an der Decke ist zu berücksichtigen, dass die Konstruktion von Kabinen mit Luke normalerweise ausreicht, um das Gewicht der Anlage zu tragen. Sollte die Kabine jedoch keine Luke haben und die Decke aufgeschnitten werden müssen oder, bei vorhandener Luke das Material nicht ausreichend widerstandsfähig sein (bei Decken aus Faser, Kunststoff usw.), obliegt es dem Installateur unter seiner Verantwortung über die Notwendigkeit zu entscheiden, die Decke anhand entsprechender Mittel zu verstärken, um evt. Verformungen, Brüche, Eindringen von Wasser usw. zu verhindern.

HINWEISE:

- Teil 17 der Liste der Lieferteile muss alle 12 Monate ausgetauscht werden.
- **dirna Bergstrom, s.l.** übernimmt keine Haftung bei Schäden durch unsachgemäßen Umgang mit der Anlage oder deren falschen Einbau oder durch ohne unsere ausdrückliche schriftliche Zustimmung vorgenommene Änderungen und ausgetauschte Komponenten.
- Bitte beachten Sie **Gewährleistungsverfahren** des Produktes einschließlich **Fehlerdiagnose**.
- Zum korrekten Einsatz der Fernbedienung und der Steuertafel verweisen wir auf das Benutzerhandbuch der Anlage.

1 Lukendeckel, und Befestigungsteile abnehmen und dem Kunden übergeben (*).



1a Sollte keine Luke vorhanden sein, wäre die Decke gemäß den angegebenen Mindestabmessungen auszuschneiden.

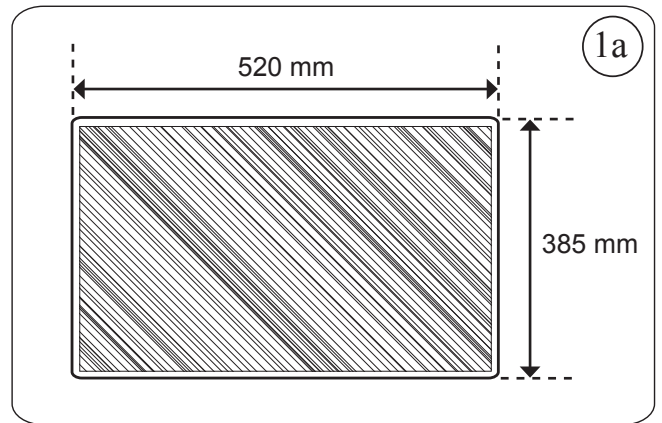

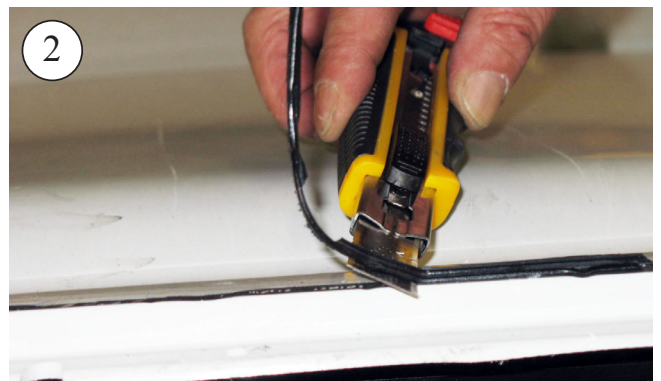
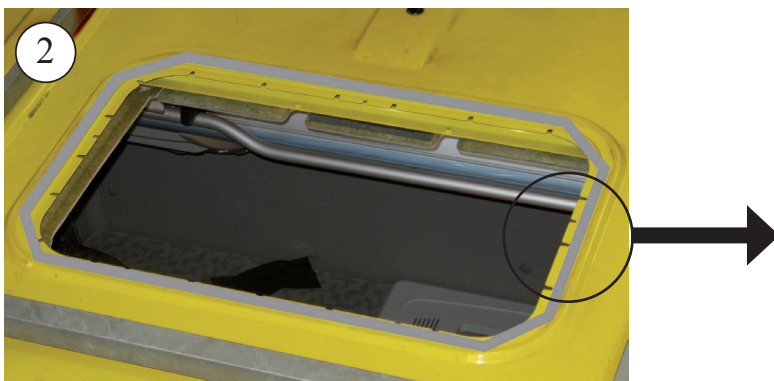

Mindestabmessungen für den Einschnitt in Kabinendach ohne Luke

2 Bevor die EPDM-Dichtung verklebt wird, überschüssige Reste von der Decke entfernen.

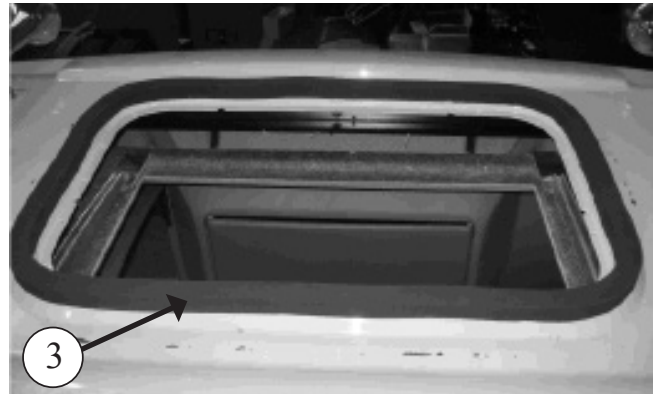

3 Kleben Sie die EPDM –Dichtung um die Lukenöffnung (beachten Sie die Hinweise zum Beschneiden der Abschlussverbindungskanten der Dichtung)



 **SOWIRD DIE EPDM-DICHTUNG BESCHNITTEN, UM DAS EINSICKERN VON WASSER IN DAS FAHRERHAUS ZU VERMEIDEN:**

A- Dichtung so verkleben, dass 100 mm Schutzpapier an jeder Seite überstehen.

B- Entfernen Sie die beiden Papierstücke.

C- Drücken Sie die beiden Endstücke an.

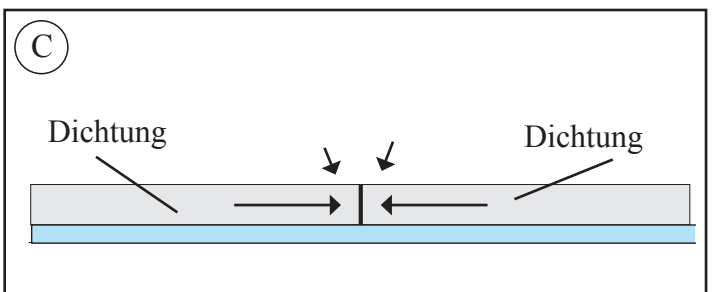
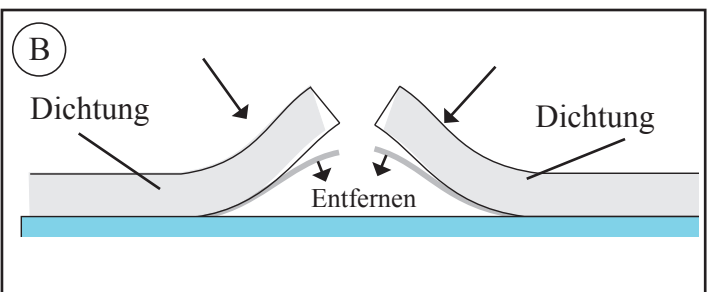
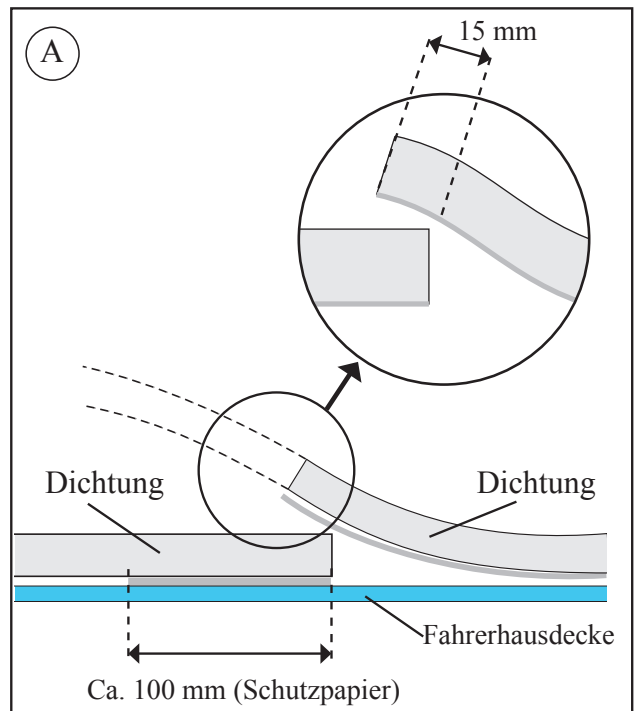

4 **FAHRERHAUS, AUSSEN:**
Bycoolanlage in der Lukenöffnung positionieren.



5 **FAHRERHAUS, INNEN:**
(4) Stiftschrauben 8/125x100 oder 120 ca. 5 mm eindrehen. Das Maß wird nach der Positionierung der Befestigungsstützen gewählt, wobei zu berücksichtigen ist, dass die Stiftschrauben nach unten 10 mm überstehen müssen

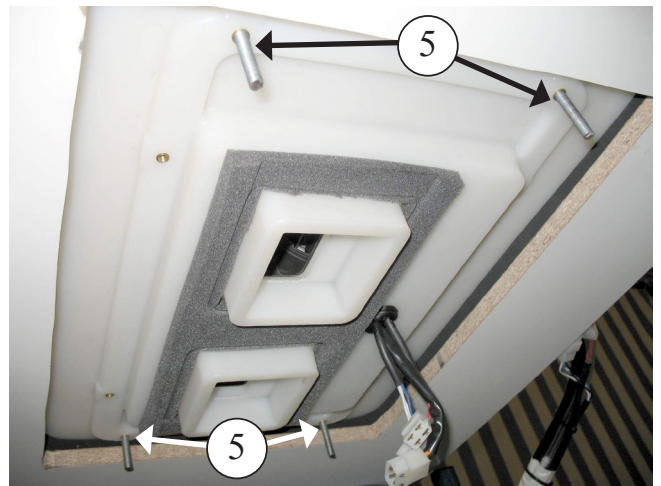
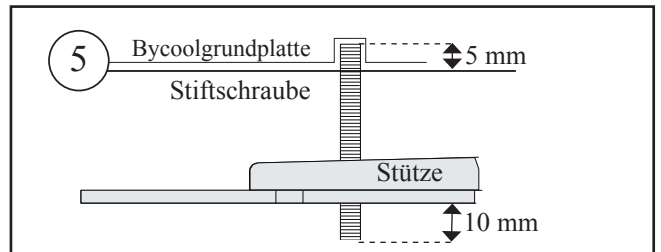

6 An jeder der obigen Stiftschrauben (1) Gummis-
scheibe Ø 7, (1) Breitflanschflachscheibe Ø 8, (2)
M8-Muttern und (1) Breitflanschflachscheibe Ø 8
einlegen.

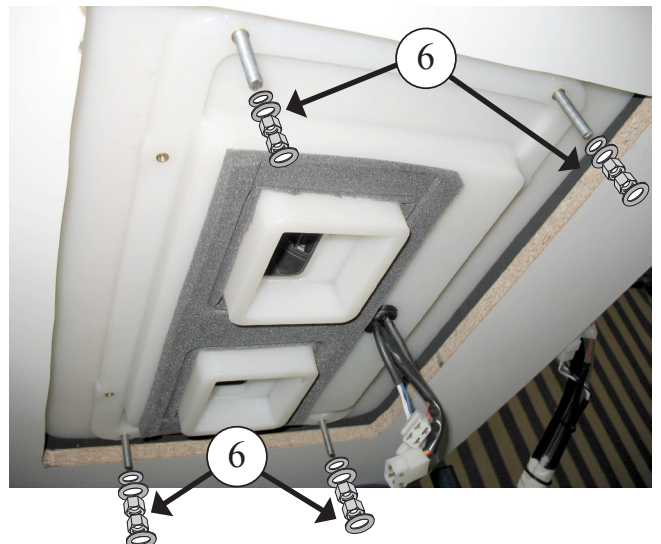

6a

(2) Befestigungsstützen mit (1) Scheibe und (1) selbstblockierende M8-Mutter eindrehen, jedoch **ohne sie anzuziehen**.



7

(4) Stiftschrauben M6 x 55 oder 80 10 mm an der angegebenen Stelle eindrehen, und zwar von der Höhe (A) der Skizze, Punkt 9.

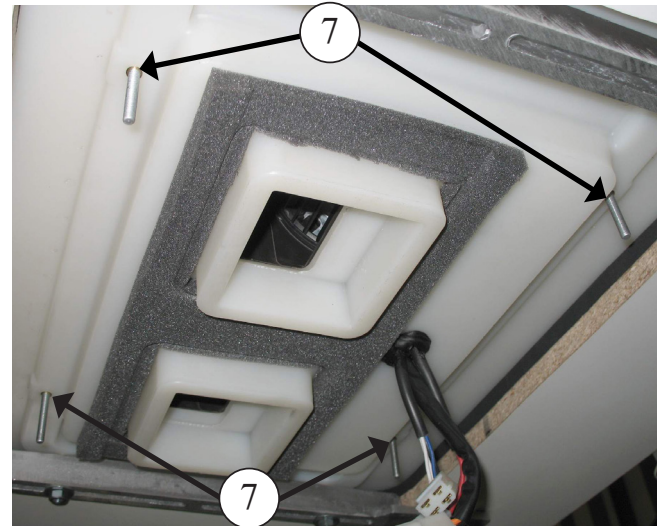

8

(1) Gummischeibe Ø6, (1) Breitflanschscheibe Ø6 und (1) Mutter M6 auf jede der Stiftschrauben M6 legen. **Mutter festziehen**.



8a An jeder Stiftschraube (1) Mutter M6 einlegen, **ohne diese jedoch anzuziehen.**

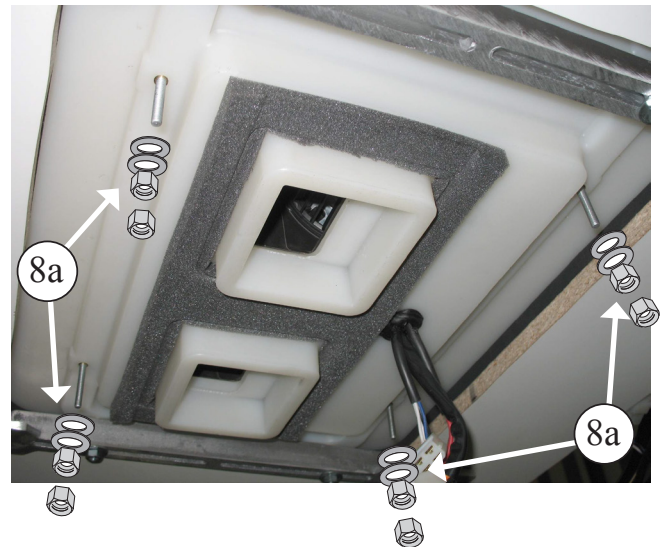

8b Kabelführungen mit LOCTITE Superglue 3 oder ähnlich an die innere Luftverteiltertafel ankleben, um die Montage der Einheit zu erleichtern und die Kaltluftströme durch die Durchlassgitter zu garantieren.

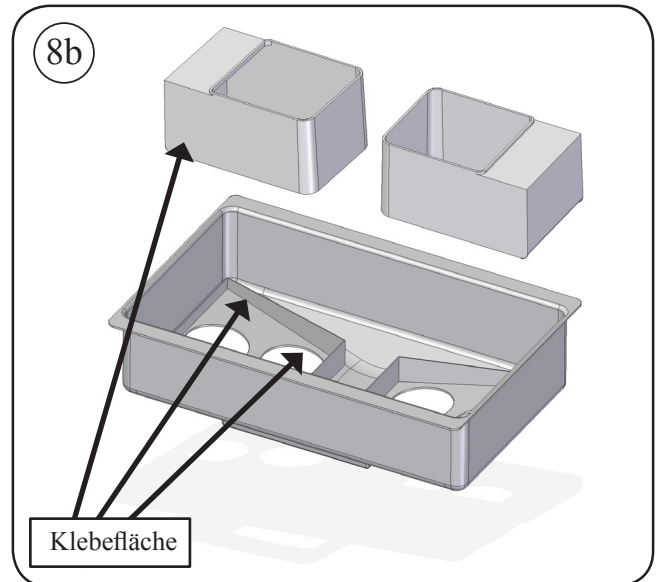

8c Die (2) 4-Wege-Kästen und (1) 2-Wege-Kasten der inneren Luftverteiltertafel mit denen des Bycool verbinden.

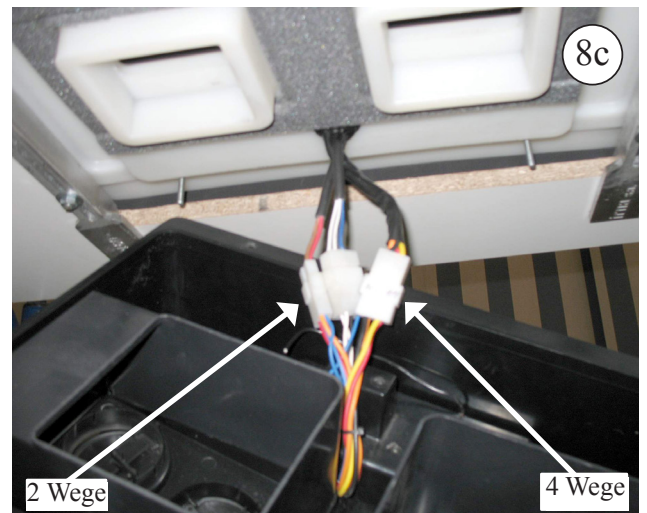

9 Innere Luftverteiltertafel an den vorgenannten Stiftschrauben mit jeweils (1) Breitflansch-Unterlegscheibe M6 und (1) Mutter M6 anbringen. Muttern anziehen, bis die Kabelführungen am oberen Schaumgummi der Anlage anliegen.
Wichtig: Die Führungen müssen an das Schaumgummianschlagen, um Luftleckagen zu vermeiden.

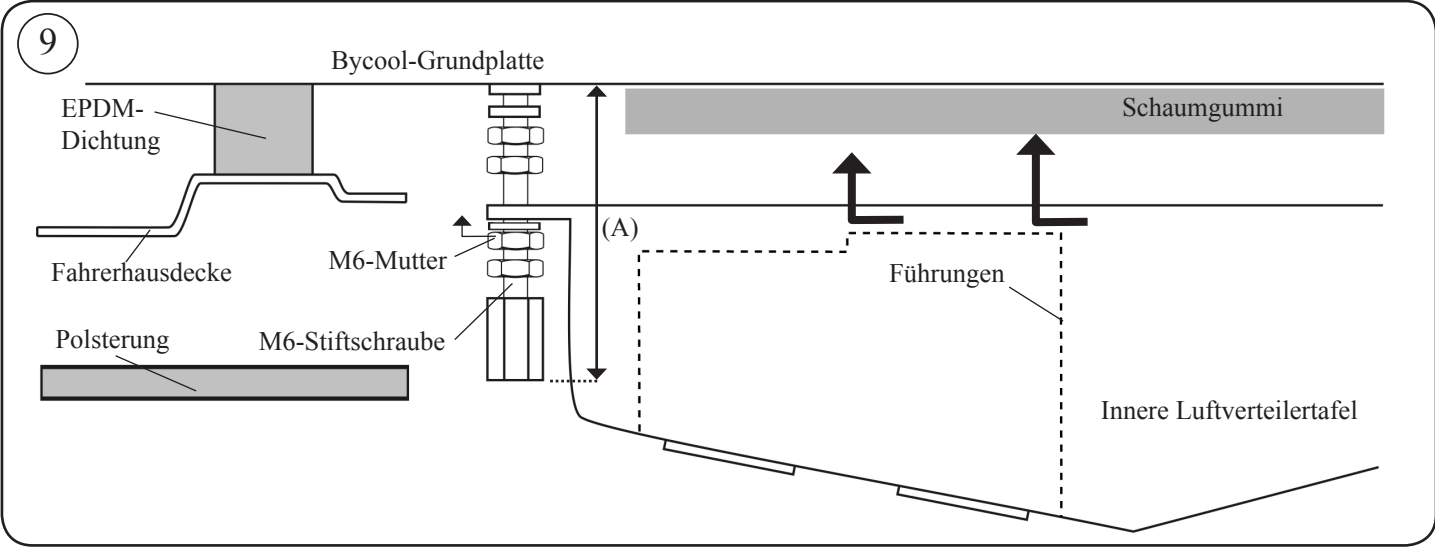

10 Mutter aus Punkt 6a anziehen, bis diese an das Oberteil der inneren Luftverteiltertafel stößt.

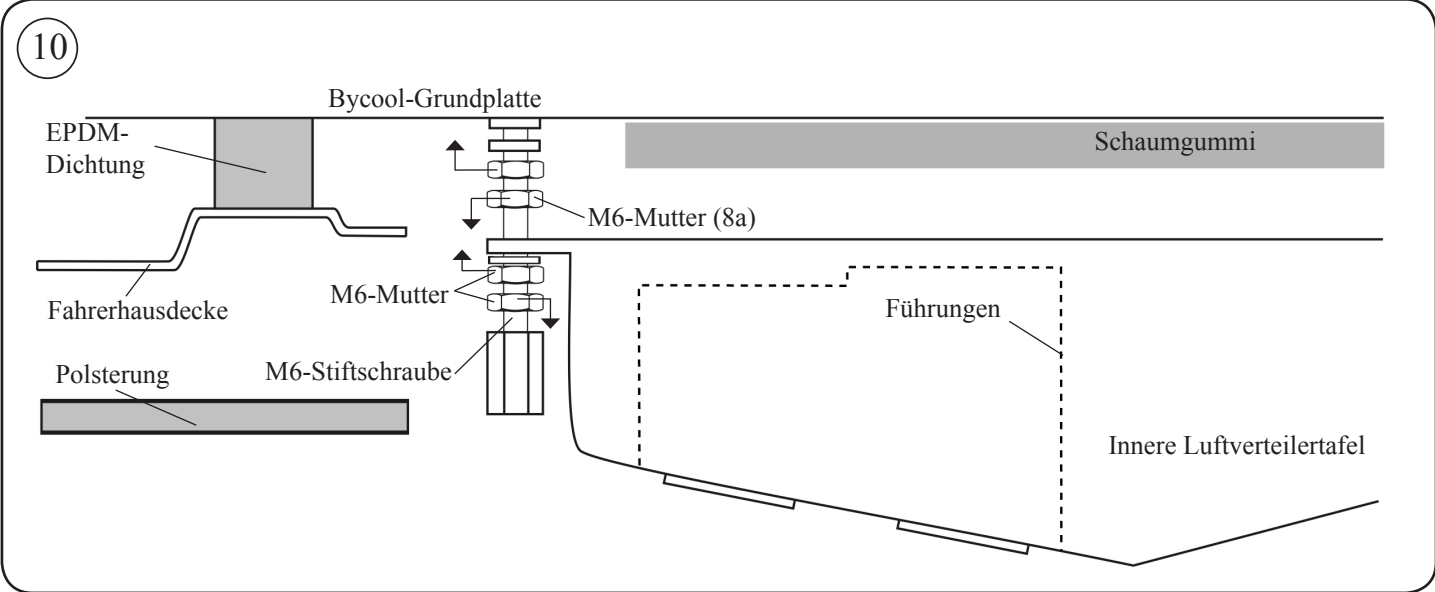

11 Konsole positionieren und Anlage an der am besten geeigneten Stelle der Fahrerhausdecke zentrieren. Nach dem Zentrieren Konsole wieder abnehmen.

12

Bringen Sie die Befestigungsstützen an, indem Sie die Muttern anziehen, bis die EPDM-Außendichtung 3-6 mm auf der Anlage festsetzt.

Wichtig: Als Schutz gegen eventuelle Einsickerungen von Wasser in das Fahrerhausinnere muss die EPDM-Dichtung, wie auf der Skizze angegeben, auf der Grundplatte der Bycool-Anlage sicher angezogen sein.

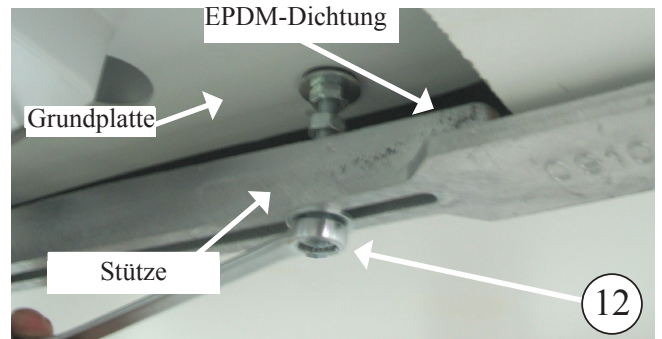
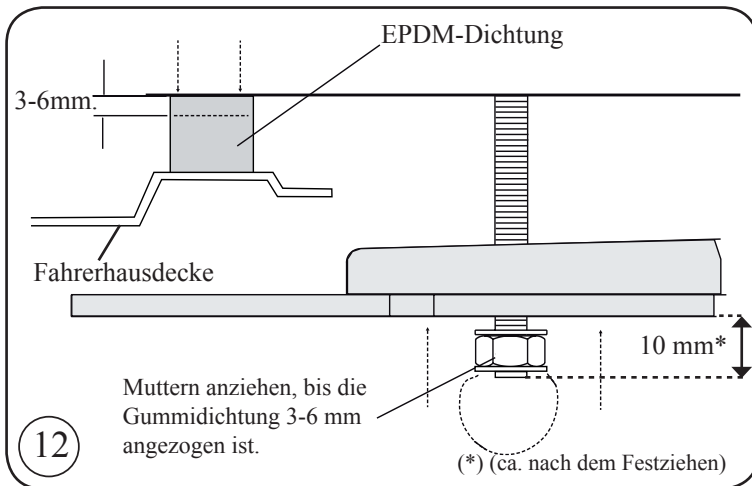

13

(4) Muttern M8 an der Stütze und (4) an der Bycool-Grundplatte festziehen.

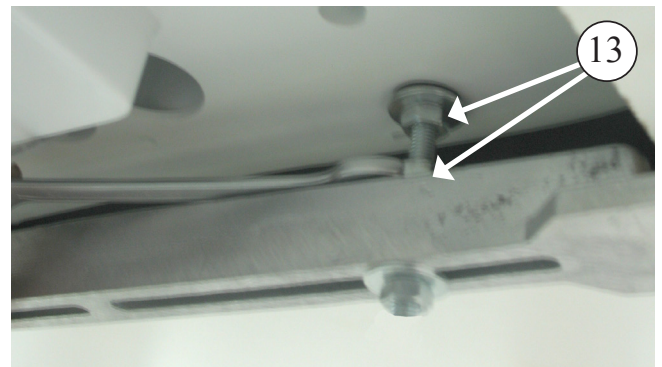

14 Eine Mutter M6 (A) hinter der Befestigungsmutter der inneren Luftverteiltertafel an allen Stiftschrauben anbringen. Sechskant-Verbindmuttern M6 eindrehen, bis sie 1 mm über dem Bezug herausstehen. Muttern M6 (A) dieses Punkts heraus-schrauben, bis sie an die Sechskant-Verbindmuttern anstoßen, und gegen diese anziehen.

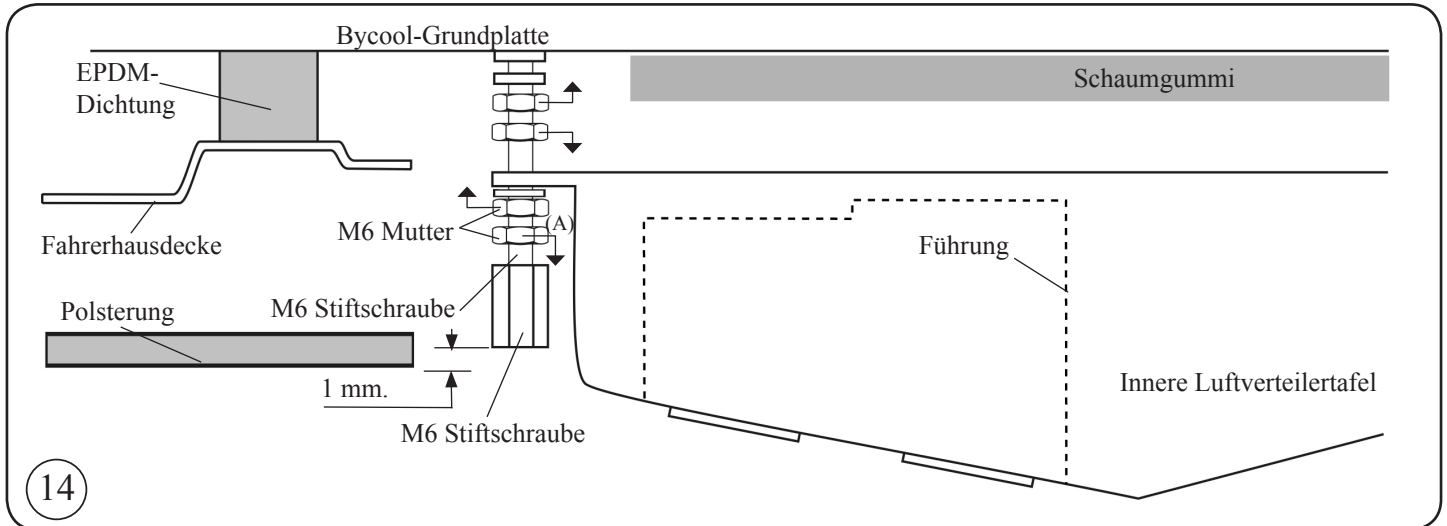
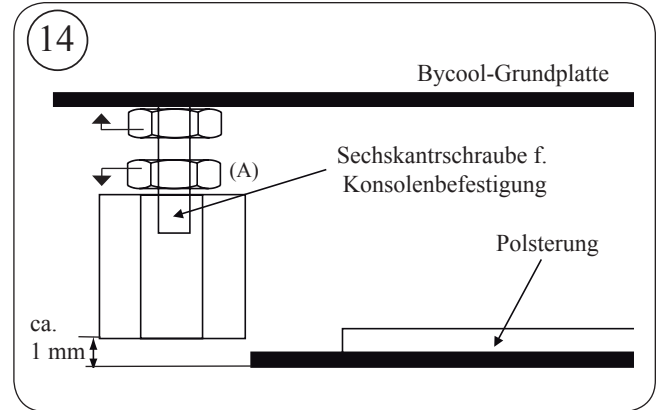

15 Konsole mit (4) Inbusschrauben M6/100x15 anbringen.

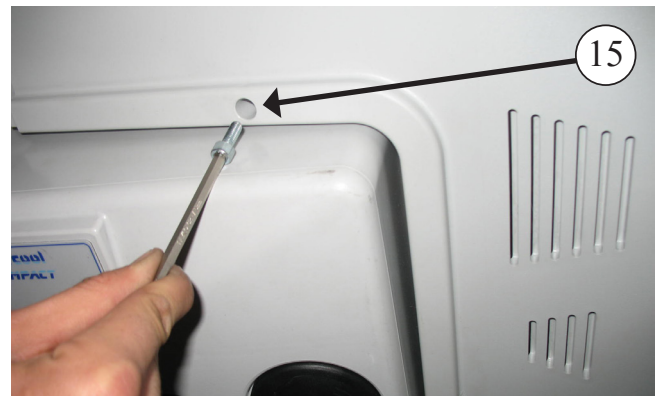

15a Die (4) Inbusschrauben M6/100x15 mit runden Kunststoffzierkappen M6 abdecken.

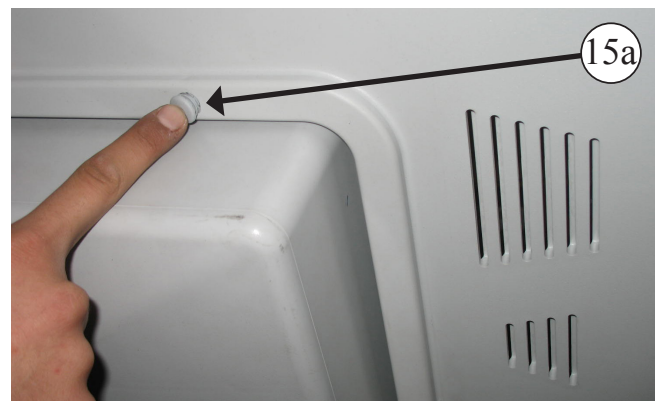

Übersichtsbild bis zur befestigung der stützen

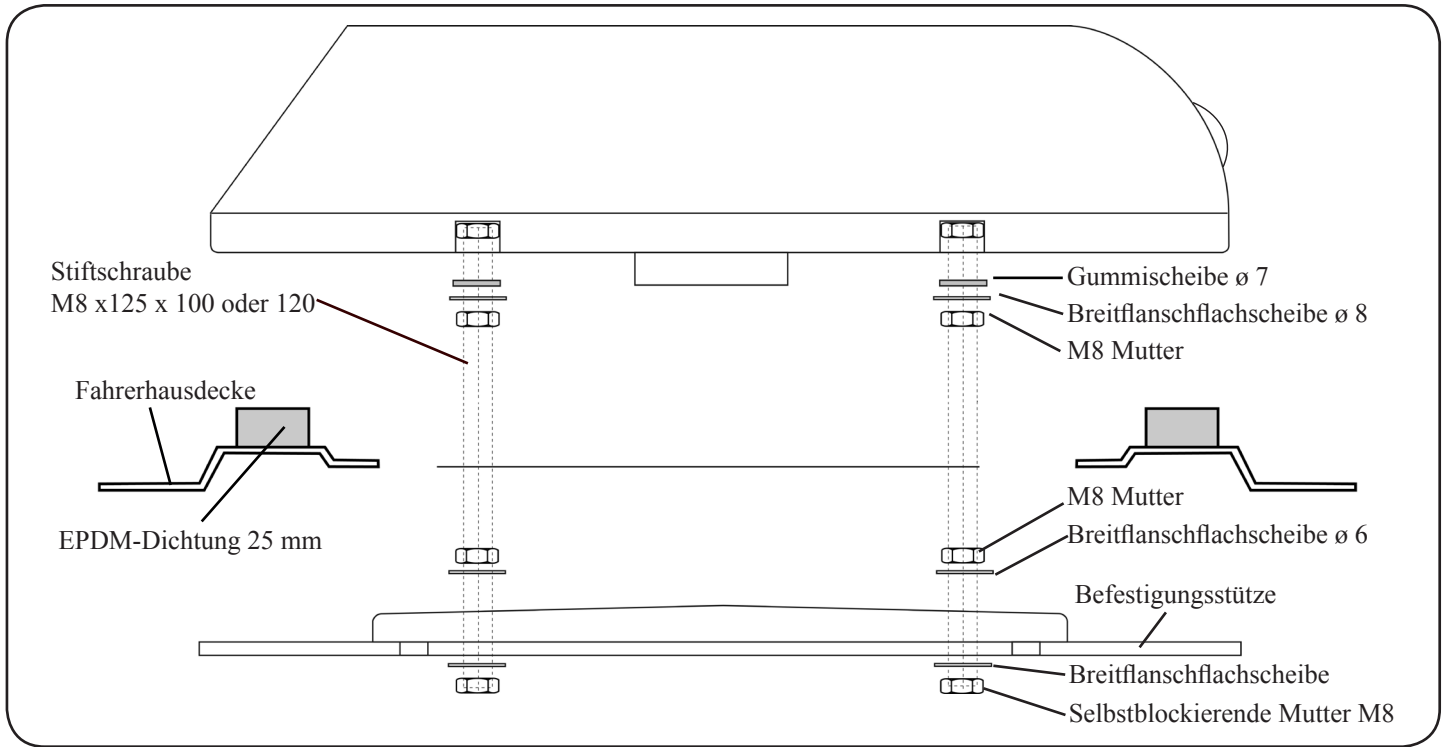

Übersichtsbild bis zur befestigung der konsolen

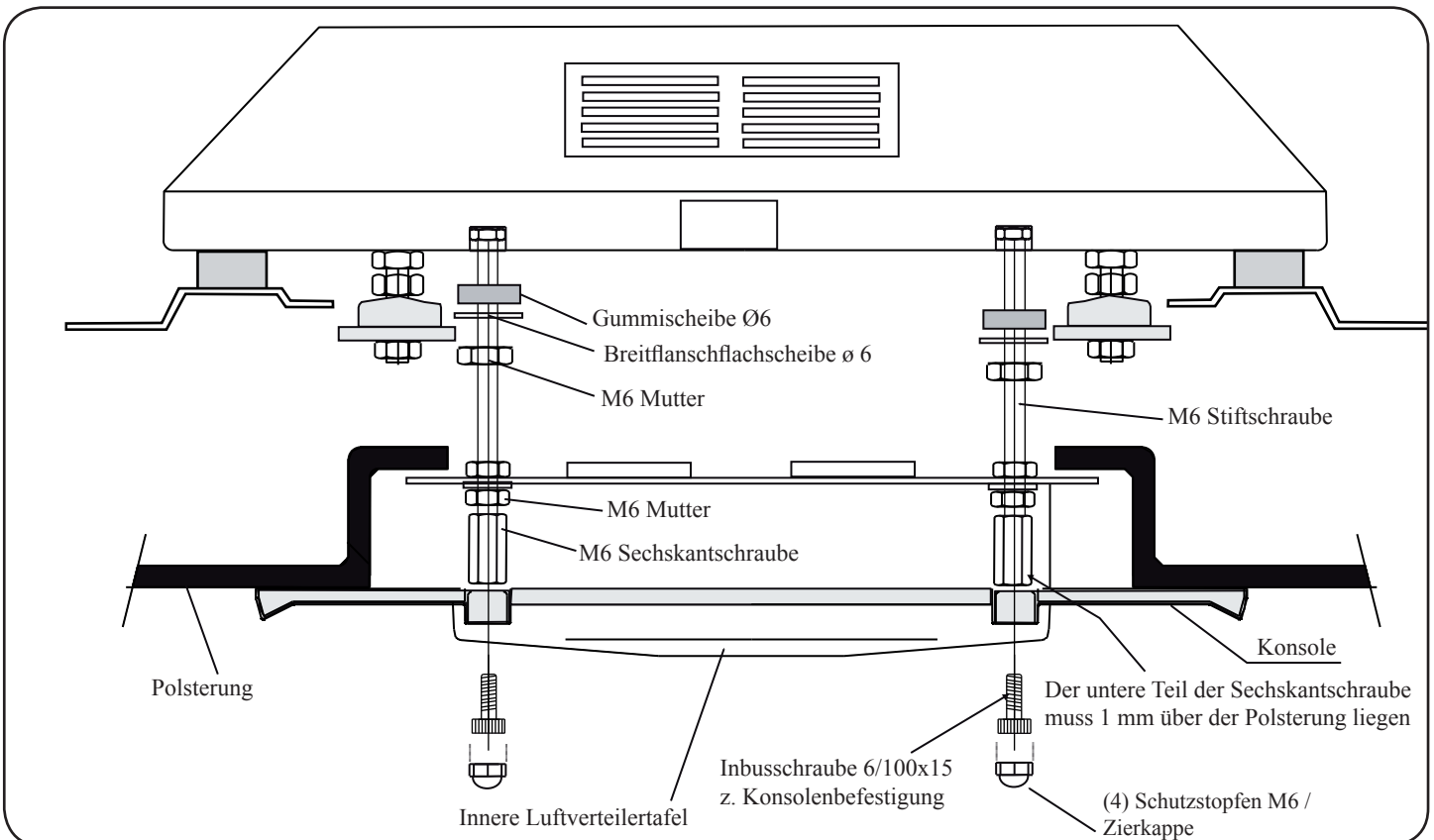

16

Verkabelte und verrohrte Kästen von hinten, wie dargestellt, an der Bycool-Anlage befestigen.

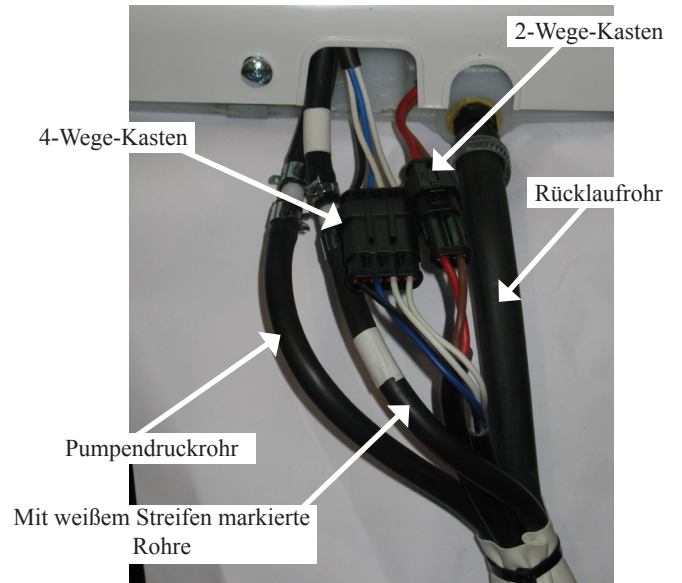

17

Behälterstütze an einem geeigneten, ziemlich weit unten liegenden Punkt im hinteren Bereich des Fahrerhauses positionieren. Ø 9 im Fahrerhaus markieren und bohren. Beachten Sie dabei die senkrechte Position der Stütze. Mindestens (6) Befestigungsbohrungen.



18

Nietmuttern M6 anbringen und Stütze mit Schrauben 6/100x30 befestigen. (*) – In Fällen, in denen die Stütze nicht auf einem glatten Teil aufliegt, 10 mm Abstandhalter und Schraube 6/100 x 40 einsetzen.

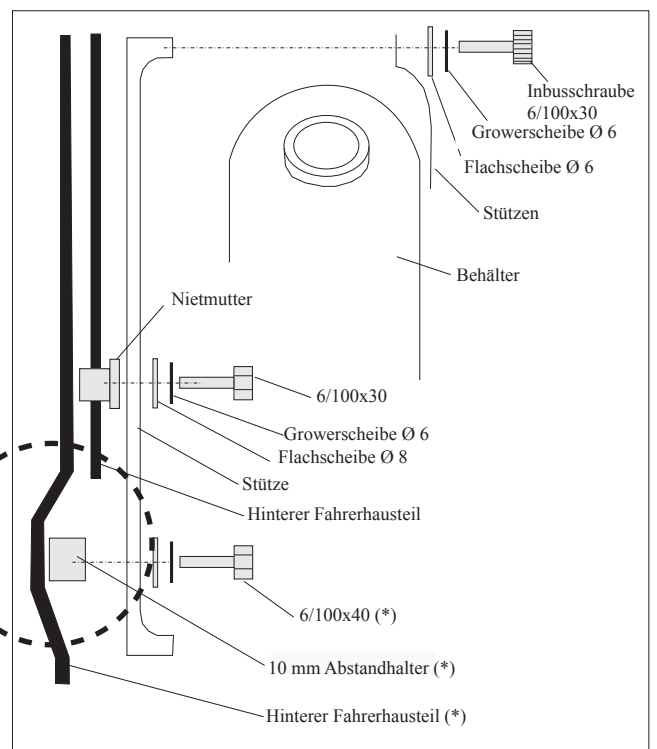

19

Pumpenanordnung am Behälter mit (2) Blechgewindeschrauben 5.4x19 mm befestigen.



20

Anschließend Pumpenrohr (X) an Behälter anschließen und Behälter (wählen Sie dazu die optimale Position des Füllstopfens, rechts oder links, um die Füllung zu erleichtern) mit den mitgelieferten Stützen befestigen. Die Stütze mit Absatz wird verwendet, wenn der Behälter mit dem Füllstopfen (Y) auf der linken Seite eingebaut wird.

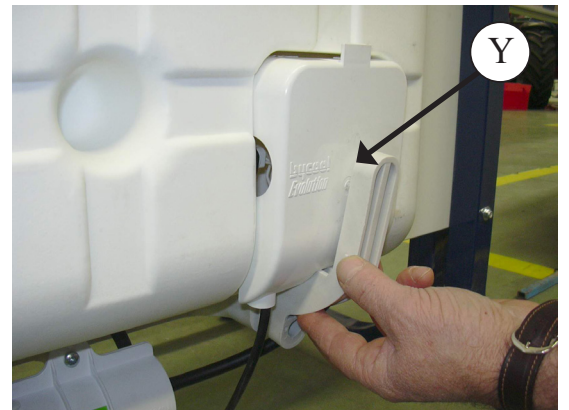
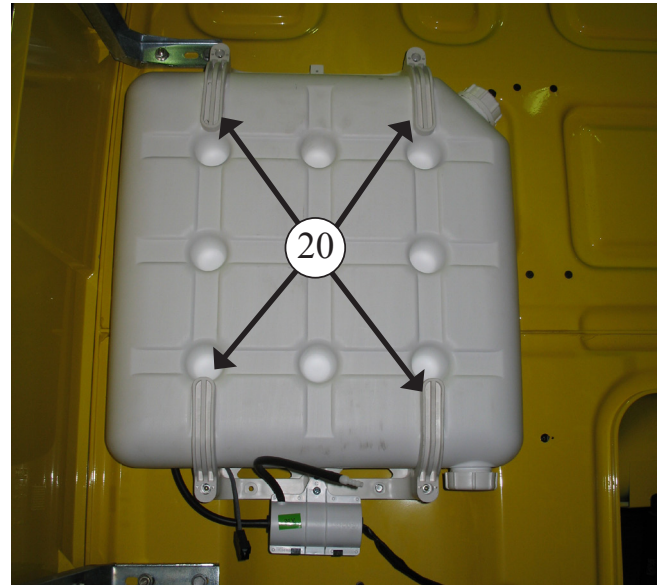

21 Filter in das Zapfenrohr einbauen, in den Stopfen einführen und an das Rücklaufrohr Ø18 x Ø12 (A).anschießen.

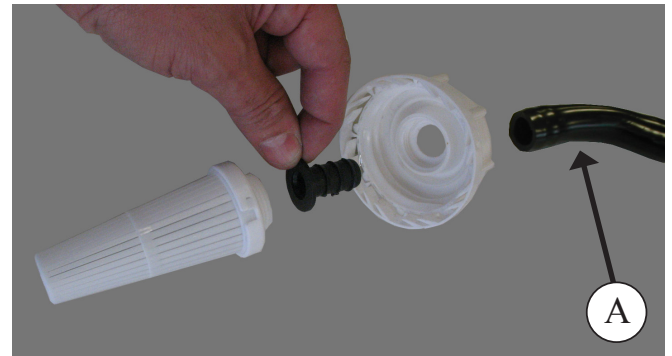

22 Stopfen in den Behälter einsetzen, auf 100 mm zuschneiden, "T" einschieben und daran das Rohr mit dem kleineren Querschnitt anschließen, **Dieses ist mit weißem Streifen gekennzeichnet. Vergewissern Sie sich, dass die Biegung ausreicht, um Drosselungen zu vermeiden.**



23 Verkabelung mit Hülle an die Kästen der Verdampferanlage und das Wasserzulaufrohr anschließen.

- A. Das von der Verdampferanlage kommende Druckrohr an die Pumpe anschließen.
- B. Pumpen- und Niveauperkabelung anschließen.

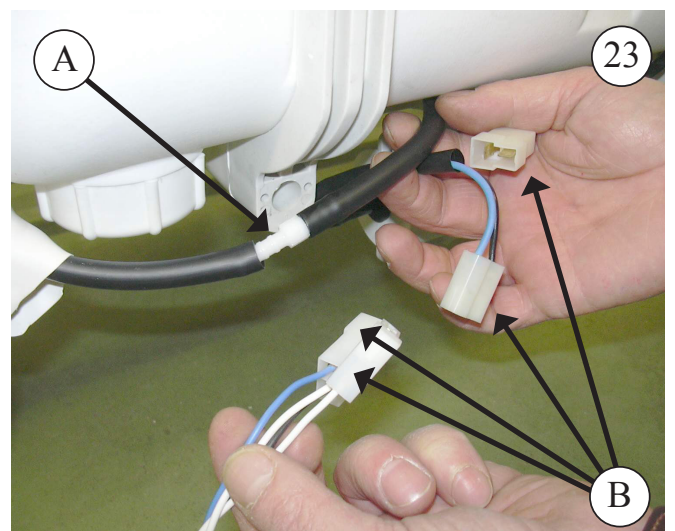

24

Batterieverkabelung wie dargestellt anschließen.



25

Entwässerungsrohr

(*) Korrekte Installation erfolgt an dem Punkt, an dem das Entwässerungsrohr Gefälle aufweist, um Schleifen und Drosselungen zu vermeiden und den Wasserzulauf in den Behälter zu erleichtern..

(**) Falsch. Darf so nicht ausgeführt werden.

(***) Überschüssige Verkabelung AUF KEINEN FALL ABSCHNEIDEN, sondern (zusammengerollt) hinter dem Wasserbehälter befestigen.

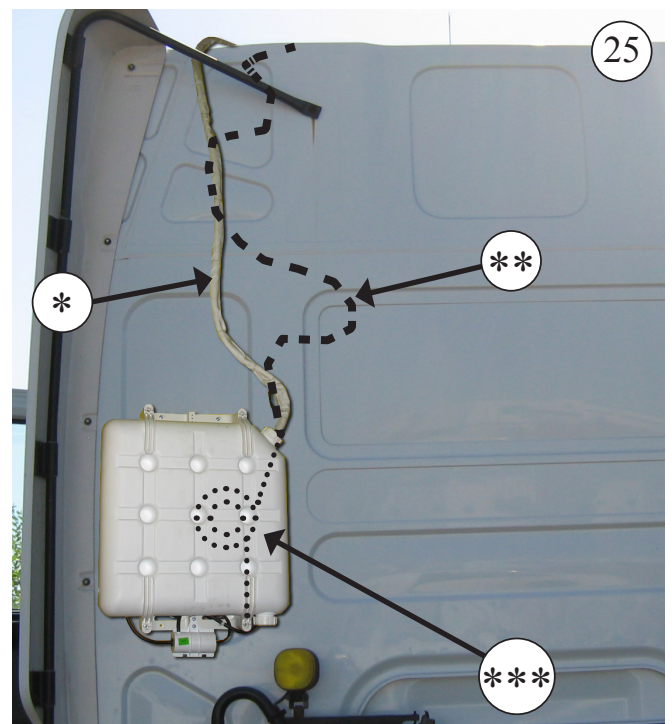

Wichtiger Hinweis:

Die Verdampferanlage saugt Außenluft an und leitet sie ins Fahrerhaus. Es ist außerordentlich wichtig, dass sich diese Luft nicht im Fahrerhaus staut, da sonst zu große Feuchtigkeit entstehen würde. Alle modernen Fahrzeugen besitzen Fahrerhäuser mit Lüfterneuerungsgitter, durch die die erforderliche Luftmenge entweichen kann. Beispielsweise für die Heizung.

Der Installateur muss sich vergewissern, dass diese Gitter vorhanden sind. Ist das nicht der Fall, dann müssen sie eingebaut werden.

Der Benutzer muss seinerseits diese Gitter regelmäßig auf eventuelle Verstopfung prüfen.

Detaillierte Anweisungen zur Installation der Versorgungskabel



Versorgungs-
verkabelung



1- Versorgungskabel der Anlage bis zur Fahrzeugbatterie führen und dabei die Kunststoffstützen innen im Fahrerhaus aufkleben und mit Flanschen befestigen. Anschließend das Kabel bei heruntergeklapptem Fahrerhaus durch das Innere des Fahrerhaus führen und mit Schellen und M4-Schrauben befestigen, bis zur Batterie mit Schellen. Dabei ist der gleiche Durchlass wie für das Originalkabel zu verwenden. (Zum Aufkleben der Kunststoffstützen muss die Fläche vorher gereinigt werden). Beim Anschluss der Anlage an die Batterie führt die Anlage auf allen LEDs einen Test durch und erlischt dann.

WICHTIG: Aufgrund des komplexen elektronischen Steuerungssystems der Anlage muss die Stromversorgung direkt von der Fahrzeugbatterie und nicht von einem anderen Versorgungspunkt für sonstiges Fahrzeugzubehör aus erfolgen, wobei darauf zu achten ist, dass beim Anschluss die Polarität nicht vertauscht wird (2). Wird die Polarität vertauscht, kann es zu irreparablen Schäden an der Elektronik kommen, welche nicht durch die Garantie abgedeckt sind.

WICHTIG: Näheres zur Inbetriebnahme finden Sie im Benutzerhandbuch.

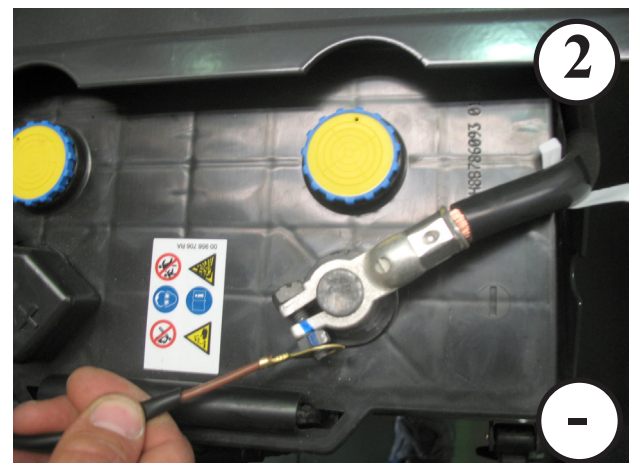

Schaltkreis

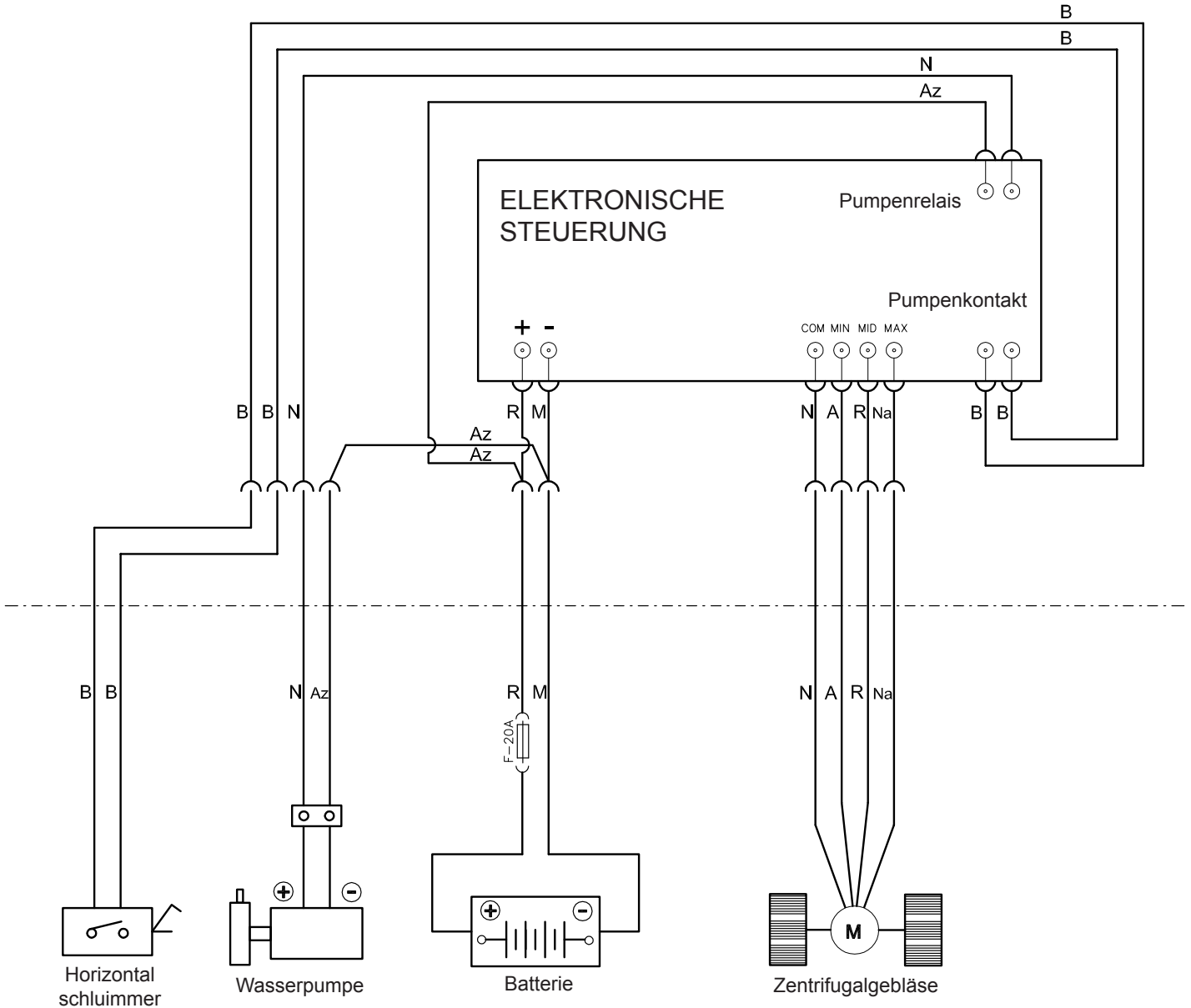

WASSERPUMPE SCHWIMMER

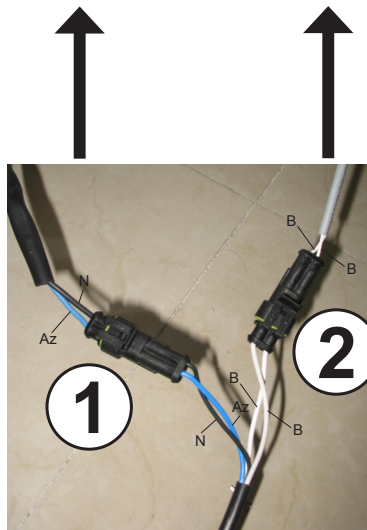

FARBEN

A	Gelb
Az	Blau
B	Weiss
G	Grau
Na	Orange
N	Schwarz
R	Rot
Ro	Rose
V	Grün
Vi	Violett
M	Braun
Mo	Dunkelviolett

RACCOMANDAZIONI PER IL MONTAGGIO

- Prima di iniziare il montaggio leggere le istruzioni e seguirle durante il processo di installazione.
- Usare gli strumenti adeguati per ogni operazione.

ELETTRICITÀ

- Scollegare la chiave di contatto.
- Scollegare la batteria prima di iniziare il montaggio.
- Garantire il collegamento dei componenti elettrici, verificandone il corretto inserimento.

Strumenti

Set Chiavi Torsiometriche

Set Chiavi a Brugola

Chiave fissa 10, 13, 14

Forbici

Flessometro

DOCUMENTAZIONE INCLUSA NEL DISPOSITIVO:

- Istruzioni di Montaggio: 220.AA7.0001
- Manuale dell'Utente: 220.AA7.0003
- Diagnosi di Guasti: 220.AA7.0004
- Garanzia: 220.AA1.0010

ATTENZIONE:

Quando si installa il dispositivo evaporativo sul tetto bisogna proteggere la parte superiore della cabina con un panno o una coperta di protezione, per evitare eventuali graffi. Quando si installa **Bycool Flat** sul tetto bisogna considerare che, normalmente, le cabine con tettuccio hanno una struttura sufficiente per sostenere il peso del dispositivo. Tuttavia, se così non fosse e se si dovesse realizzare un taglio sul tetto o se, pur avendo il tettuccio, il materiale non fosse sufficientemente resistente (se il soffitto è di fibra, plastica, ecc...) spetterà all'installatore decidere, **sotto la sua responsabilità**, circa la necessità di rinforzare il tetto per evitare eventuali deformazioni, rotture, infiltrazioni di acqua, ecc... con i mezzi adeguati affinché ciò non accada.

AVVERTENZE:

- Il pezzo N. 17 dell'elenco di Pezzi Forniti si deve sostituire ogni 12 mesi.
- **dirna Bergstrom, s.l.** non assume alcuna responsabilità in caso di guasti provenienti da una manipolazione o installazione del dispositivo inadeguata, o da modifiche e sostituzioni effettuate senza la nostra autorizzazione espressa per iscritto.
- Vedi **procedimento di garanzia** del prodotto in **Diagnosi di Guasti**.
- Vedi Manuale dell'Utente del dispositivo per il corretto funzionamento del telecomando e del pannello di controllo.

1 Smontare coperchio tettuccio, gli elementi di fissaggio e consegnarli al cliente (*).



1a In caso di assenza dello sportello, tagliare il soffitto secondo le dimensioni minime indicate.

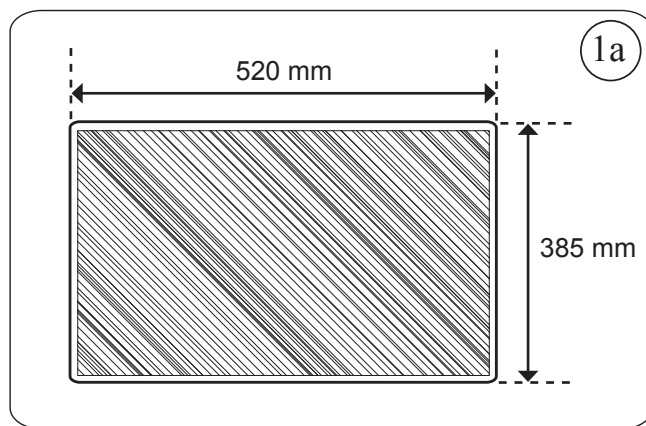

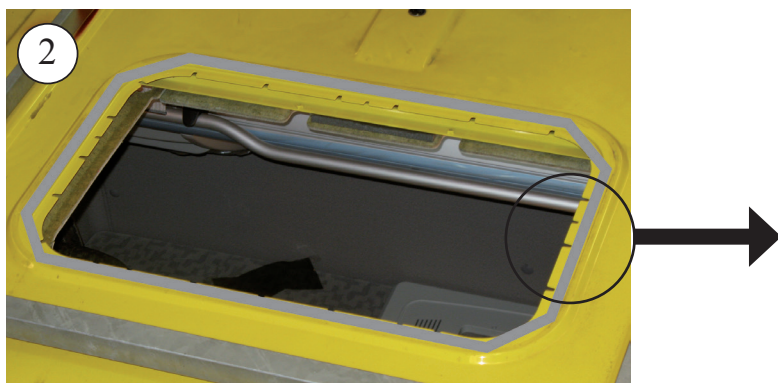

Dimensioni minime per il taglio sul tetto della cabina, se non dispone di un oblo'

2 Togliere i residui in eccesso attaccati al soffitto prima di incollare la guarnizione EPDM.

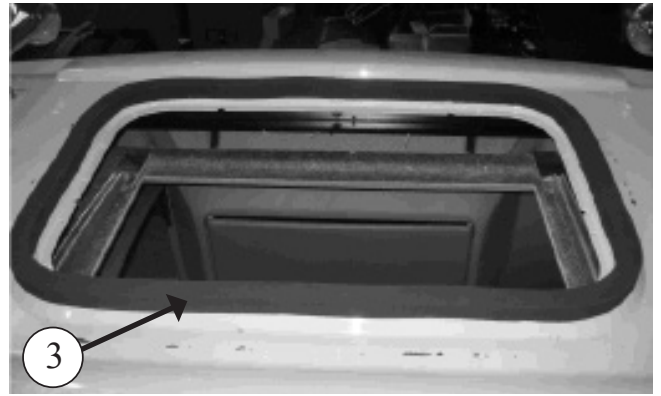

3 Incollare la guarnizione EPDM intorno al vano del tettuccio (*osservare i particolari per tagliare i bordi finali di unione della guarnizione*).



 **COME TAGLIARE LA GUARNIZIONE EPDM PER EVITARE LA FILTRAZIONE D'ACQUA NELLA CABINA**

A- Incollare la guarnizione, mantenendo 100 mm di carta protettiva su ogni lato.

B- Togliere i due pezzi di carta.

C- Incollare premendo entrambe le estremità.

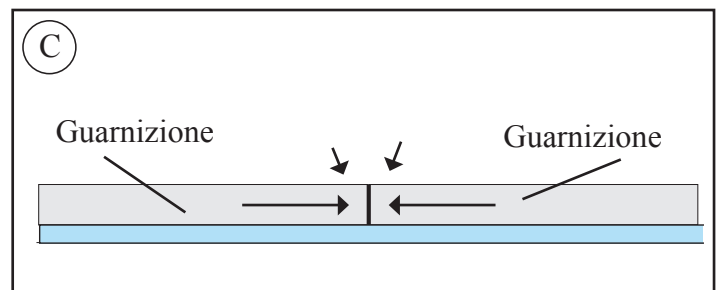
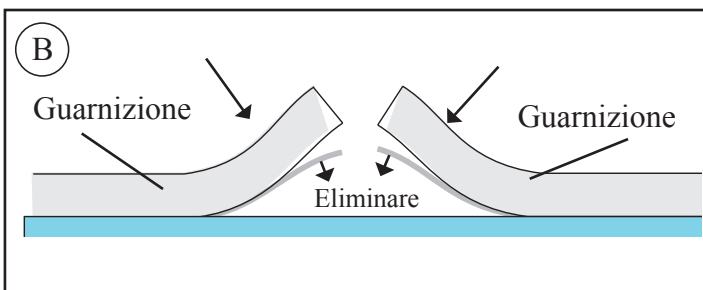
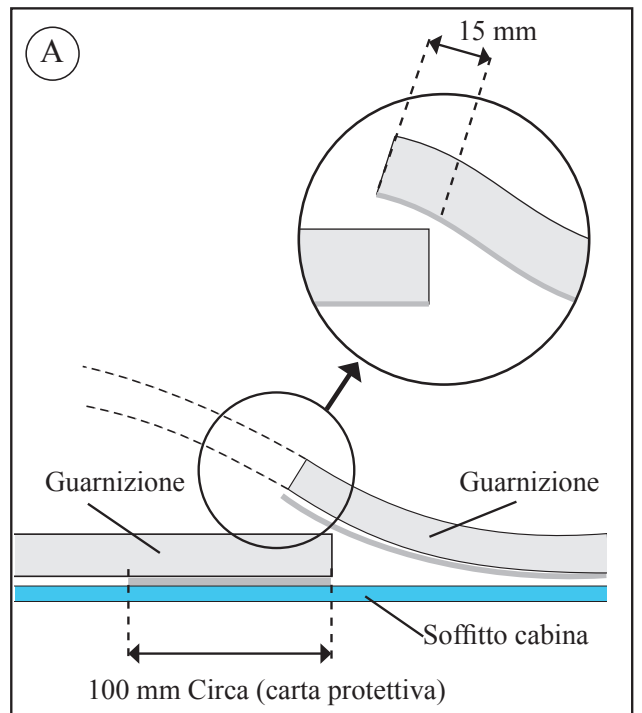

4 **ESTERNO CABINA:**
Collocare il Bycool nel vano del tettuccio.

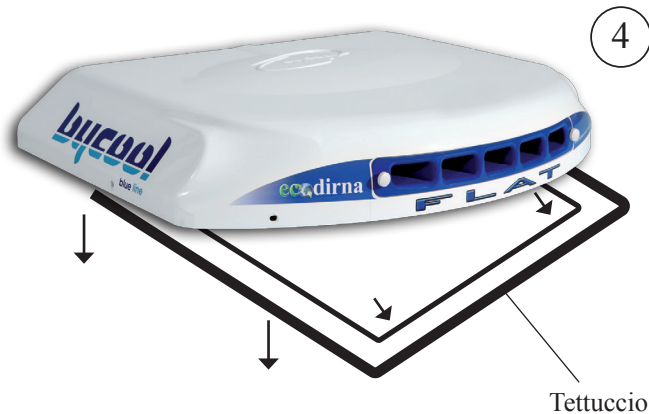

5 **INTERNO CABINA:**
Avvitare circa 5 mm (4) viti prigioniera 8/125x100 o 120, la misura verrà scelta dopo aver collocato i supporti di fissaggio e considerando che le viti prigioniera devono fuoriuscire dagli stessi dalla parte inferiore di circa 10 mm.

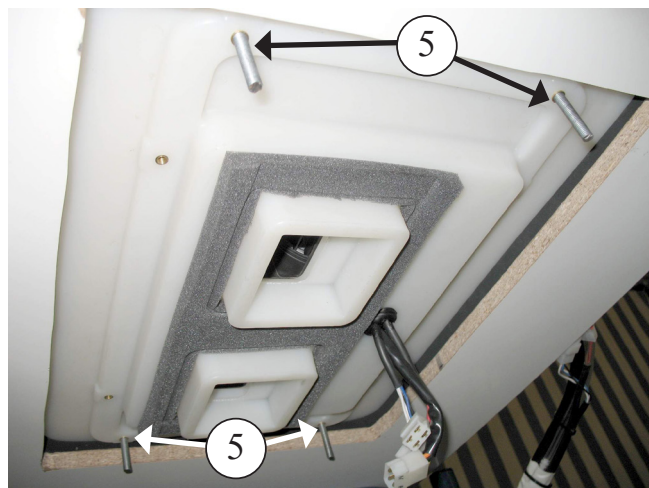
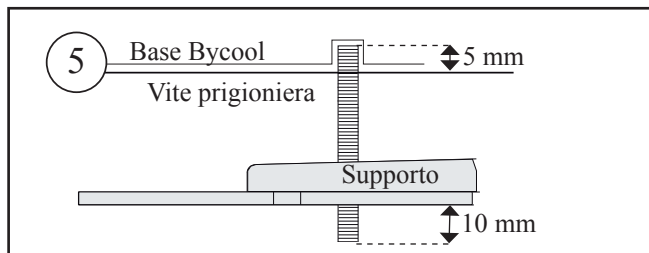

6 Collocare (1) rondella Ø 7 di gomma, (1) rondella piana Ø 8 larga, (2) dado M8 e (1) rondella piana Ø 8 larga, in ognuna delle viti prigioniera precedenti.

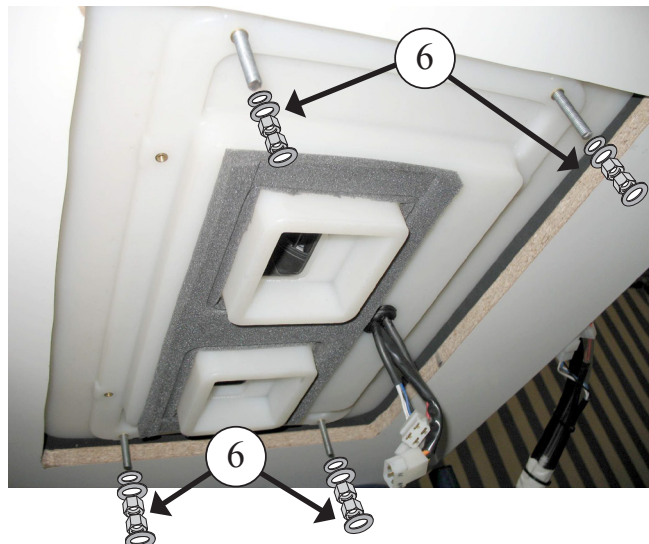

6a

Collocare (2) supporti di fissaggio, con (1) rondella e (1) dado autobloccante M8, **senza stringere**.



7

Filettare 10 mm (4) viti prigioniere M6 X 55 o 80, dove indicato, a seconda dell'altezza (A) dello schema del punto 9.

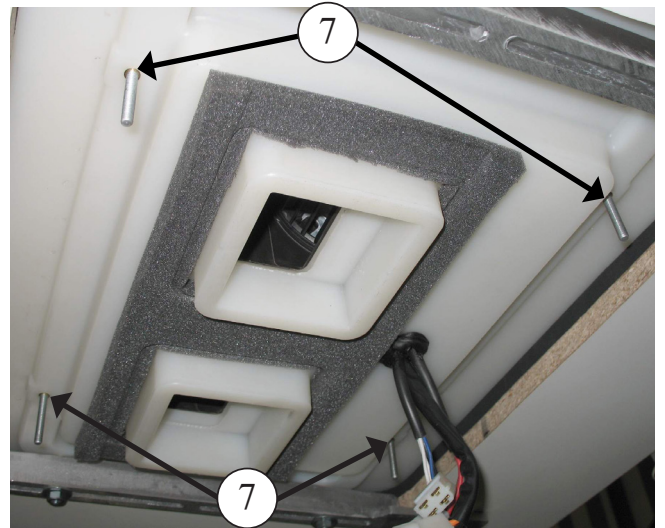

8

Collocare (1) rondella Ø6 di gomma, (1) rondella piana Ø6 larga e (1) dado M6, su ciascuna delle viti prigioniere M6. **Stringere il dado.**



8a

Collocare (1) dado M6 **senza stringere** in ogni vite prigioniera.

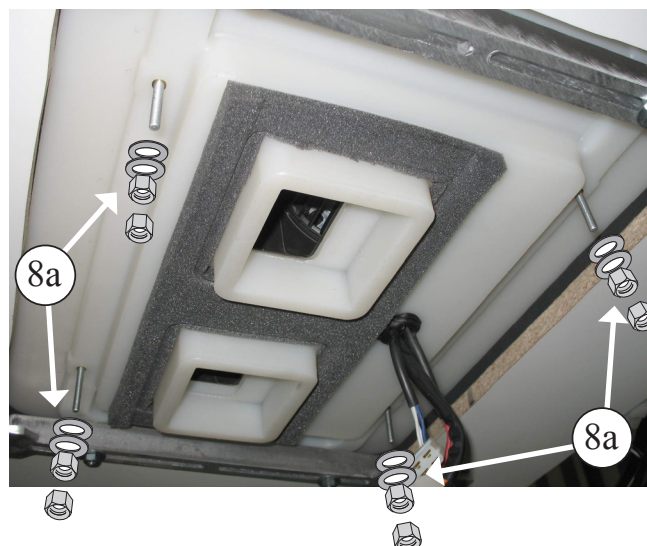
**8b**

Incollare i canalizzatori sul pannello interno di distribuzione dell'aria utilizzando LOCTITE superglue 3 o simile, per agevolare il montaggio dell'insieme e assicurare i flussi d'aria fredda dalle bocchette.

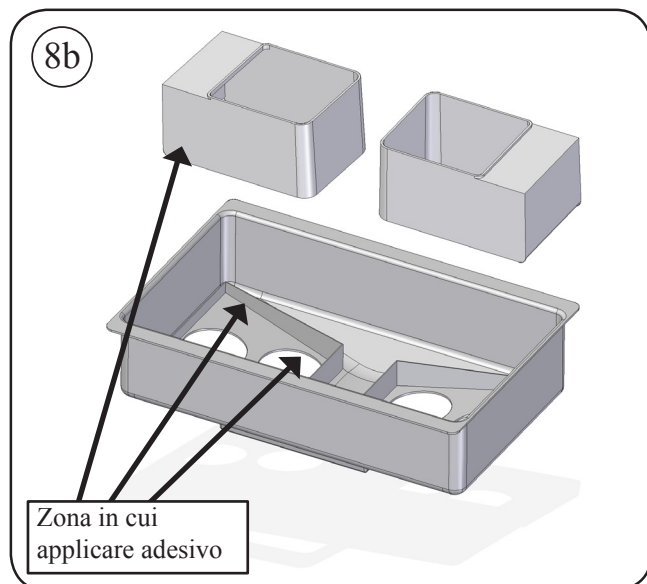
**8c**

Collegare le (2) scatole a 4 vie e (1) a 2 vie del pannello interno di distribuzione dell'aria a quelle del **Bycool**.

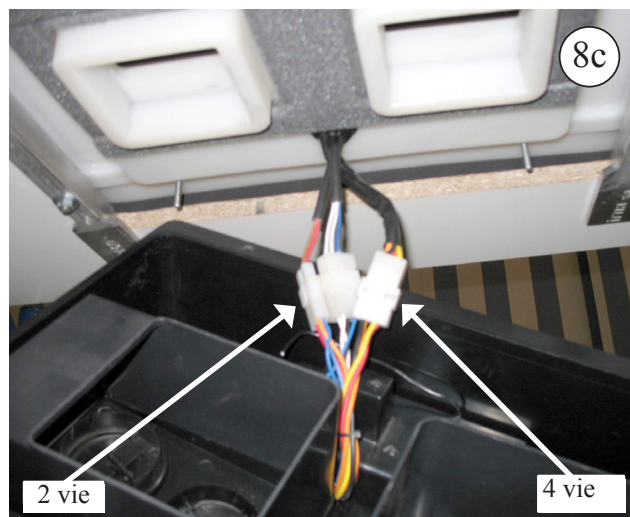

9 Posizionare il pannello interno di distribuzione dell'aria sulle viti prigioniera anteriori con (1) rondella M6 a testa larga e (1) dado M6 su ogni vite prigioniera. Stringere i dadi finché i canalizzatori non sono a battuta sulla gommapiuma superiore dell'impianto.
Importante: I canalizzatori devono essere collocati contro la gommapiuma per evitare fughe d'aria.

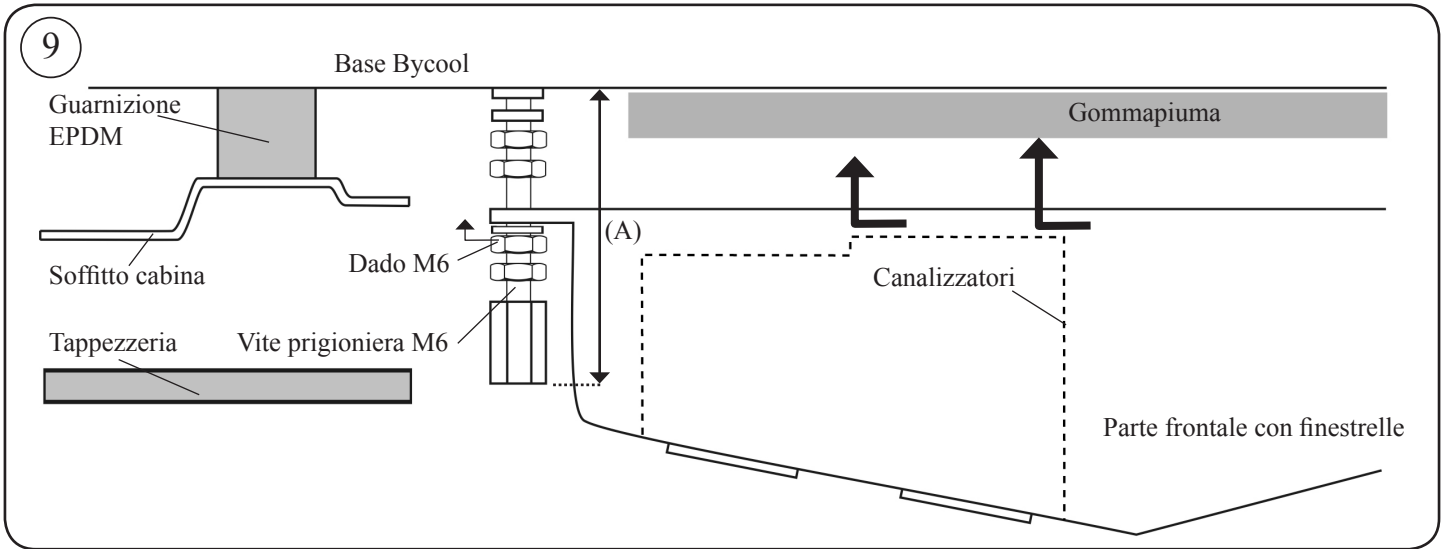

10 Stringere il dado del punto 6a fino a battuta con la parte superiore del pannello interno di distribuzione dell'aria.

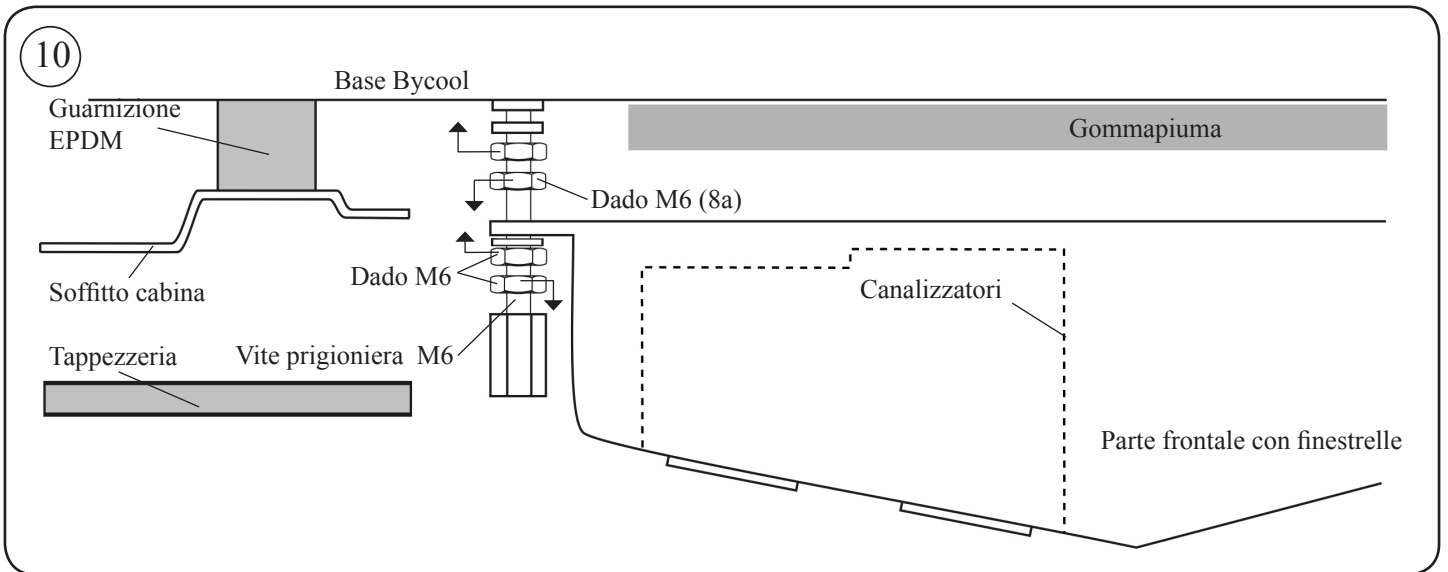

11 Collocare la consolle e centrare il dispositivo nel posto più conveniente del soffitto della cabina. Una volta centrato togliere la consolle.

12

Fissare i supporti di fissaggio stringendo i dadi fino al serraggio della guarnizione di EPDM esterna del dispositivo tra 3 e 6 mm.

Importante: Per evitare possibili infiltrazioni d'acqua all'interno della cabina bisogna garantire il serraggio della guarnizione EPDM con la base del Bycool come indicato nello schema.



Verificare la compressione della guarnizione EPDM usando un flessometro sui quattro angoli.

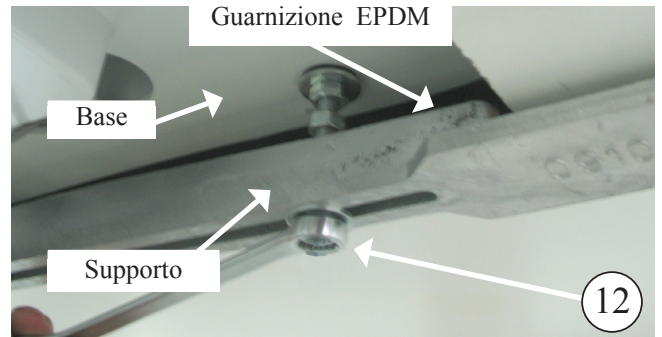
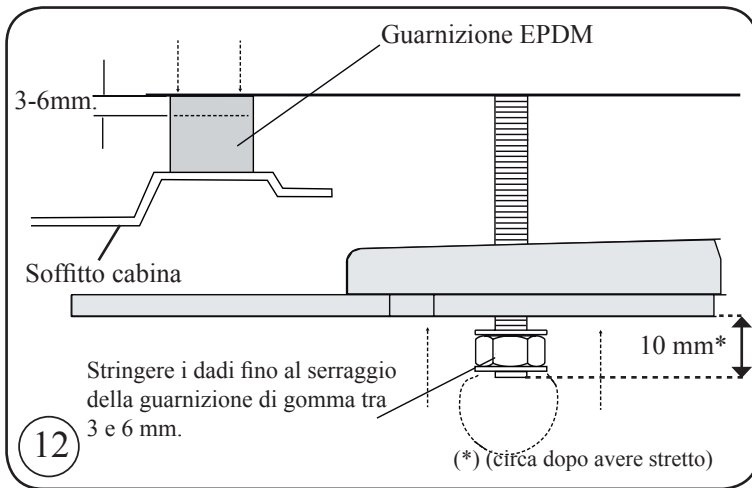

13

Stringere (4) dadi M8 al supporto e (4) alla base del Bycool.

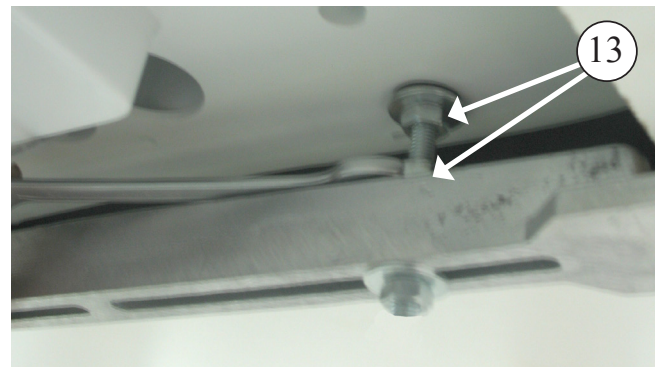

14

Inserire il dado M6 (A) dopo il dado di fissaggio del pannello interno di distribuzione dell'aria in ogni vite prigioniera. Inserire i perni esagonali M6 avvitandoli fino a lasciarli sporgere 1 mm al di sopra della tappezzeria. Svitare i dadi M6 (A) di questo punto fino a battuta con i perni esagonali e stringerli contro gli stessi.

14

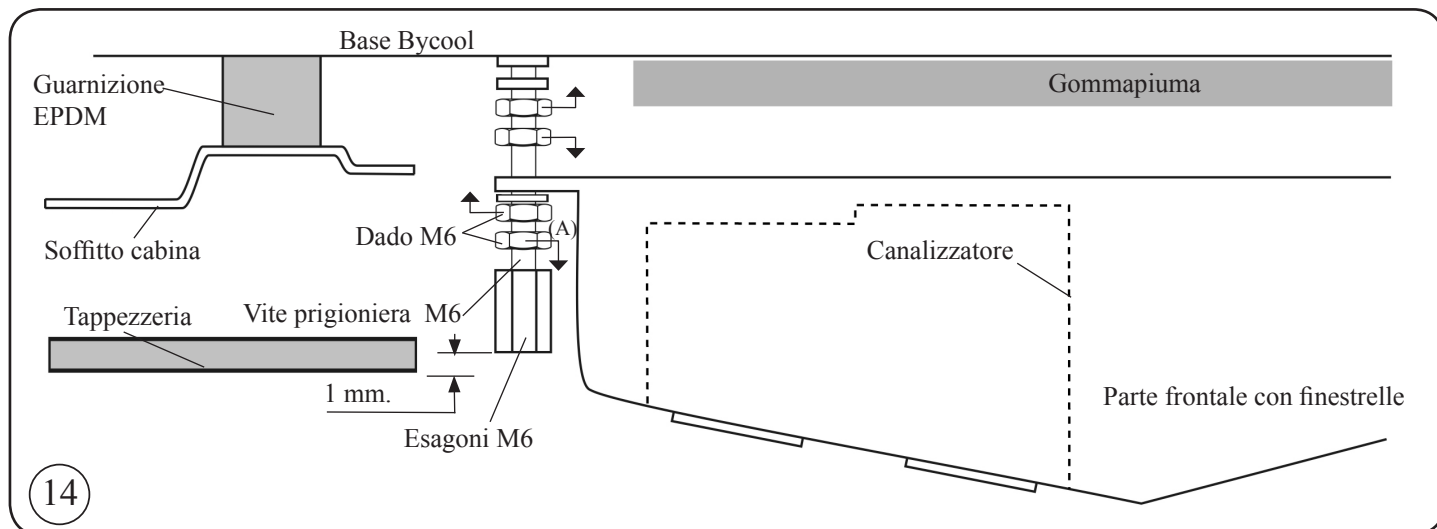
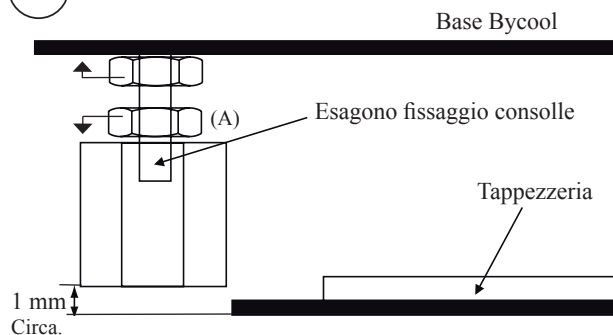

14

15

Collocare la consolle con (4) viti M6/100x15 a brugola.

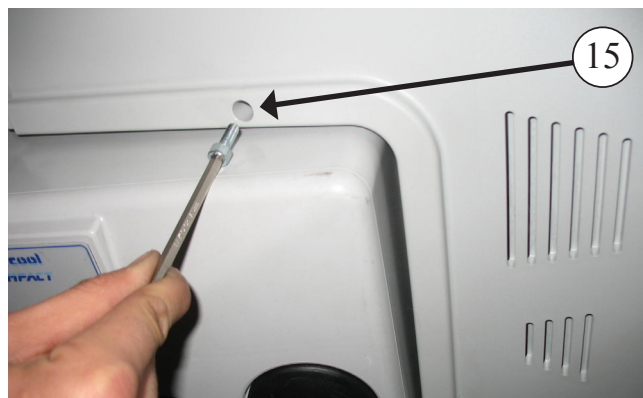

15a

Coprire le (4) viti M6/100x15 a brugola con gli elementi decorativi rotondi M6 in plastica.

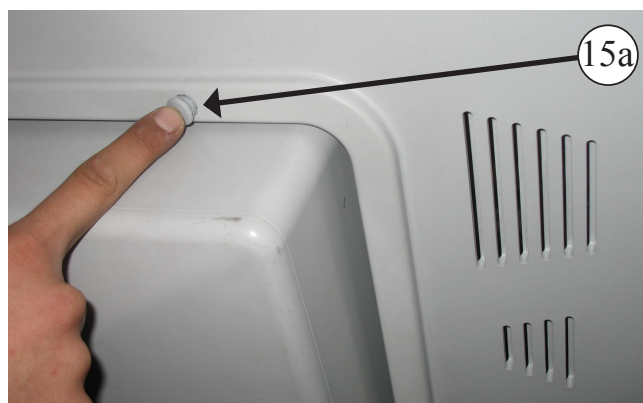

Vista esplosa fino al fissaggio dei supporti

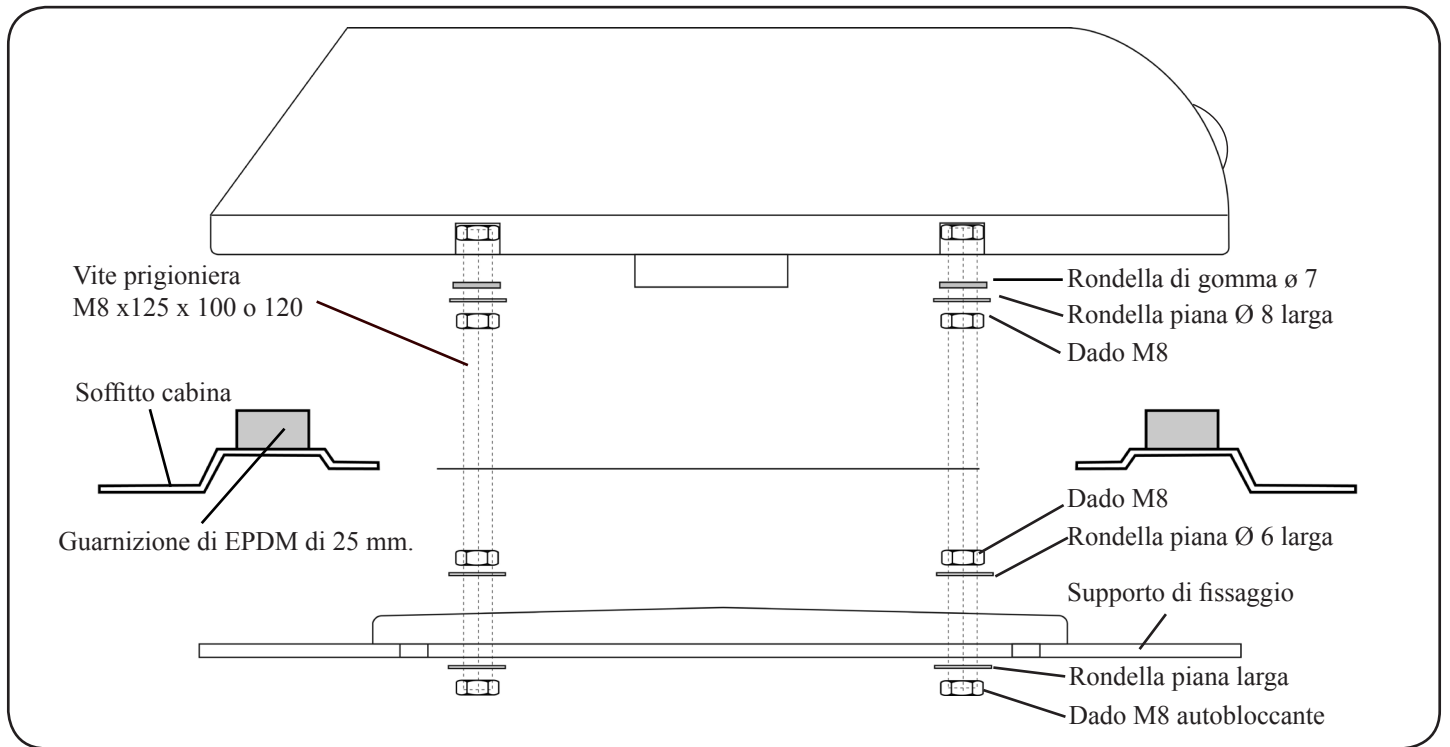

Vista esplosa fino al fissaggio delle consolle

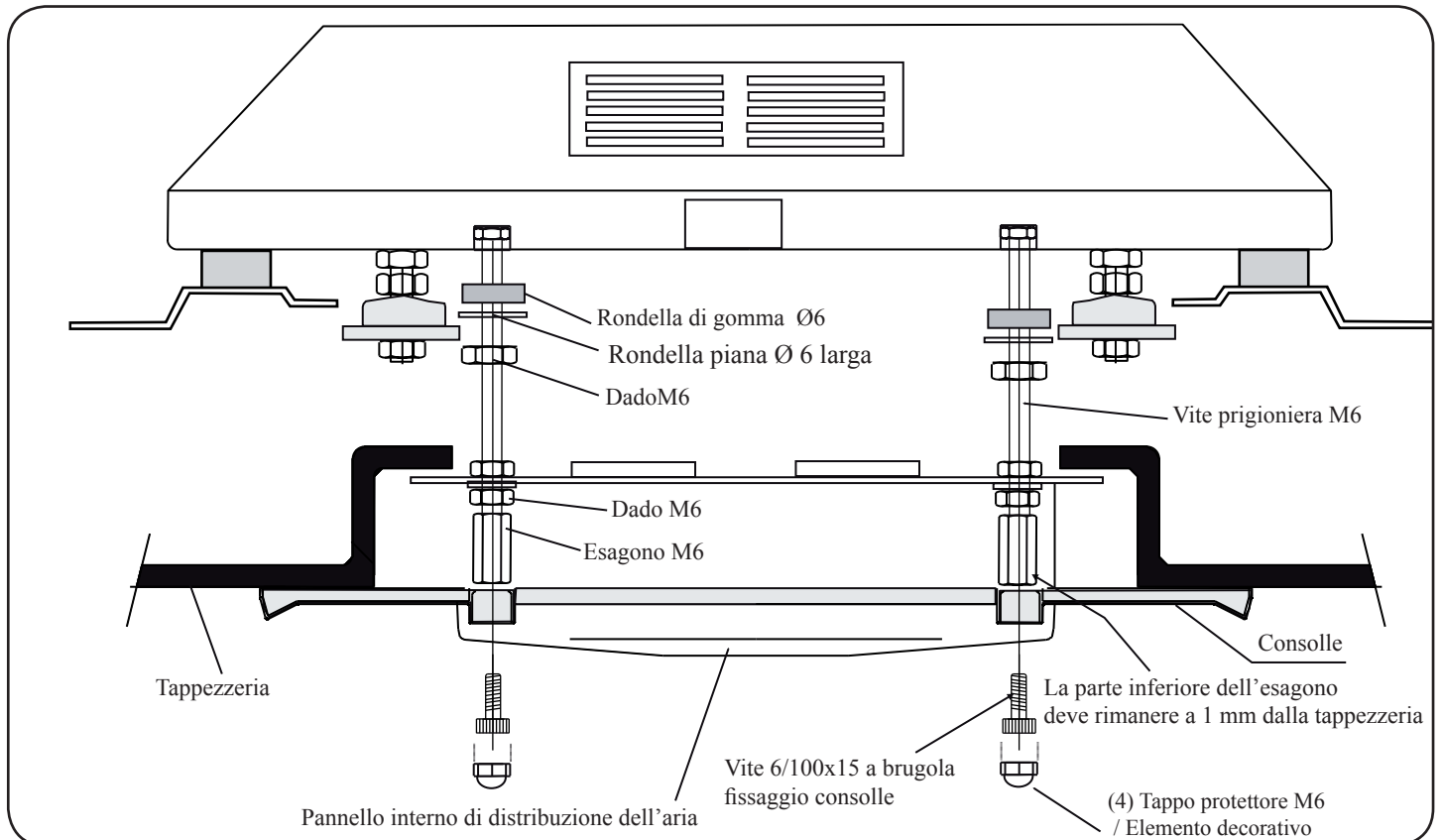

- 16** Collegare casse cablaggi e tubi, dalla parte posteriore del Bycool come viene indicato.

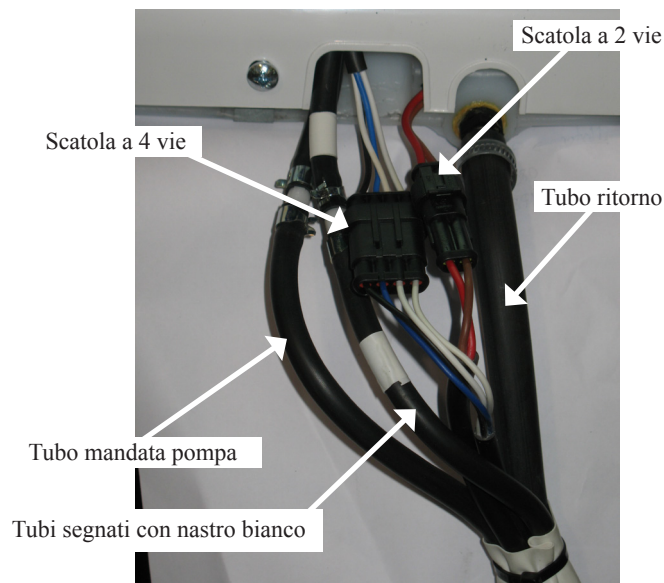

- 17** Collocare il supporto del serbatoio nella parte bassa più adeguata della zona posteriore della cabina. Segnare e forare $\varnothing 9$ in cabina considerando la posizione verticale del supporto. Minimo (6) fori di fissaggio.



- 18** Collocare dadi rivetto M6 e fissare il supporto con viti 6/100x30.
(*) - nei casi in cui non poggi su una parte liscia, collocare un separatore di 10 mm e una vite 6/100 x 40.

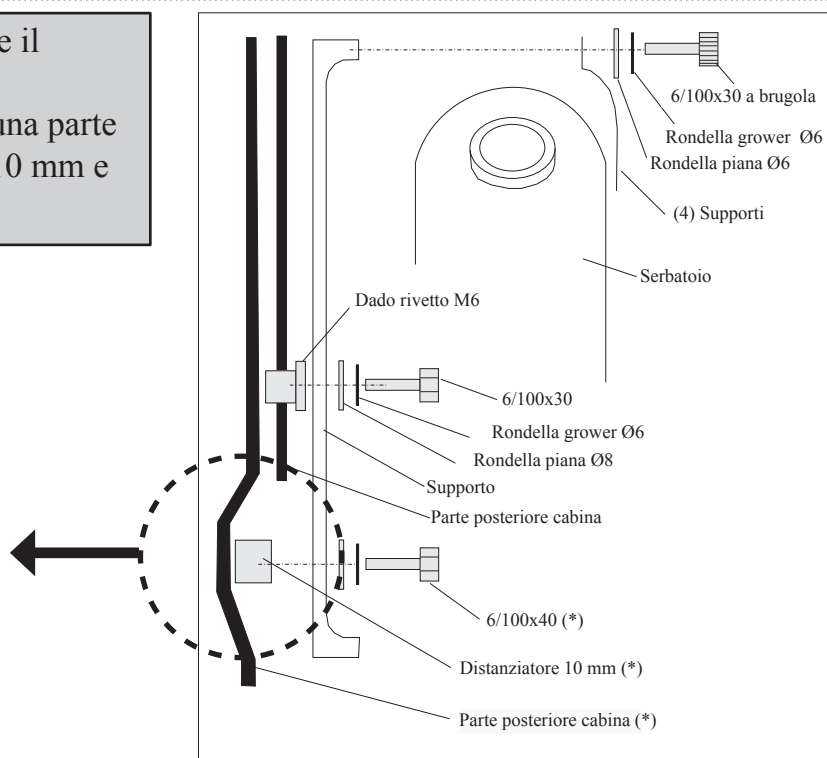

- 19** Fissare l'insieme della pompa al serbatoio con (2) viti da lamiera 5.4x19 mm.



- 20** Quindi collegare il tubo della pompa (X) al serbatoio e fissarlo (scegliendo la posizione migliore per il tappo di riempimento, destra o sinistra, per agevolare lo stesso) con i supporti forniti. Il supporto con aggetto viene collocato nel caso in cui si monti il deposito con il tappo di riempimento (Y) sul lato sinistro.

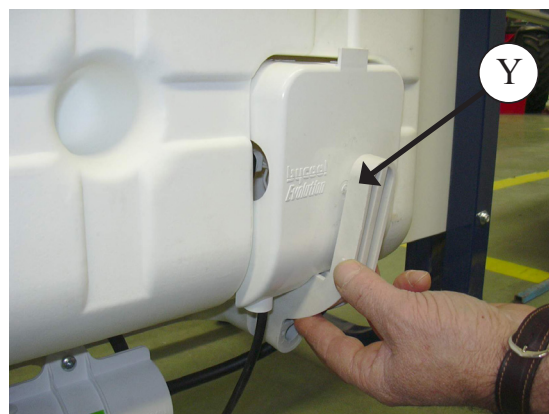
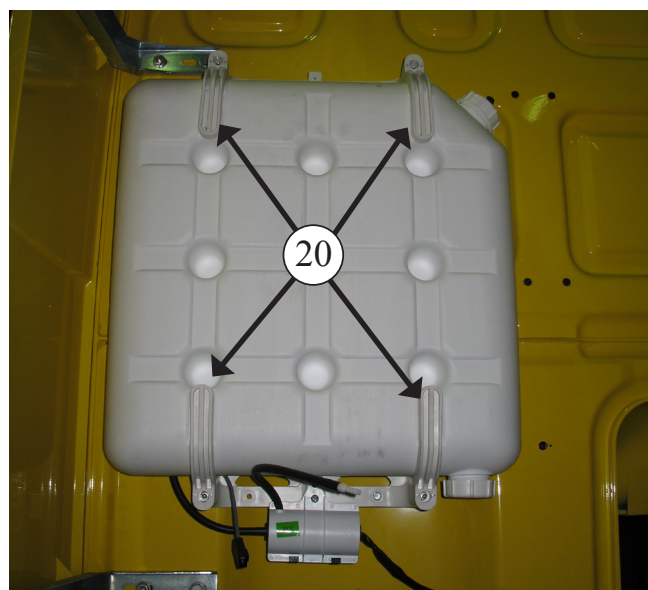

- 21** Montare filtro nel tubo con perno, inserire nel tappo e collegare al tubo di ritorno Ø18 x Ø12 (A).

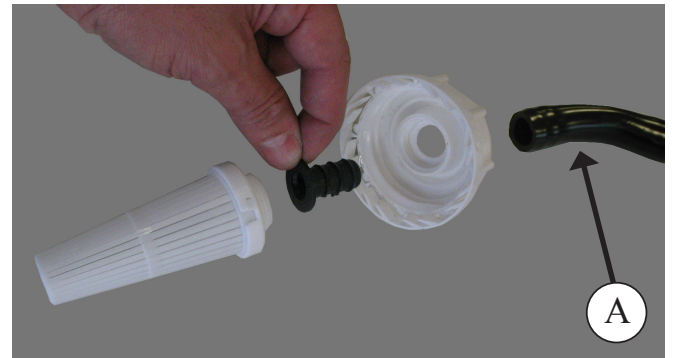

- 22** Collocare il tappo nel serbatoio, tagliare a 100 mm; intercalare "T" e collegare alla stessa un tubo di sezione inferiore, segnato con del nastro bianco e assicurarsi che il raggio della curva sia sufficiente per evitare strangolamenti.



- 23** Connettere il cablaggio con guaina alle scatole dell'evaporativo e tubo entrata acqua.

A. Collegare alla pompa il tubo di mandata che proviene dall'evaporativo.
B. Collegare cablaggio pompa e quello di livello.

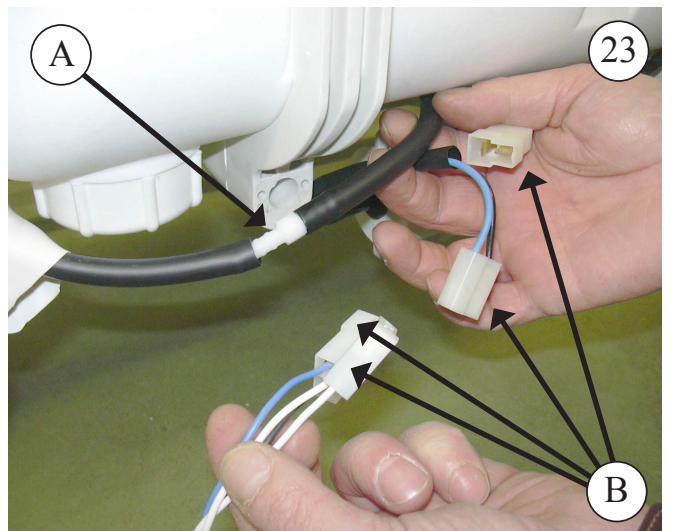

24

Collegare come indicato il cablaggio della batteria.



25

Tubo di scarico

(*) Modalità corretta di installazione, dove il tubo di scarico ha una certa inclinazione ed evita nodi e strangolamenti per agevolare la caduta dell'acqua verso il serbatoio.

(**) Modalità non corretta. Non fare così.

(***) NON TAGLIARE il cablaggio in eccesso e fissarlo (avvolto), dietro al serbatoio d'acqua.

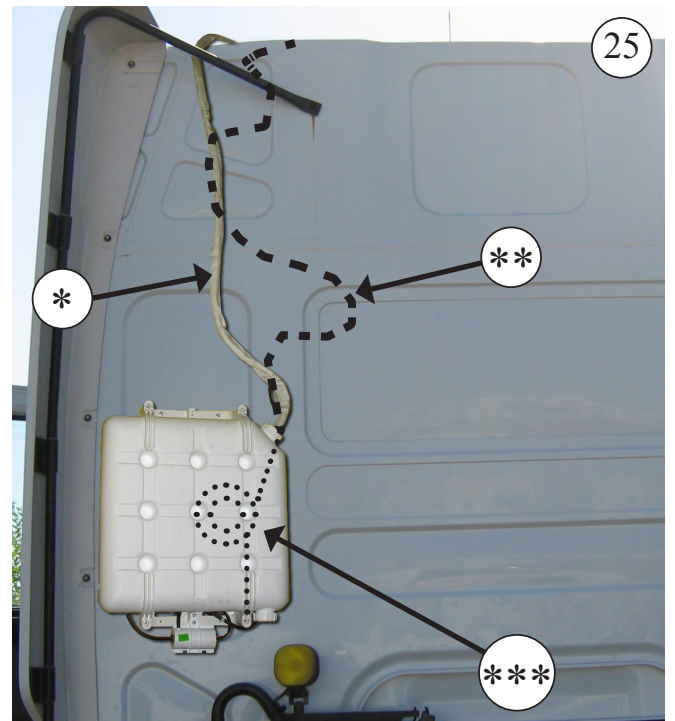

Importante:

Il condizionatore evaporativo funziona prendendo l'aria dall'esterno che viene poi inserita nella cabina. È fondamentale che quest'aria non rimanga stagnante all'interno, cosa che darebbe origine a un eccesso di umidità. Tutte le cabine dei veicoli moderni sono dotate di griglie di ricambio dell'aria, attraverso cui esce l'aria necessaria. Ad esempio per il riscaldamento.

L'installatore dovrà assicurarsi dell'esistenza di questi griglie e, nel caso in cui non esistano, dovrà installarle.

Dal canto suo, l'utente dovrà controllare periodicamente che queste griglie non siano otturate dalla sporcizia.

Istruzioni dettagliate sull'installazione del cablaggio di alimentazione



Cablaggio di alimentazione



1- Portare il cavo di alimentazione del dispositivo fino alla batteria del veicolo, incollando i supporti di plastica nella parte posteriore della cabina e fissandolo con flange; successivamente, con la cabina ribaltata, passare il cavo dalla parte inferiore della stessa, fissandolo con ghiera e viti M4; e fino alla batteria con flange; bisogna utilizzare lo stesso percorso del cablaggio originale. *(Per incollare i supporti di plastica pulire prima bene la zona)*. Quando si collega il dispositivo alla batteria, questi farà un test di tutti i suoi led e si spegnerà.

NOTA BENE: dato il complesso sistema di regolazione elettronica dell'impianto, la corrente deve essere presa direttamente dalla batteria del veicolo, non da qualsiasi altro punto che eroga ad altri accessori del veicolo, facendo attenzione a non invertire la polarità effettuando la connessione (2). Se si inverte la polarità si possono causare danni irreparabili all'elettronica, che la garanzia non copre.

IMPORTANTE: Per l'avviamento consultare il Manuale dell'Utente.

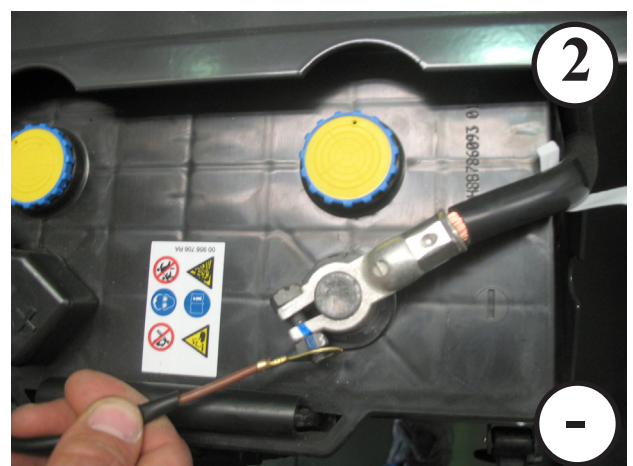

Schema Elettrico

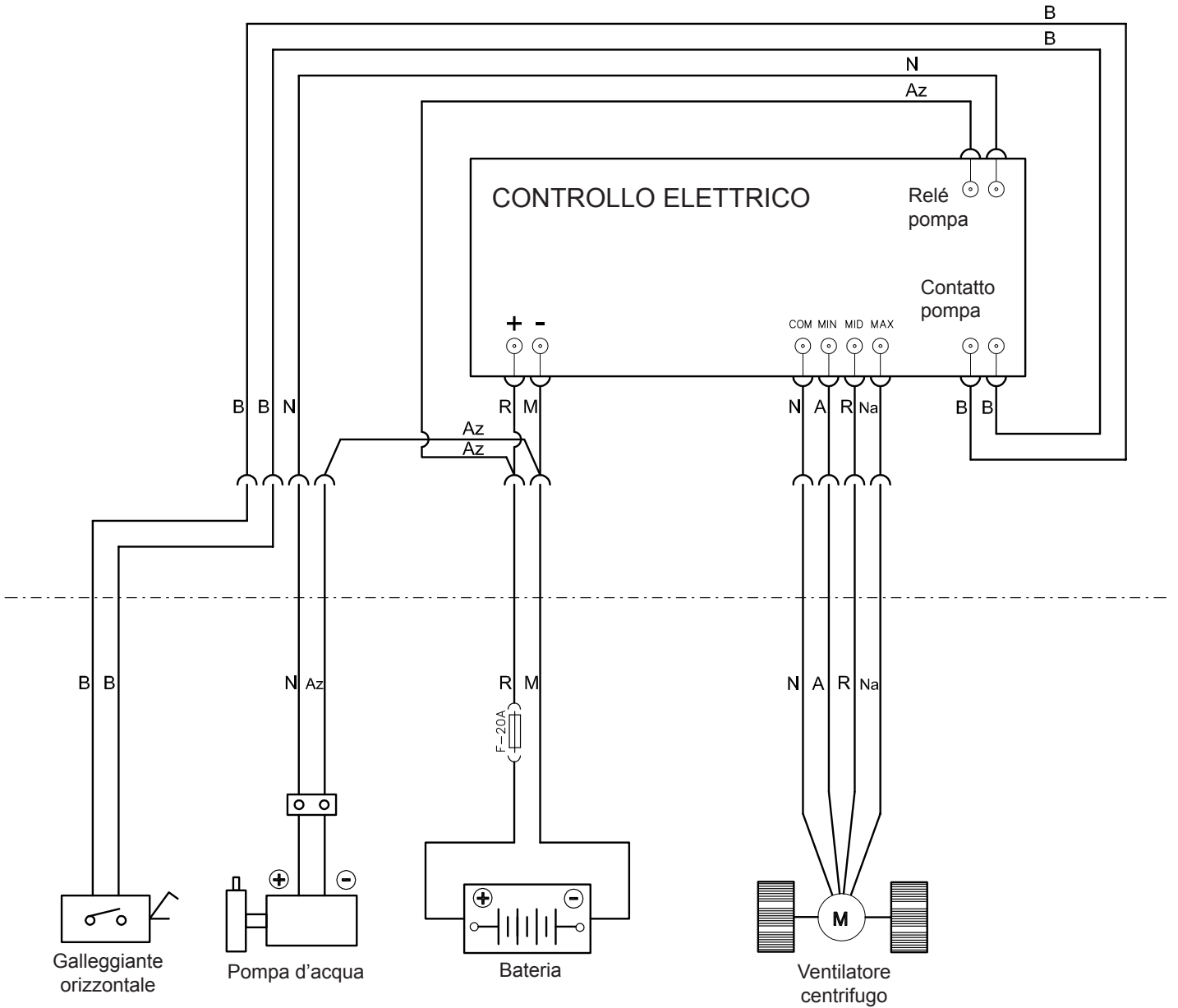

POMPA D'ACQUA GALLEGGIANTE

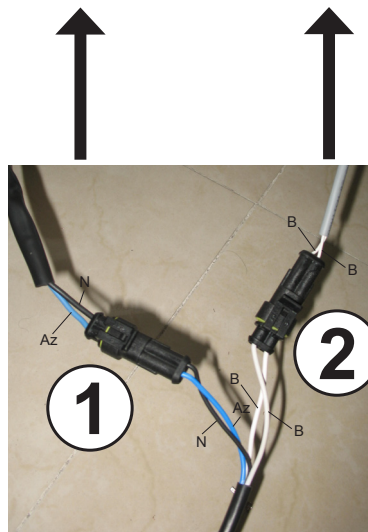

COLORI

A	Giallo
Az	Blu
B	Bianco
G	Grigio
Na	Arancione
N	Nero
R	Rosso
Ro	Rosa
V	Verde
Vi	Viola
M	Marrone
Mo	Viola

Ed:	30/01/2008
Md:	30/08/2019

C



Francisco Alonso, 6
28806 Alcalá de Henares, Madrid
SPAIN

Contact	Phone	Fax	E-Mail
Sales (Ventas Internacional)	+34 91 8770510	+34 91 8771158	sales@dirna.bergstrominc.com
Comercial Nacional	+34 91 8775841	+34 91 8836321	ventas@dirna.bergstrominc.com
Orders & Deliveries (Logística internacional)	+34 91 8775846	+34 91 8771158	export@dirna.bergstrominc.com
Orders & Deliveries (Logística nacional)	+34 91 8775840	+34 91 8836321	comercial@dirna.bergstrominc.com
Technical Assistance (Internacional)	+49 511 86679681	+49 511 86679710	technicalassistance@dirna.bergstrominc.com
Technical Assistance (Nacional)	+34 91 8775845	+34 91 883 6321	oblanco@dirna.bergstrominc.com

www.dirna.com

	ATENCIÓN:	Dirna Bergstrom se reserva el derecho de efectuar modificaciones en cualquier momento de los datos contenidos en esta publicación, por razones técnicas o comerciales.
	NOTE:	<i>For technical and commercial reasons, Dirna Bergstrom reserves the right to change the data contained in this brochure.</i>
	ATTENTION:	Dirna Bergstrom se réserve le droit d'effectuer à tout moment des modifications des données reprises sur cette publication, pour des raisons techniques ou commerciales.
	HIWEIS:	<i>Dirna Bergstrom behält sich vor, aus technischen oder kaufmännischen Gründen jederzeit Änderungen der Angaben dieser Veröffentlichung vorzunehmen.</i>
	ATTENZIONE:	Dirna Bergstrom si riserva il diritto di effettuare modifiche in qualsiasi momento ai dati contenuti in questa pubblicazione, per motivi tecnici o commerciali.