

bycool!
green line

COMPACT 1.4

**MAN TGX / TGA
Cab. XLX / XXL**



Instrucciones de Montaje

Mounting Instructions

Instructions de Montage

Montageanweisungen

Istruzioni di Montaggio

ES Spanish

EN English

FR French

GE German

IT Italian

Recomendaciones Para el montaje

- Antes de iniciar el montaje leer las instrucciones y seguirlas durante el proceso de instalación.
- Usar las herramientas adecuadas para cada operación.

Electricidad

- Desconectar la llave de contacto.
- Desconectar la batería antes de empezar el montaje.
- Asegurar el conexionado de los componentes eléctricos, verificando su correcto encaje.

Atención

Si durante el montaje el equipo se inclina, se deberá esperar un mínimo de 60 minutos desde que el equipo quede en posición horizontal antes de ponerlo en funcionamiento.

Atención

Al instalar el equipo de aire acondicionado en el techo se debe proteger la parte superior de la cabina con un paño ó manta protectora para evitar posibles arañazos. Al instalar **Compact** en el techo hay que tener en cuenta que, normalmente, las cabinas que vienen provistas de escotilla, tienen una estructura suficiente para soportar el peso del equipo. Sin embargo, cuando no ocurra así y sea necesario realizar corte en el techo ó incluso si en el caso de llevar escotilla el material no es lo suficientemente resistente (caso de techo de fibra, plástico, etc...) es el instalador el que debe decidir, **bajo su responsabilidad**, sobre la necesidad de reforzar el techo para evitar posibles deformaciones, roturas, entradas de agua, etc... habilitando los medios para que esto no ocurra.

Herramientas

Juego de Llaves Torx

Juego de Llaves Allen

Llave fija 10, 13, 14







Tijeras

Flexómetro

Documentación incluida

Instrucciones de montaje	220.AA3.3080
Manual del usuario	220.AA6.0170
Diagnos de averías	220.AA6.0013
Piezas suministradas	220.RE0.0121
Garantía	220.AA1.0017

Advertencias

-  El personal instalador debe poseer una formación suficiente en Aire Acondicionado de vehículos.
-  **dirna Bergstrom, s.l.** queda exenta de responsabilidad si se producen averías que procedan de una inadecuada manipulación ó instalación del equipo, ó por modificaciones y sustituciones efectuadas sin nuestra expresa autorización por escrito.
-  **Equipo precargado con gas refrigerante. (No manipular el circuito de gas refrigerante).**
-  Véase **procedimiento de garantía** del producto incluido en **Diagnos de Averías**.
-  Véase **Manual de Usuario** del equipo para el correcto funcionamiento del mando a distancia y del panel de control.
-  Al finalizar la instalación se debe entregar al usuario: **Manual del Usuario, Garantía y Diagnos de averías**.

 Antes de empezar con el montaje, montar rejilla entrada aire delantera.



 Para vehículos **TGX cabina XLX con spoiler** las modificaciones a realizar en el mismo deben ser autorizadas por el cliente. Por lo que **dirna Bergstrom se exime de toda la responsabilidad** por la modificación del spoiler. En el caso de estar autorizadas las modificaciones que se deben realizar en el spoiler, se debe desmontar éste antes de comenzar la instalación.

1 Desmontar tapa escotilla, los elementos de fijación y entregar éstos al cliente.



2 Quitar los residuos sobrantes adheridas al techo antes de pegar la junta EPDM.

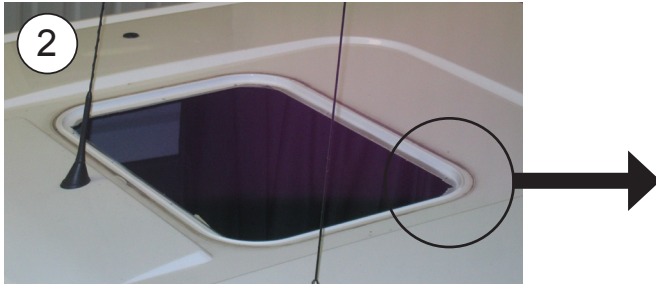

3 Pegue la junta EPDM 25x15 alrededor del resalte del hueco de escotilla (*mirar el detalle para cortar los bordes finales de unión de la junta*).

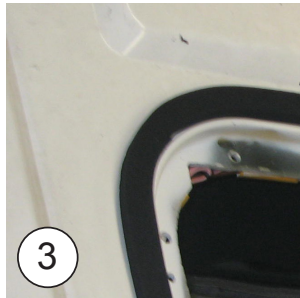

COMO CORTAR LA JUNTA EPDM PARA EVITAR FILTRACIÓN DE AGUA EN LA CABINA

- A- Pegar la junta, manteniendo 100 mm de papel protector por cada lado.
- B- Quitar los dos piezas de papel.
- C- Pegue presionado ambos finales.

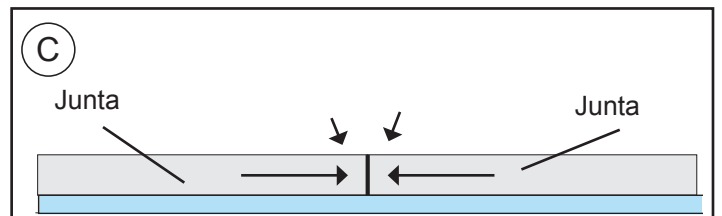
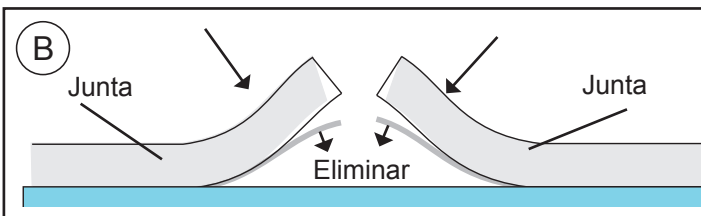
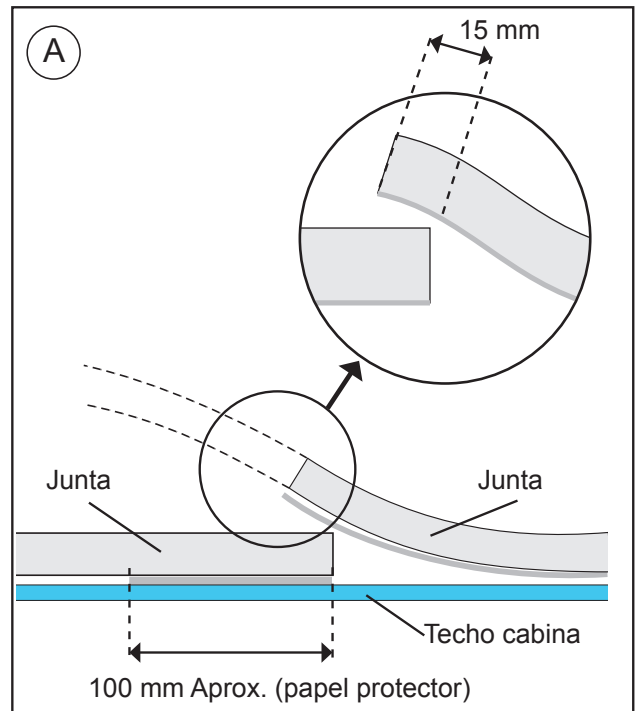

4 Roscar 10 mm (4) espárragos M8x85 en base Compact, sobre ellos introducir (1) arandela de goma, (1) plana y (1) tuerca. Apretar contra la base.

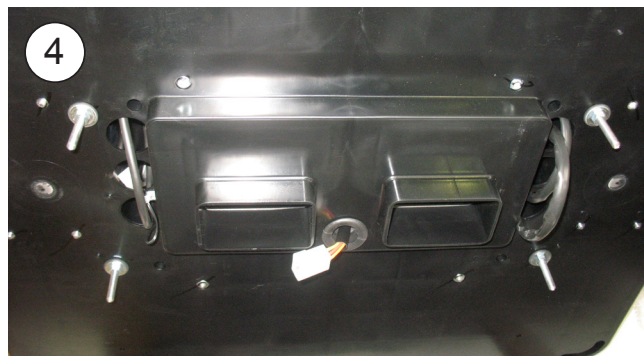
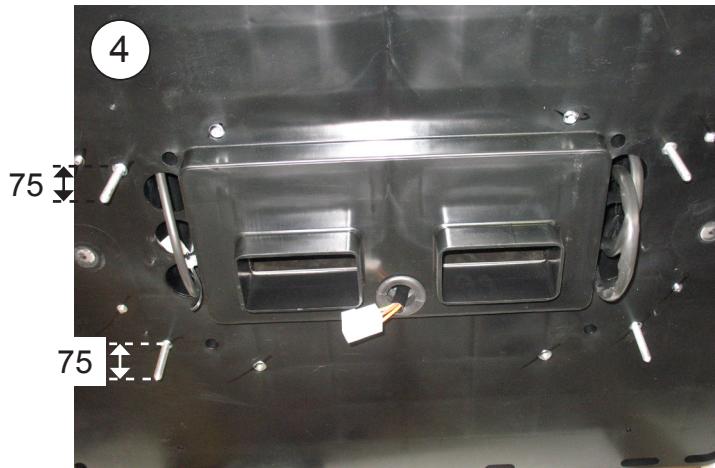

TGA / TGX cabina modelo XLX con spoiler

 **Atención:** Para instalación de este modelo es necesario efectuar modificaciones en el spoiler, las cuales deben ser autorizadas por el cliente. **dirna Bergstrom se exime de toda responsabilidad para la modificación del spoiler.**

5 Pegar junta EPDM 30x25 en chapa escotilla como se indica.
ATENCIÓN: Limpiar previamente la chapa para asegurar la adhesión de la junta EPDM.

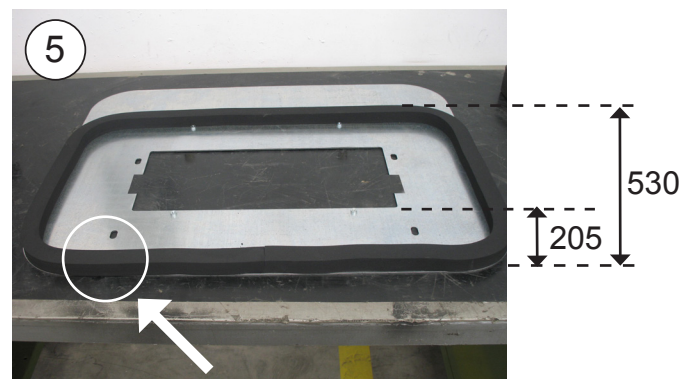

Colocación parte trasera del equipo colocar al borde

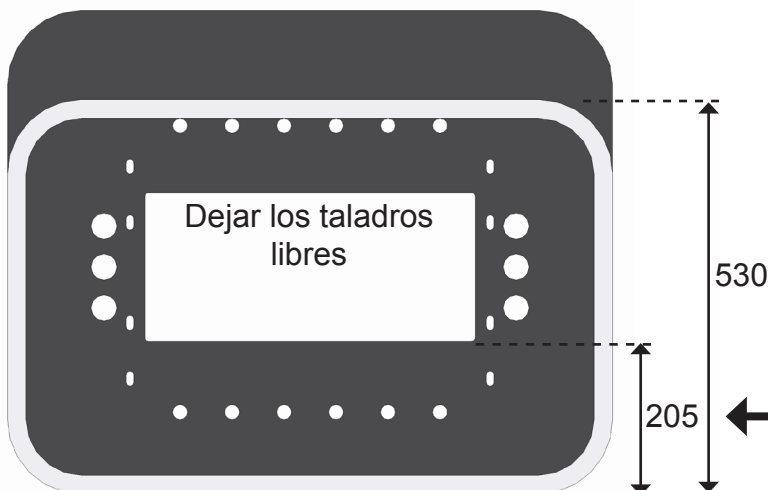

 Atención a la medida

TGA / TGX cabina modelo XLX/XXL sin spoiler

5a Pegar junta EPDM 30x25 como se indica.
Atención: Limpiar previamente la chapa para asegurar la adhesión de la junta EPDM.

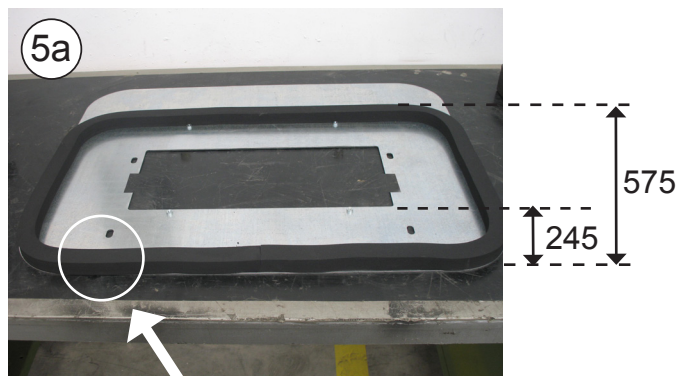
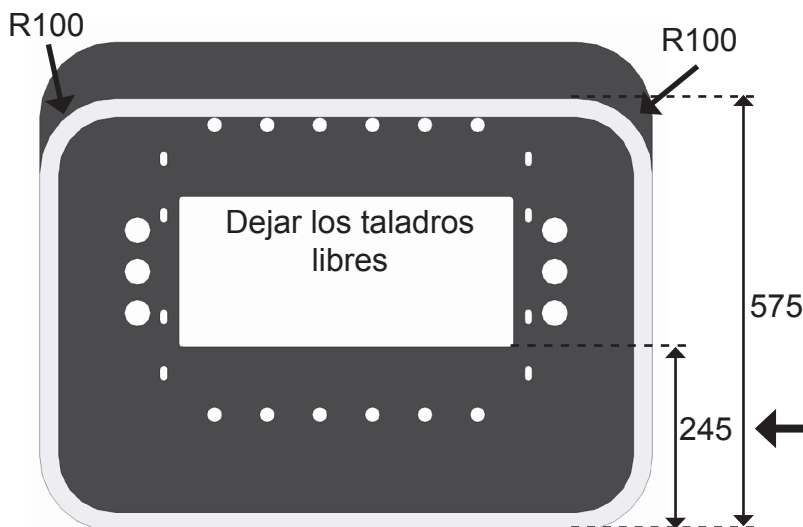

Colocación parte trasera del equipo colocar al borde

⚠ Atención a la medida

6 Colocar equipo sobre chapa escotilla, introduciendo espárragos en los taladros con corredera de la chapa indicada en 6a y 6b.
¡ATENCIÓN! Al colocar el equipo encima del hueco escotilla revisar que las salidas de desagüe no queden obstruidas por la junta EPDM.



TGA / TGX cabina modelo XLX con spoiler



Atención: Para instalación de este modelo es necesario efectuar modificaciones en el spoiler, las cuales deben ser autorizadas por el cliente. **dirna Bergstrom se exime de toda responsabilidad para la modificación del spoiler.**

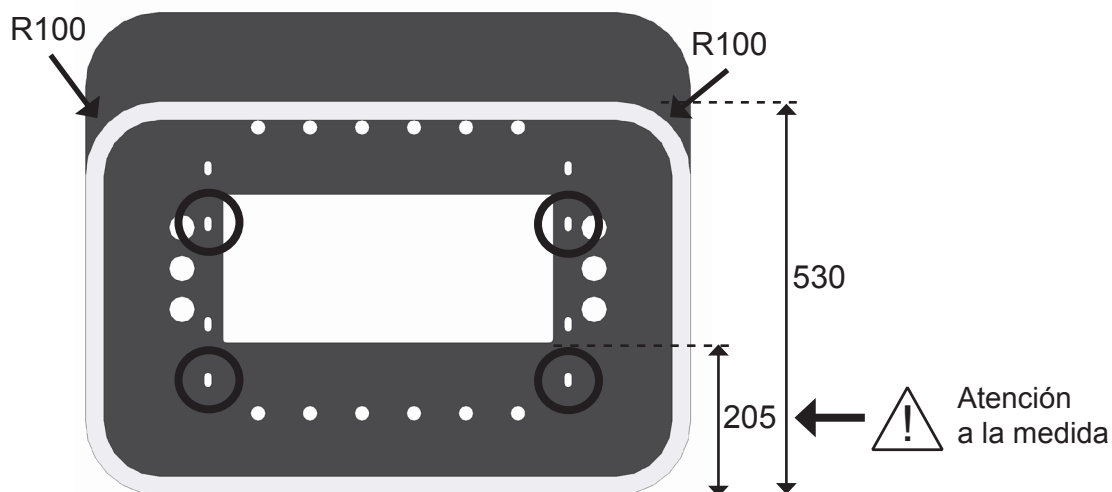

TGA / TGX cabina modelo XLX/XXL sin spoiler

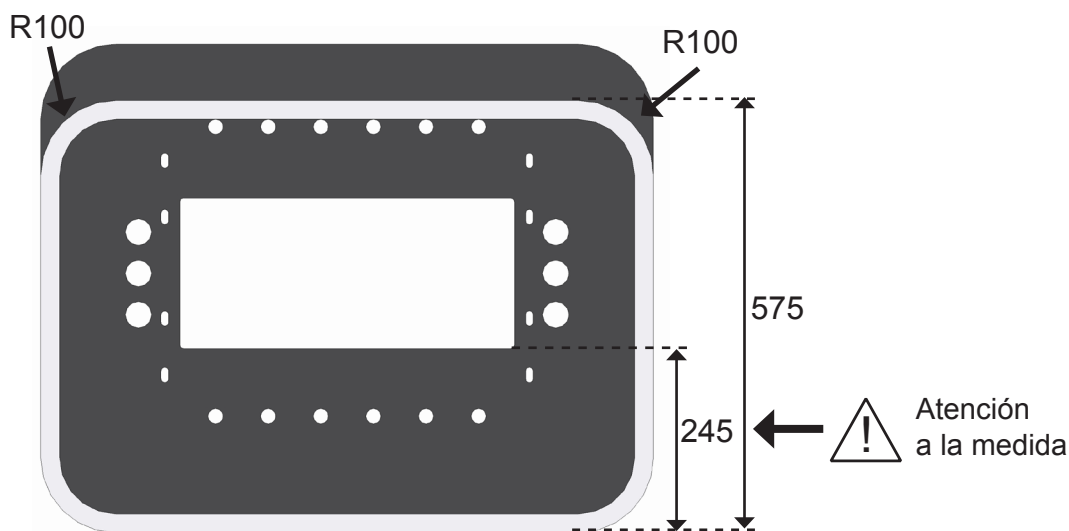

- 7** Introducir (1) arandela plana y (1) tuerca en cada espárrago y apretar hasta hacer tope la chapa con las tuercas de fijación de los espárragos a la base.

8 Posicionar equipo con chapa sobre hueco de escotilla del vehículo por la parte delantera. La chapa escotilla debe quedar a haces de la junta EPDM.



9 Por la parte interior centrar lateralmente el equipo en hueco escotilla.
 ⚠ **Importante:** En el caso de no venir la junta (A) pegada en la base, retirar papel protector de la misma y pegarla como se indica.

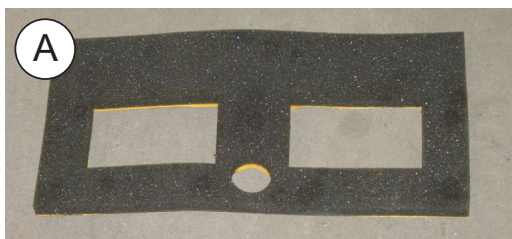
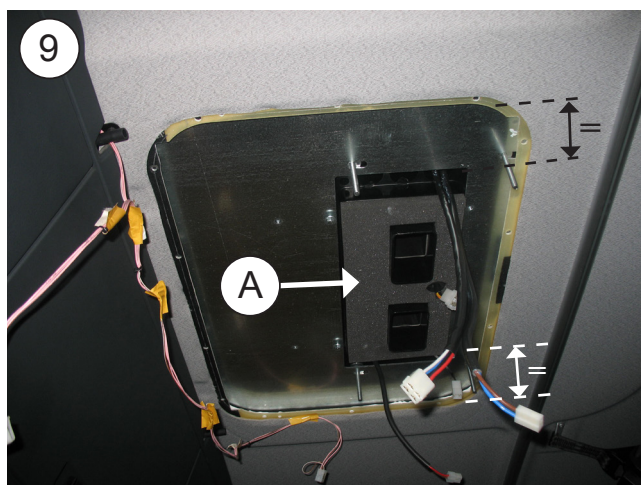

10 Pegar canalizadores en el panel interior de distribución de aire.
 ⚠ **Importante:** En el caso de incorporar el equipo canalizadores (B), éstos se desechan, no son válidos para este equipo.

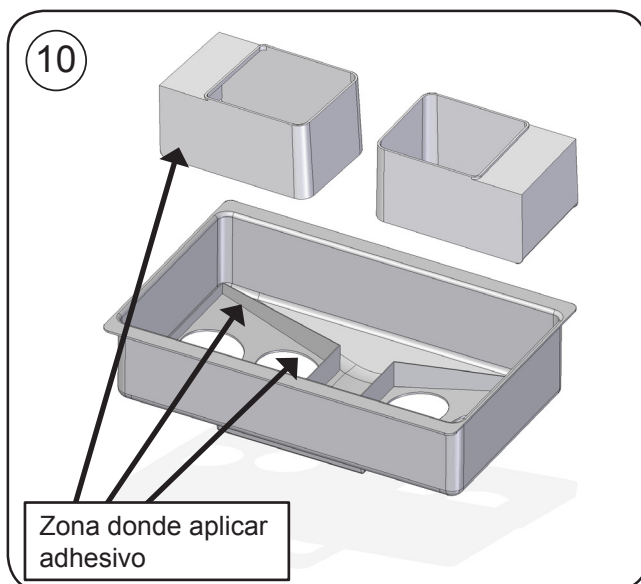

11 Entre equipo y panel interior de distribución de aire, conectar las (2) cajas de 4 vías; las (2) cajas de 2 vías y conectar cableado de alimentación en caja de 2 vías en "T".

ATENCIÓN: Es muy importante no invertir los colores de la caja de 2 vías del ventilador del condensador (caja con cables R y N).



12 Introducir panel interior de distribución de aire en espárragos existentes más próximos a las guanteras delanteras sobre la chapa fijándole con hexágono M6x25 (Atención que no interfieran cableados entre canalizadores y equipo).

ATENCIÓN: Colocar panel interior de distribución de aire de forma que los canalizadores hagan ajuste con la junta de la base del equipo.

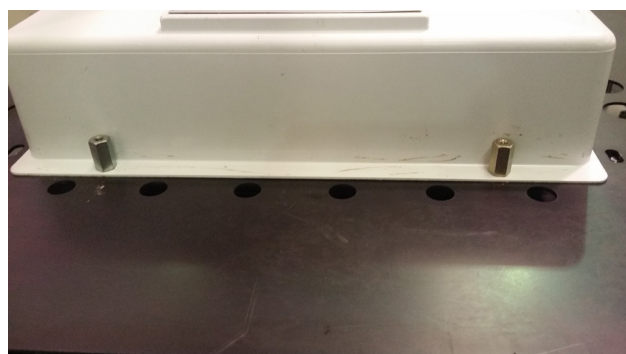

12a Presentar consola y centrar equipo de forma que quede donde estaba ubicada la consola original.



13 Colocar soportes sobre espárragos M8, fijar con arandelas Ø8 ala ancha y tuerca M8 autoblocante apretándolas hasta que el soporte haga contacto en la parte central con la chapa.

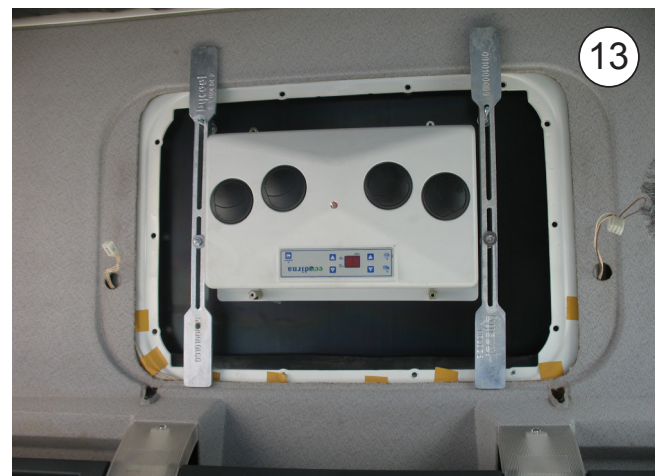

14 Colocar consola con (4) tornillos 6/100x15 allen. **⚠ ATENCIÓN, sacar cableados originales del alumbrado interior a través de los huecos de las consolas.**



15 Conectar y montar luces originales en la consola.



16 Cubrir los (4) tornillos M6/100x15 allen con los embellecedores redondos de M6 de plástico.



17 Conectar y fijar cableado c/soportes de plástico y bridas a techo cabina (limpiar bien la zona antes).



Vista Explosionada hasta la fijación de los soportes

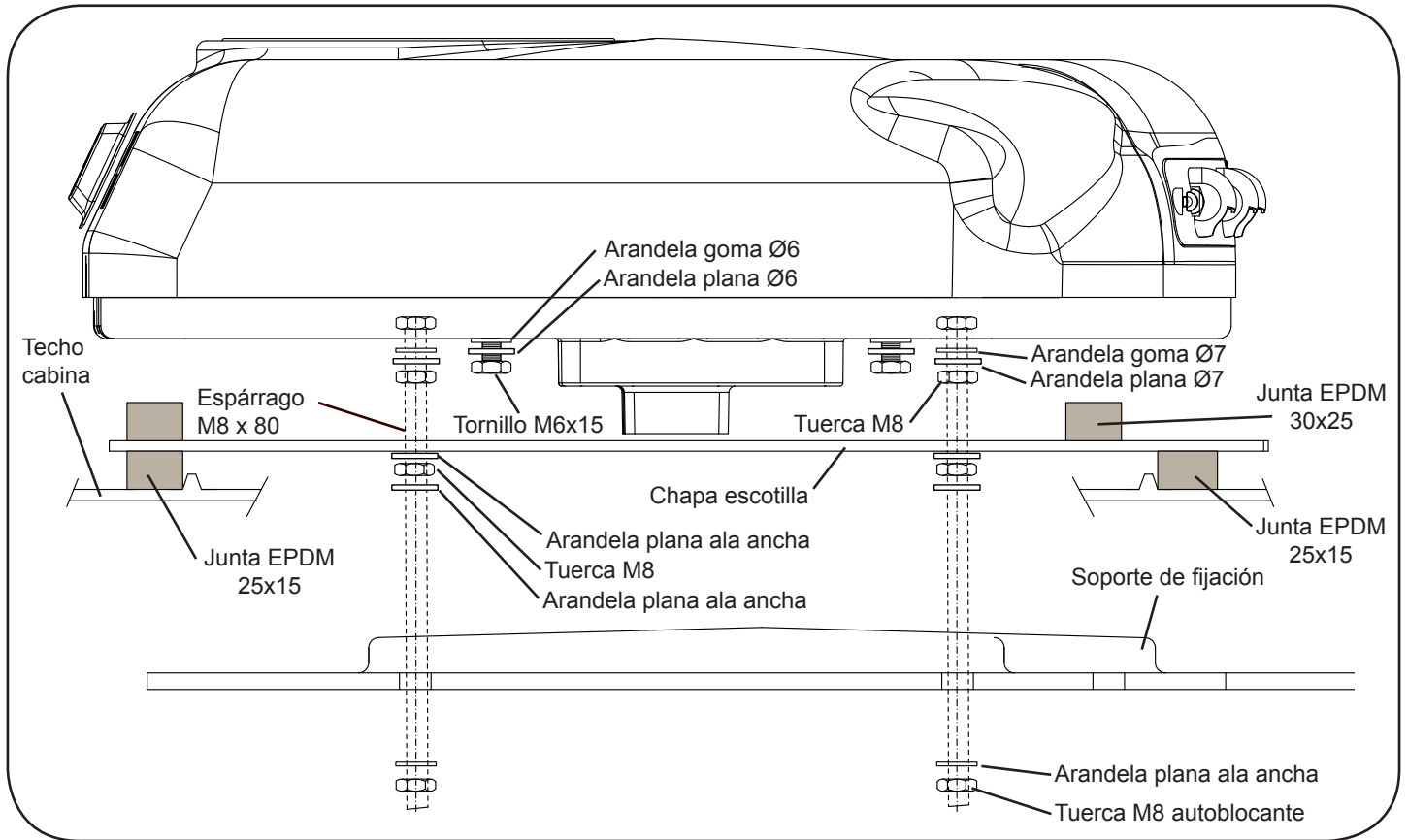

Vista explosionada hasta la fijación de las consolas

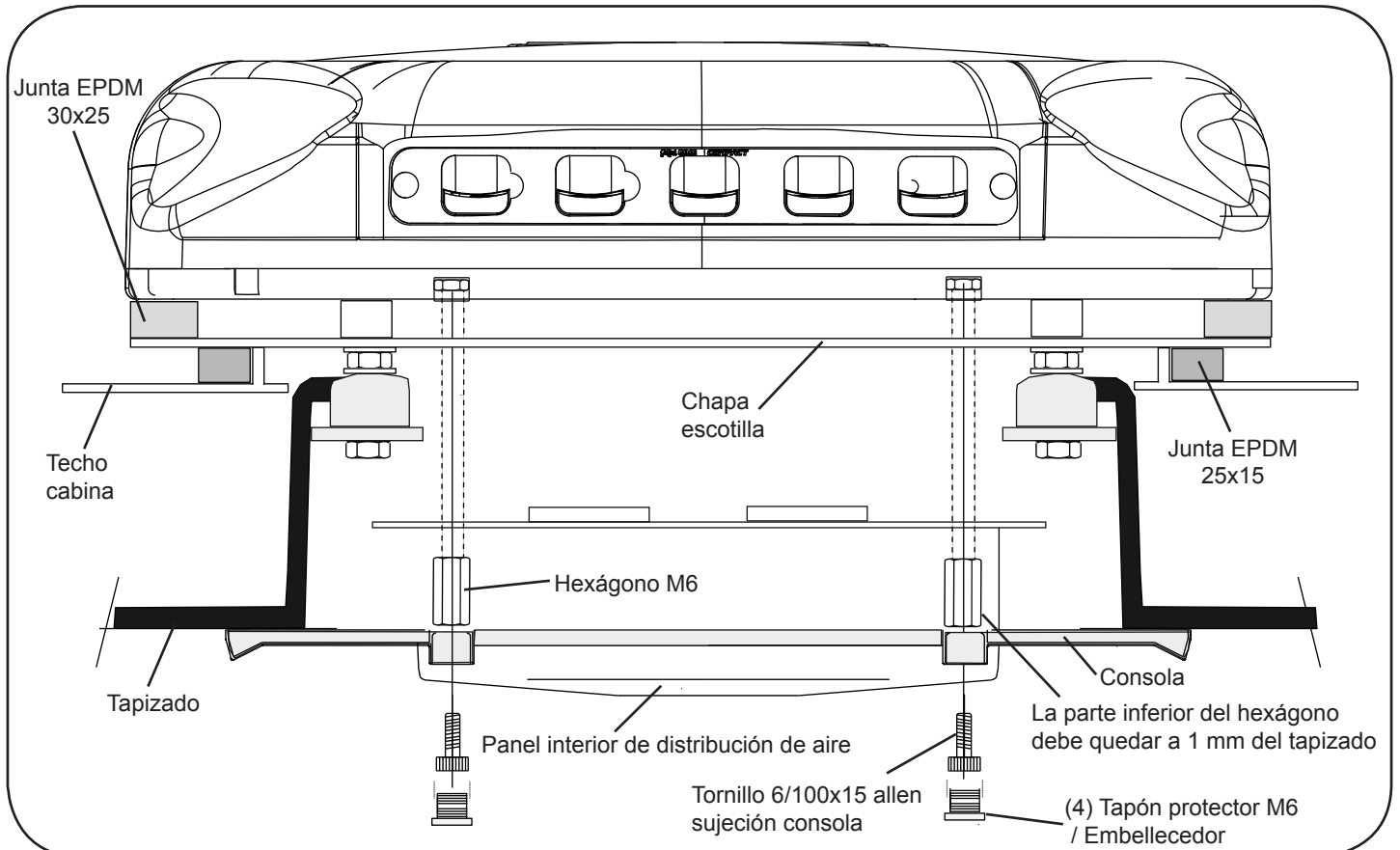

Instrucciones detalladas sobre la instalación del cableado de alimentación



Cableado de alimentación



1- Llevar el cable de alimentación del equipo hasta la batería del vehículo, pegando los soportes de plástico en la parte posterior de la cabina y fijándolo con bridas; después con la cabina abatida pasar el cable por la parte inferior de la misma sujetándolo con abrazaderas y tornillos M4; y hasta la batería con bridas; se debe utilizar el mismo paso del cableado original. *(Para pegar los soportes de plástico limpiar bien la zona antes)*. Al conectar el equipo a la batería éste hará un test en todos sus leds, aparecerá en el display 88--bd y se apagará.

⚠ IMPORTANTE: Debido al complejo sistema de regulación electrónica del equipo, la toma de corriente debe realizarse directamente a la batería del vehículo o punto autorizado, no a cualquier otro punto que dé servicio a otros accesorios del vehículo teniendo la precaución de no invertir la polaridad al realizar la conexión.

⚠ IMPORTANTE: Para la puesta en marcha consultar el Manual del Usuario.

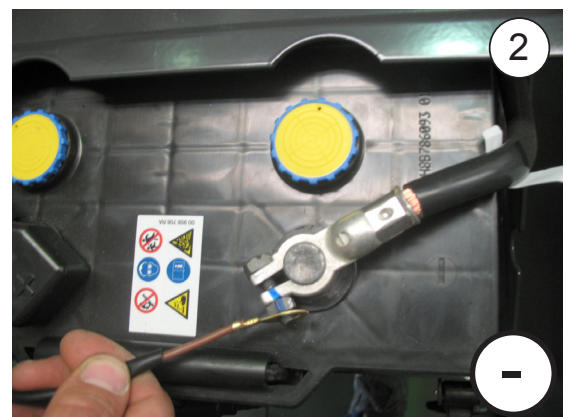

**Para cabinas XLX con spoiler
Modificaciones a realizar en el spoiler
en caso de autorización del cliente**

- 1 Marcar medidas indicadas, proteger con cinta de carrocerero para no dañar spoiler y efectuar corte.

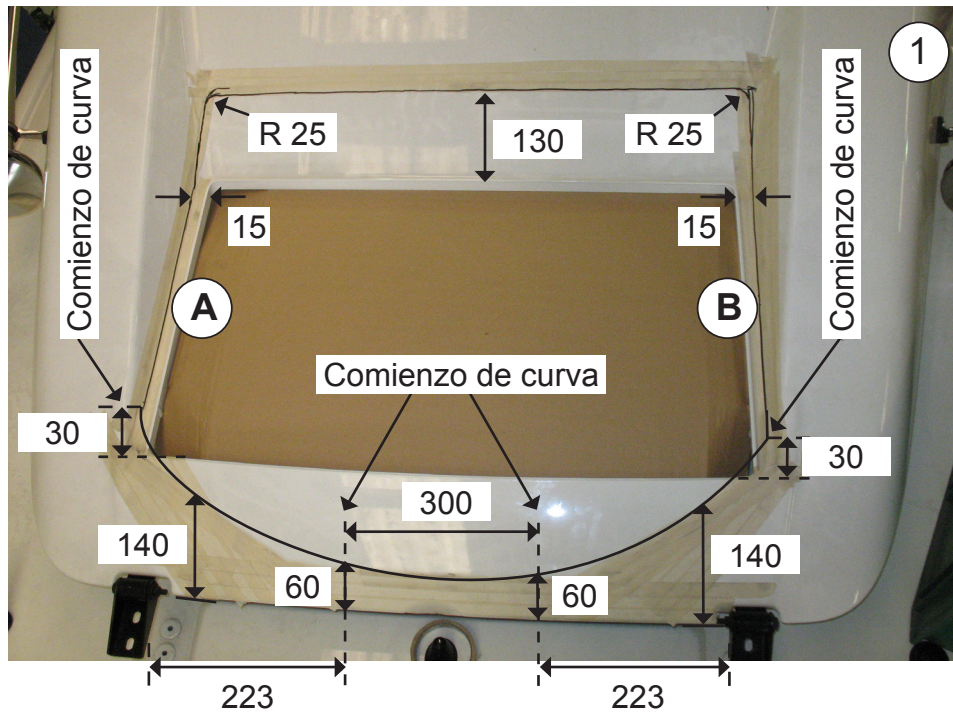

Vista por inferior spoiler

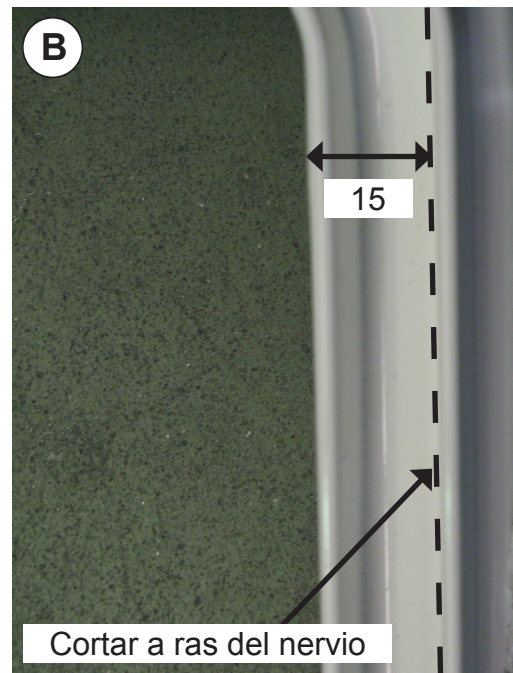
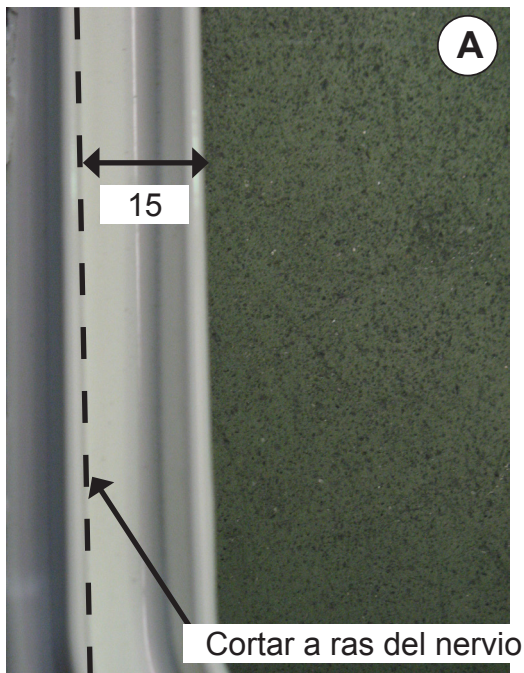

2 Montar spoiler con tornillos originales en su posición de origen.



Assembly Recommendations

- Before starting assembly, please read instructions and follow them during installation process.
- Use the adequate tools for each operation.

Electricity

- Disconnect ignition key.
- Disconnect battery before starting assembly.
- Make sure electric components are securely connected, checking their correct fitting.

Warning

If the unit slants during assembly, wait for at least 60 minutes with the unit in horizontal position before starting it up.

Warning

When installing air conditioning equipment on roof, the upper cabin part must be protected with a cloth or a protective blanket to avoid possible scratches. When installing **Compact** on roof, take into account that, normally, cabins equipped with a hatch have a strong enough structure to hold equipment weight. However, if it is not the case and it is necessary to carry out a cut in the roof or, although it has a hatch, the material is not resistant enough (*if roof is made of fibre, plastic, etc...*), it is the installer who will have to decide, under his responsibility, if it is necessary to reinforce the roof to avoid possible deformations, breaks, water entries, etc., habilitating the means required to stop it from occurring.

Tools

Torx wrenches set

Allen wrenches set

Open-jawed spanner 10, 13, 14







Scissors

Flexo-meter

Documentation included

Mounting instructions	220.AA3.3080
User's guide	220.AA6.0170
Troubleshooting	220.AA6.0013
Included parts	220.RE0.0121
Warranty	220.AA1.0017

Warnings

-  The installing personnel must have a sufficient training in vehicles air conditioning.
-  **dirna Bergstrom, s.l.** shall not be responsible for breakdowns or damages coming from an inadequate handling or installation of the equipment or from modifications and substitutions carried out without our express and written authorisation.
-  **Equipment pre-charged with refrigerating gas. (Do not handle refrigerating gas circuit).**
-  Please see product **warranty procedure** included in **Troubleshooting**.
-  Please see equipment **User's Guide** for its correct functioning of the remote control and control panel.
-  Once installation is finished, the following documents must be handed over to the user: **User's Guide**, **Warranty** and **Troubleshooting**.

 Mount the front air input grille before starting assembly.



 In XLX cabin with spoiler TGX vehicles, the changes to be made must be authorised by the customer. In consequence, **dirna Bergstrom shall be released from any liability** deriving from modification of the spoiler. Whenever changes to the spoiler have been authorised, the spoiler must be taken down before starting installation.

1 Remove the spoiler. Dismount the hatch cover and the attachment elements, and hand them over to the customer.



2 Remove any excess on the ceiling before attaching the EPDM seal.

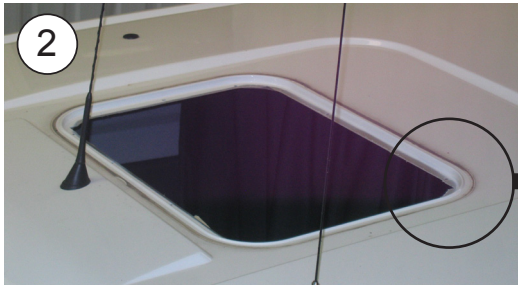

3 Attach the EPDM 25x15 seal around the hatch gap ridge (see the details to cut the ends of the seal joint).

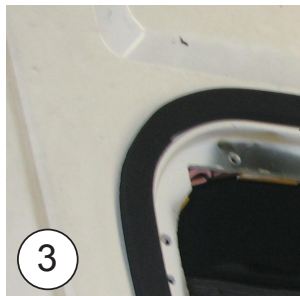

HOW TO CUT THE EPDM SEAL TO PREVENT WATER FROM DRIPPING IN THE CABIN

A- Attach the seal, keeping 100 mm of protection paper on each side.

B- Remove the two pieces of paper.

C- Attach by pressing both ends.

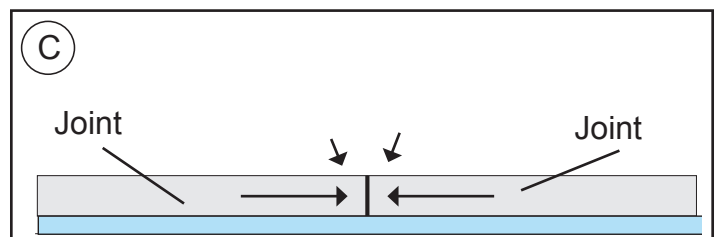
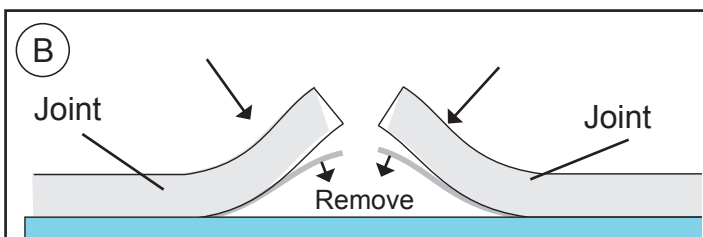
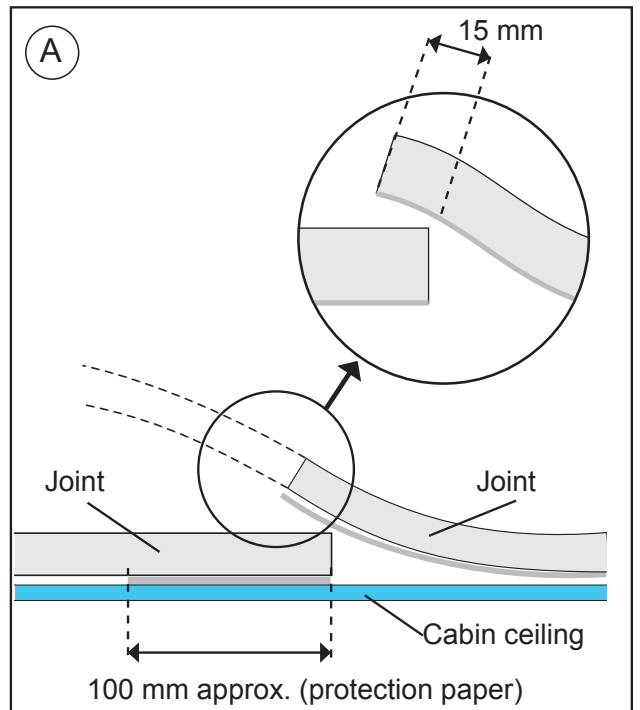

4 Screw (4) 10 mm M8x85 studs in the Compact base and place (1) Ø20xØ7x3 rubber washer, (1) Ø6 flat washer and (1) M8 nut on them. Tighten them against the base.

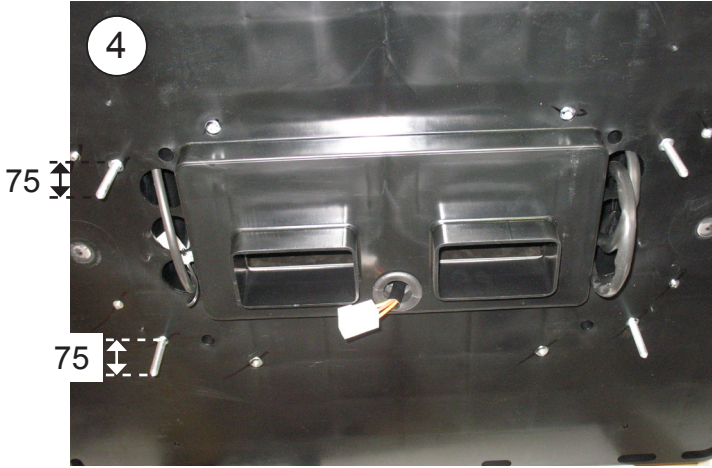
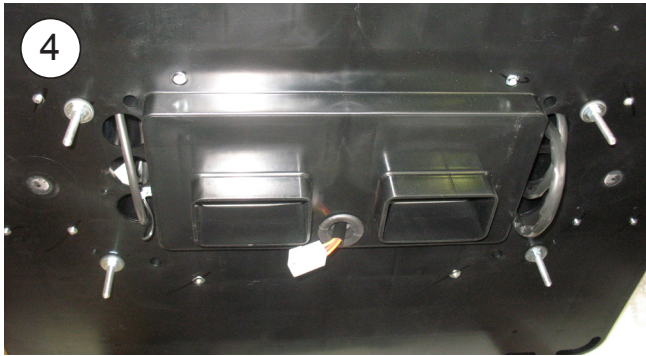

TGA / TGX cabin XLX model with spoiler

 **Caution:** The spoiler must be modified in order to install this model. All modifications must be authorised by the customer. **In consequence, dirna Bergstrom shall be released from any liability deriving from modification of the spoiler.**

5 Pegar junta EPDM 30x25 en chapa escotilla como se indica.
ATENCIÓN: Limpiar previamente la chapa para asegurar la adhesión de la junta EPDM.

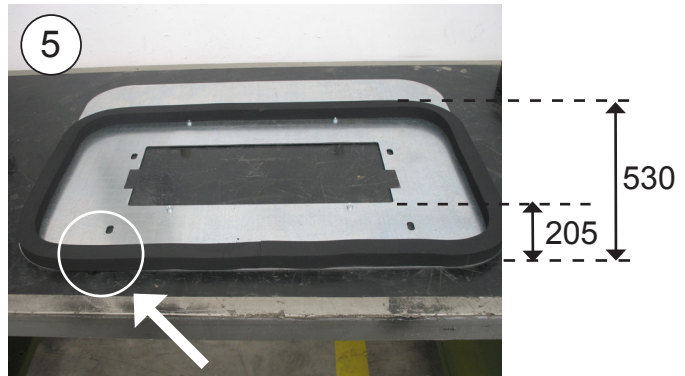

Positioning the rear part of the unit position on the edge

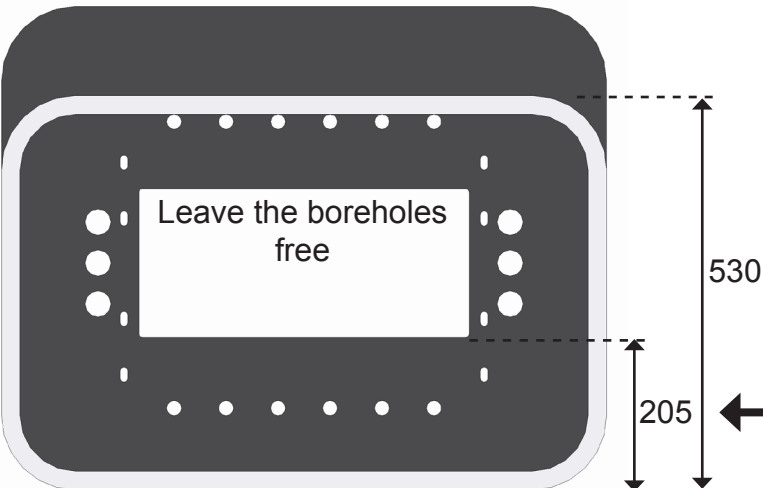

 Take care with the measurement.

TGA / TGX cabin XLX model without spoiler

5a Attach 30x25 EPDM seal as indicated.

Caution: First clean the metal to ensure the adherence of the EPDM seal.

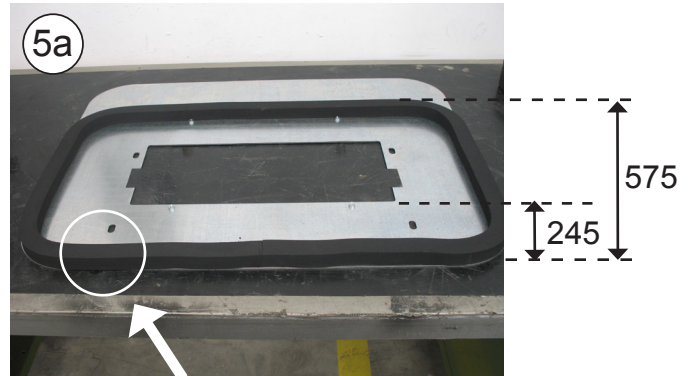
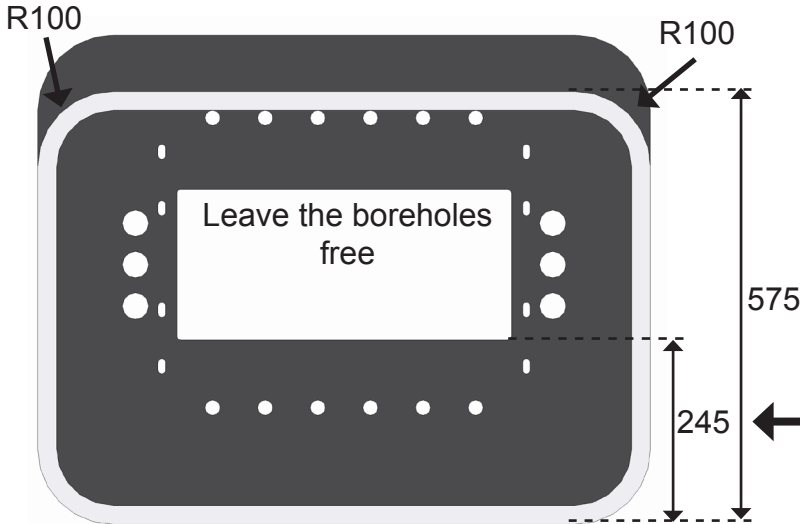

Positioning the rear part of the unit position on the edge

⚠ Take care with the measurement.

6 Position the unit on the hatch metal, introducing the studs in the slide boreholes as indicated in 6a and 6b.

CAUTION! When positioning the unit above the hatch gap, check that the wastewater run-offs are not blocked by the EPDM seal.



TGA / TGX cabin XLX model with spoiler

 **Caution:** The spoiler must be modified in order to install this model. All modifications must be authorised by the customer. In consequence, dirna Bergstrom shall be released from any liability deriving from modification of the spoiler.

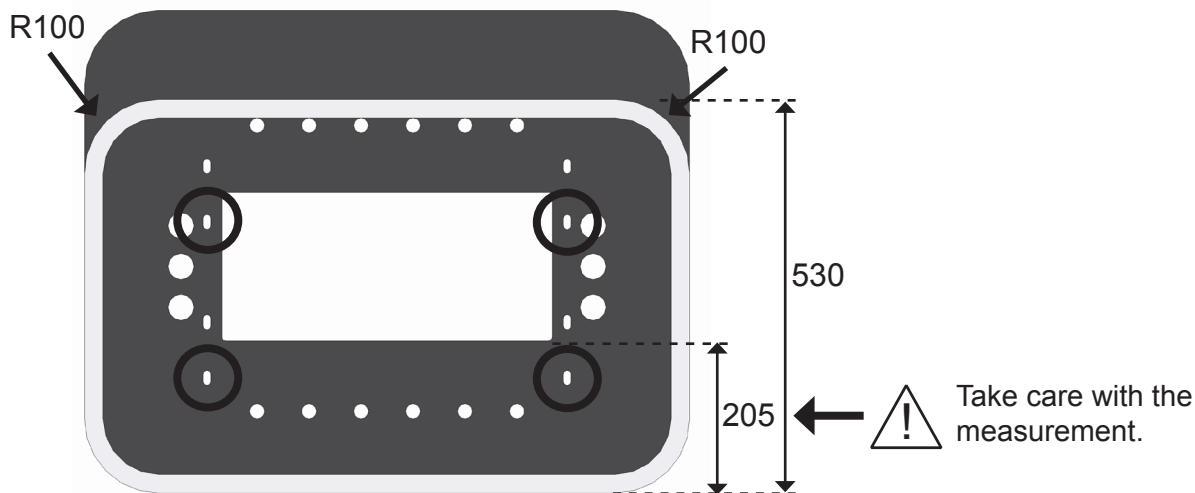

TGA / TGX cabin XLX model without spoiler

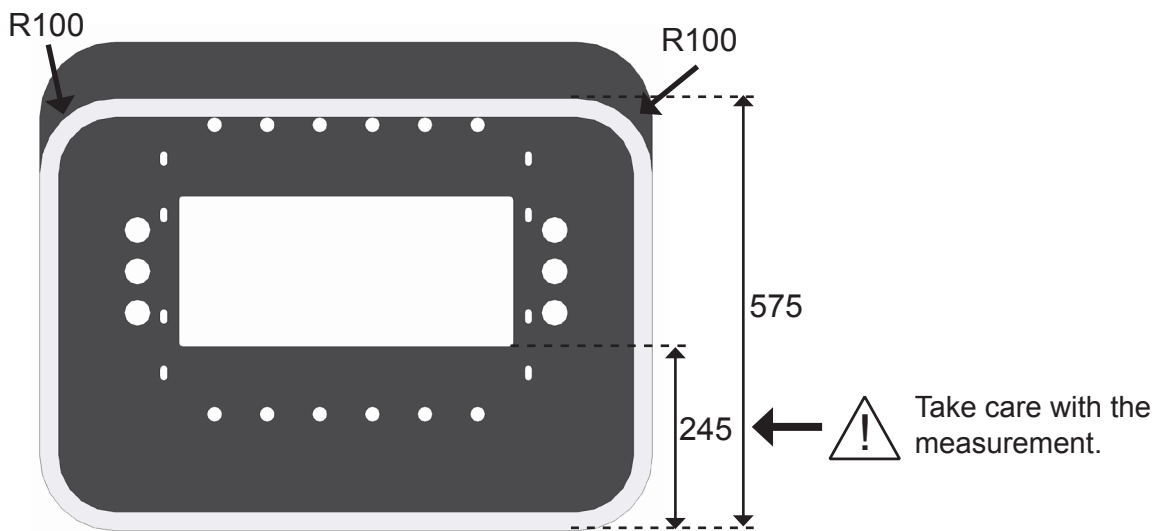

7 Position (1) flat washer and (1) nut on each stud and tighten until the nuts to fasten the studs to the base come up against the metal.

8 Via the front section, position the equipment with the plate on the hatch of the vehicle. **The hatch plate must remain level with the EPDM seal.**



9 Via the interior section, laterally align the equipment in the hatch.
 ⚠ **Important: If the seal (A) is not attached to the base, remove the protective paper and attach as indicated.**

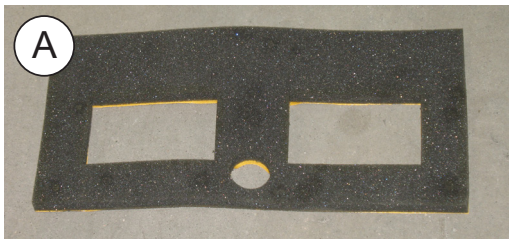
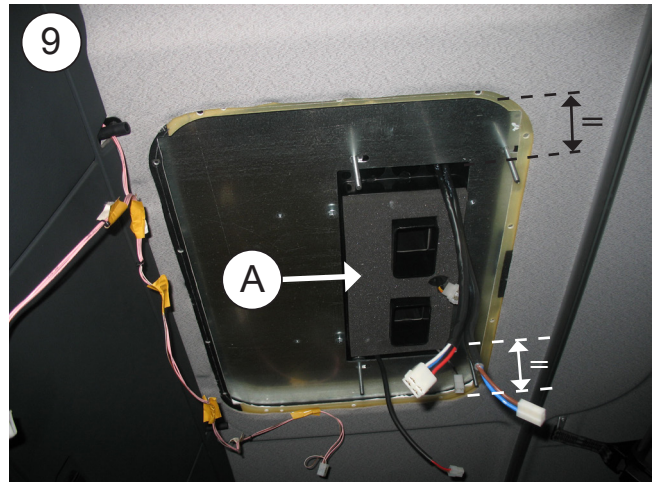

10 Attach the ducts in the interior air distribution panel.
 ⚠ **Important: Any channelling equipment (B) included should be discarded as it is not valid for this unit.**

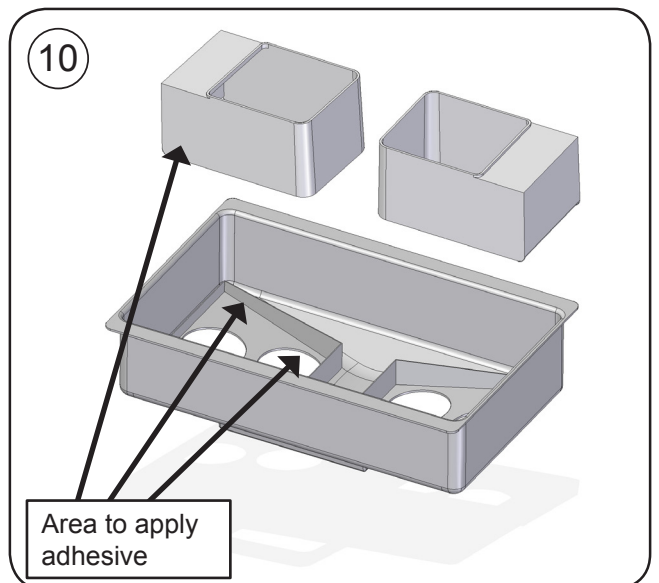

11 Connect the (2) 4-way boxes and the (2) 2-way boxes and connect the power cable in the 2-way box in a “T” between the unit and the interior air distribution panel.

NOTE: It is very important not to invert the colours of the condenser fan 2-way box (box with R and N wires).



12 Position the interior air distribution panel on the studs closest to the front glove compartments on the metal, and secure with M6x25 hexagon (Take care to ensure there is no cabling which interferes between the ducts and the unit).

CAUTION: Position the interior air distribution panel so the ducts fit against the unit’s base seal.

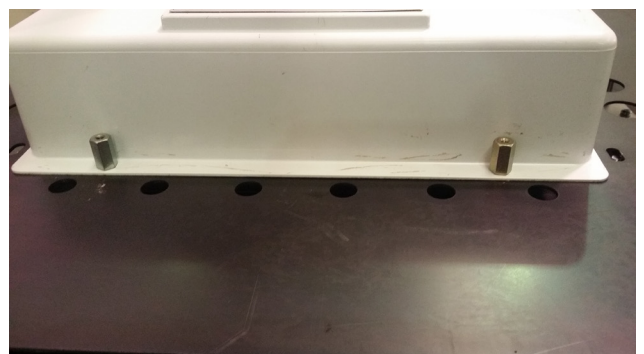

12a Position the console and align the unit in the original console location.



13 Place brackets on studs M8, secured with washers and nut Ø8 brimmed M8 self-locking tightening them until the carrier contacts in the middle of the plate.

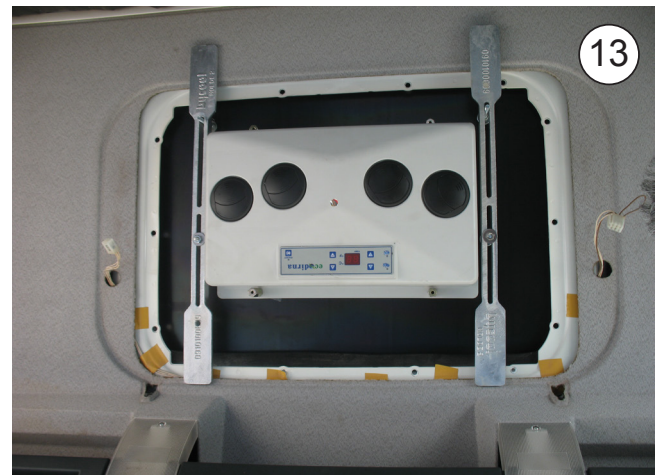

14 Position the console with (4) 6/100x15 Allen screws.

⚠ NOTE: Take out the original interior wiring through the gaps in the consoles.



15 Connecting and mounting original lights on the console.



16 Cover the (4) Allen screws M6/100x15 with the M6 round plastic decorative pieces.



17 Connect and attach the cabling with the plastic supports and flanges to the cabin ceiling (carefully clean the area first).



Exploded side view to supports fastening

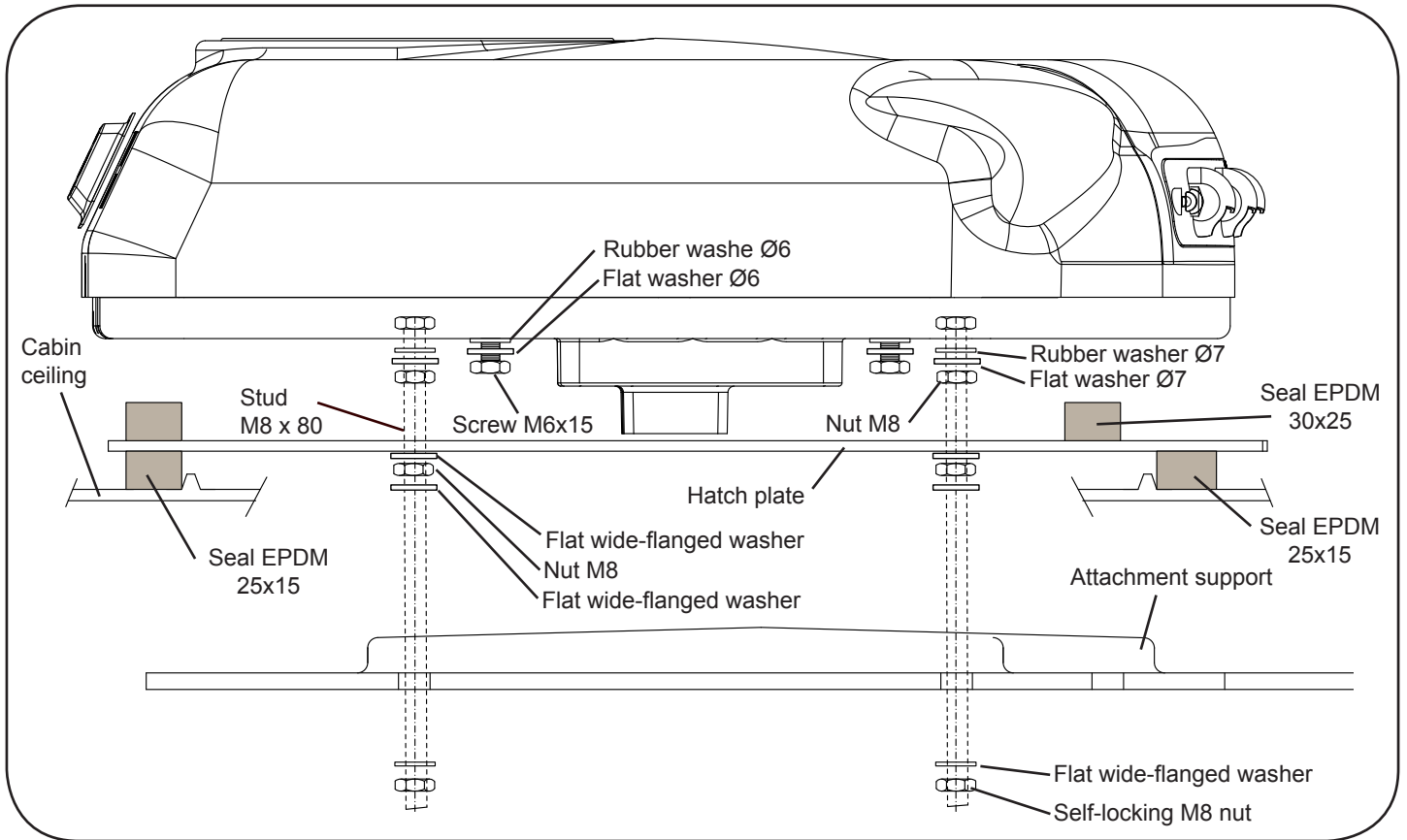

Exploded rear view to consoles fastening

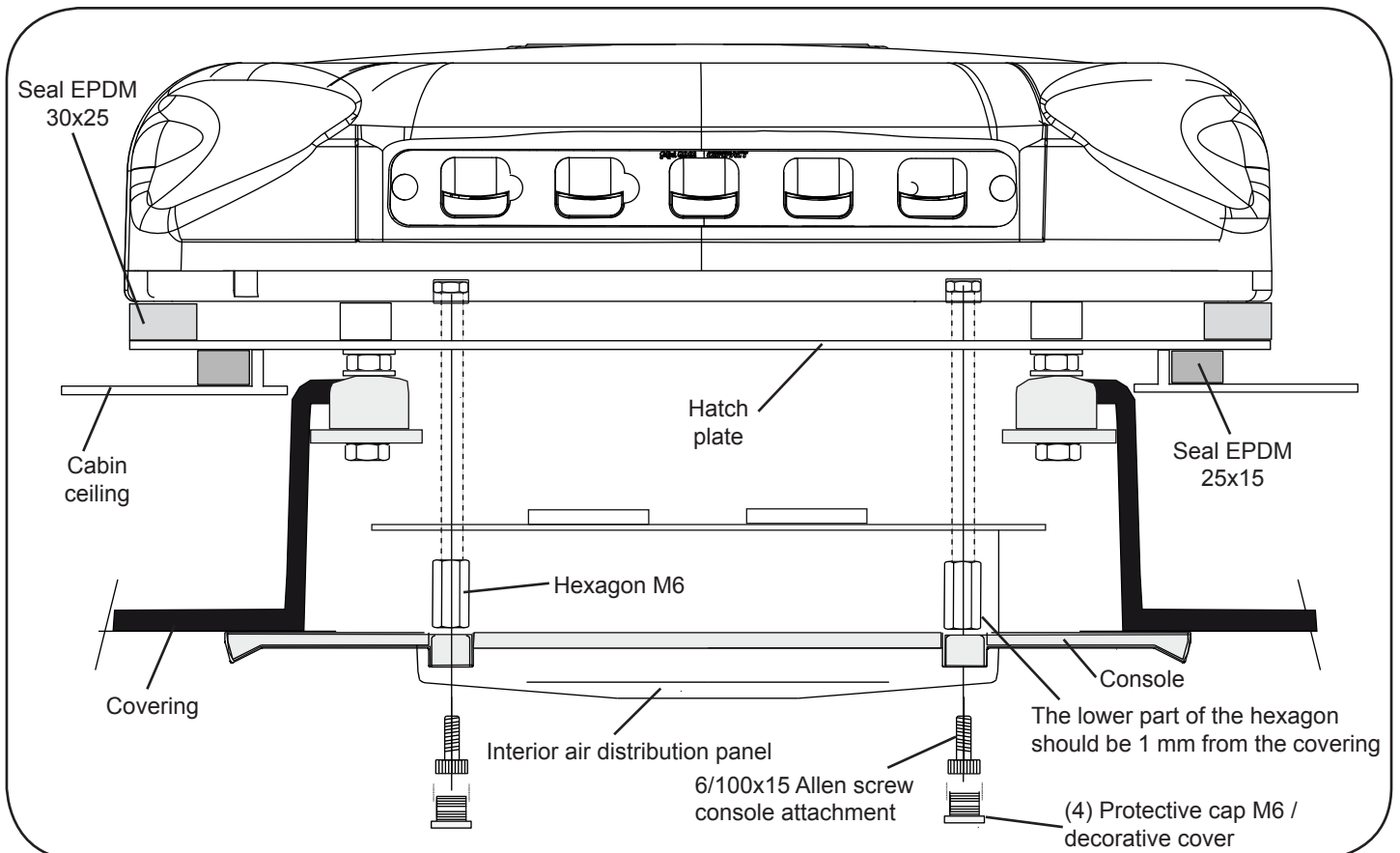

Detailed instructions on power wiring assembly



1- Lead equipment power cable up to the vehicle's battery, gluing plastic supports on rear cabin side and fastening it with flanges. Once cabin has been folded, lead cable along lower cabin side, fastening it with clamps and M4 screws and up to battery with flanges. It must follow the same passage as original cable (*thoroughly clean the area before gluing plastic supports*). When connecting equipment to battery, it will carry out a test of all its leds, **88--bd** will show on the display and it will then be turned off.

⚠ IMPORTANT: Due to the equipment's complex electronic regulation system, the current connection must be made directly to the vehicle battery point or authorised connection point, and not to any other point which services other accessories of the vehicle, taking the precaution to not invert polarity when making the connection.

⚠ IMPORTANT: Please consult User's Guide before starting.

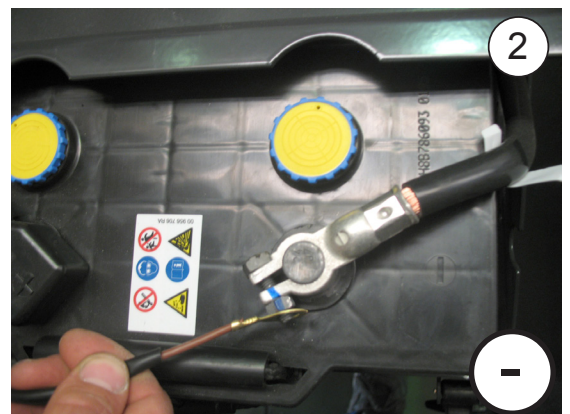

Electric wiring

IMPORTANT WARNING!

Take care not to invert the polarities when connecting the equipment to the battery. If this happens, the plate does not come on and the unit does not work.

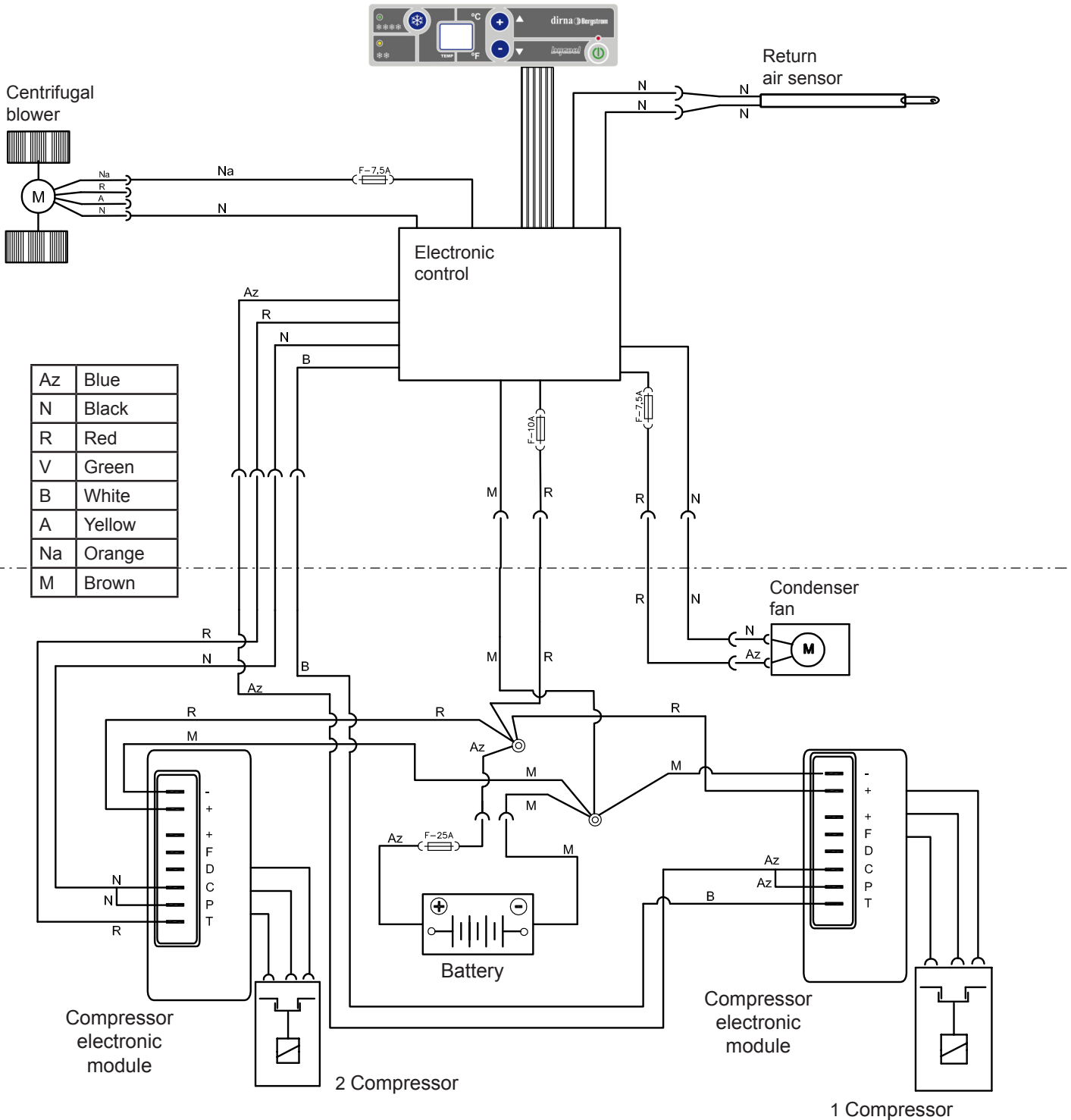

For XLX cabins with spoiler
Changes to make in the spoiler

1 Mark the indicated measures, protect with masking tape to prevent damage to the spoiler and make the cut.

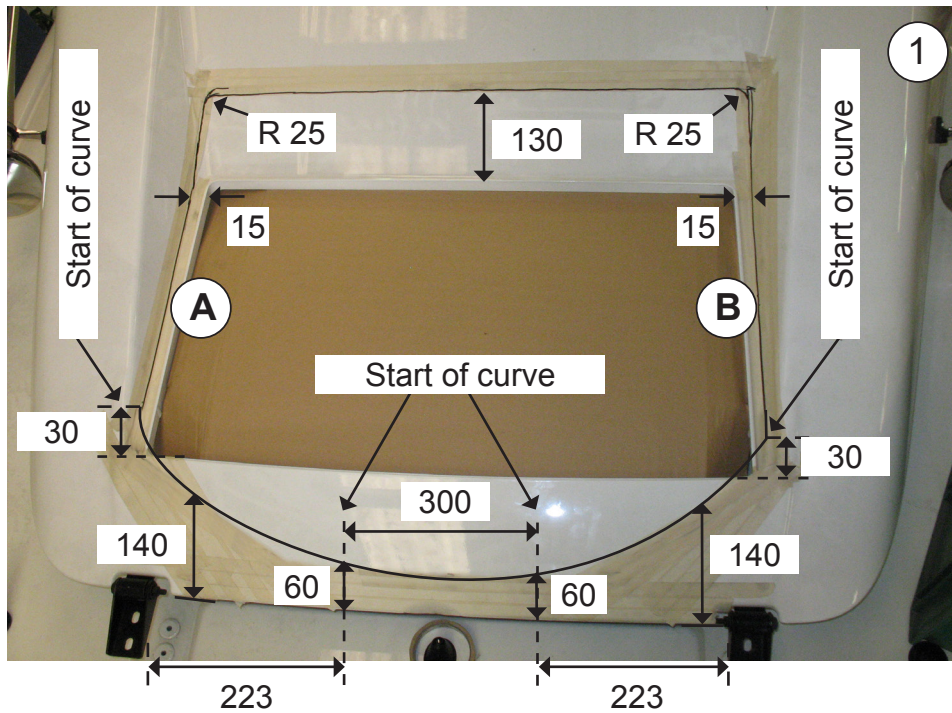

Lower spoiler view

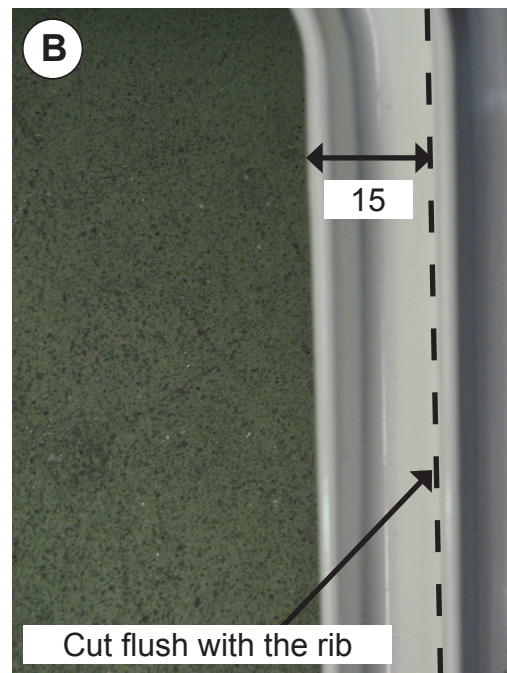
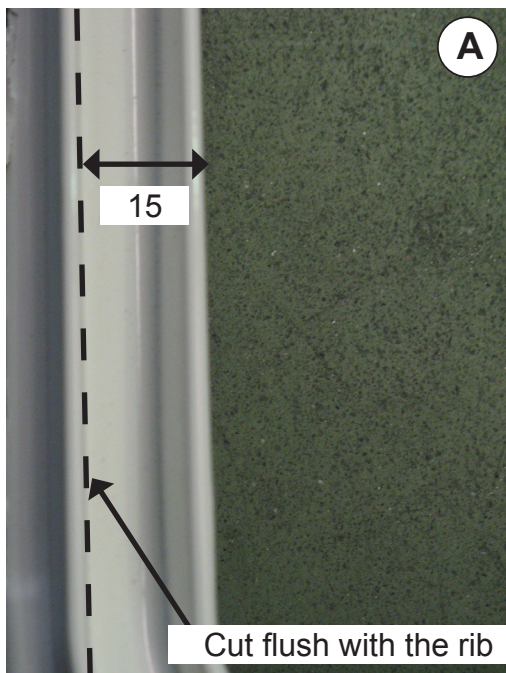

2 Place the spoiler back using the original screws.



Recommandations Pour Le Montage

- Avant de commencer le montage de l'appareil, prière de lire les instructions et de les suivre attentivement.
- Utiliser les outils convenant à chaque opération.

Electricity

- Déconnecter la clé de contact.
- Déconnecter la batterie avant de commencer le montage.
- Vérifier le câblage des composants électriques et leur correcte installation.

Attention

Si pendant le montage l'équipement est incliné, il faudra attendre au moins 60 minutes avant de le mettre en marche une fois qu'il aura été remis sur sa position horizontale.

Attention

Lors de l'installation de l'appareil d'air conditionné sur le toit, il faudra protéger la partie supérieure de la cabine avec un linge ou une couverture de protection afin d'éviter les éventuelles égratignures.

Durant l'installation du **Compact**, tenir compte du fait que normalement les cabines pourvues d'écouille possède une structure suffisamment solide pour supporter le poids de l'appareil. Cependant, si ce n'est pas le cas et qu'il est nécessaire de découper le toit ou même si disposant d'écouille, la structure n'est pas suffisamment rigide (si elle était en fibre, plastique, etc.) il appartiendra à l'installateur de décider s'il faut renforcer le toit pour éviter toute déformation, rupture ou voie d'eau, etc., et prendre les mesures nécessaires à cet effet.







Outils

Jeu de clés Torx
 Jeu de clés Allen
 Clé fixe 10, 13, 14
 Ciseaux
 Mètre

Documentation included

Instructions de montage	220.AA3.3080
Guide de l'utilisateur	220.AA6.0170
Solution des problèmes	220.AA6.0013
Pieces fournies	220.RE0.0121
Garantie	220.AA1.0017

Garantie

-  L'installateur devra posséder la formation pertinente en air conditionné sur véhicules.
-  **dirna Bergstrom, s.l.**, ne sera pas responsable des dommages ou des bris dérivés d'une installation ou d'une manipulation incorrecte ni des modifications réalisées sans autorisation expresse par écrit.
-  **Appareil pré-chargé de gaz réfrigérant. (Ne pas manipuler le circuit de gaz réfrigérant).**
-  Voir la **procédure de garantie** du produit au **Diagnostic de problèmes**.
-  Voir le **Guide de l'Usager** de l'appareil pour le fonctionnement correcte de la télécommande et du tableau de commande.
-  Après l'installation, vous devez fournir à l'utilisateur: Manuel d'utilisation, garantie et diagnostic de pannes.

 Avant de commencer le montage, monter la grille d'entrée d'air frontale.



 Pour véhicules **TGX cabine XLX avec spoiler** les modifications à réaliser devront être autorisées par le client. Par conséquent, **dirna Bergstrom décline toute responsabilité** de la modification du spoiler. Si les modifications à réaliser sur le spoiler sont autorisées, ce dernier sera déposé avant de commencer l'installation.

1 Démontez le spoiler. Démontez couvercle trappe, les éléments de fixation et les remettez au client.



2 Retirer les résidus excédants, adhérents au plafond avant de coller le joint EPDM.

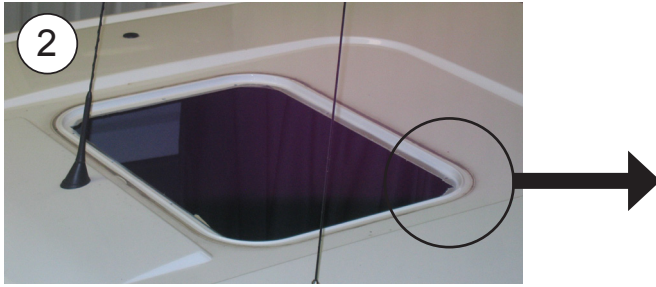

3 Coller le Joint EPDM 25x15 autour de la saillie de la cavité de la trappe (voir le détail pour découper les bords finals d'union du joint).

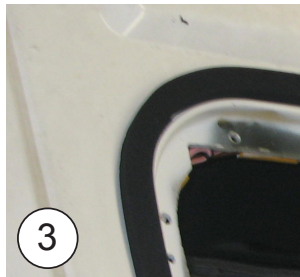

COMMENT COUPER LE JOINT EPDM POUR EVITER LA FILTRATION D'EAU DANS LA CABINE

- A-** Coller le joint, en maintenant 100 mm de papier protecteur de chaque côté.
- B-** Retirer les deux pièces de papier.
- C-** Coller en faisant pression sur les deux extrémités.

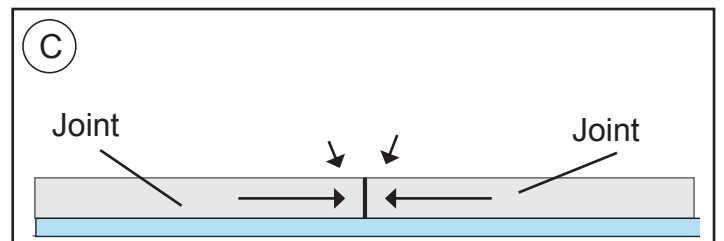
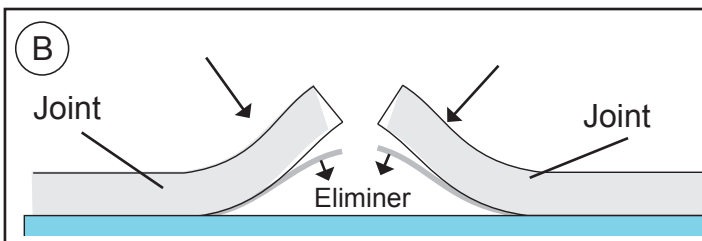
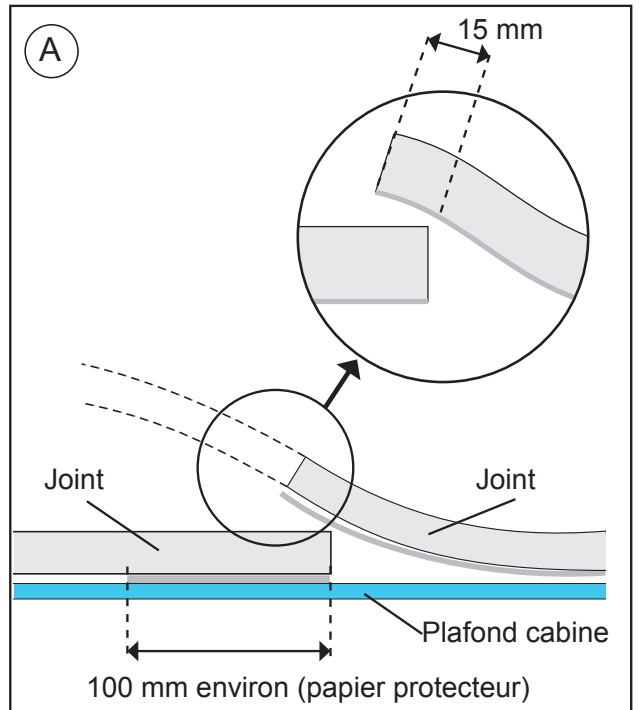

4 Visser 10 mm. (4) goujons M8x85 sur la base Compact, puis introduire par-dessus (1) rondelle en caoutchouc Ø 20 x Ø 7 x 3, (1) plane Ø 6 et (1) écrou M8. Serrer contre la base.

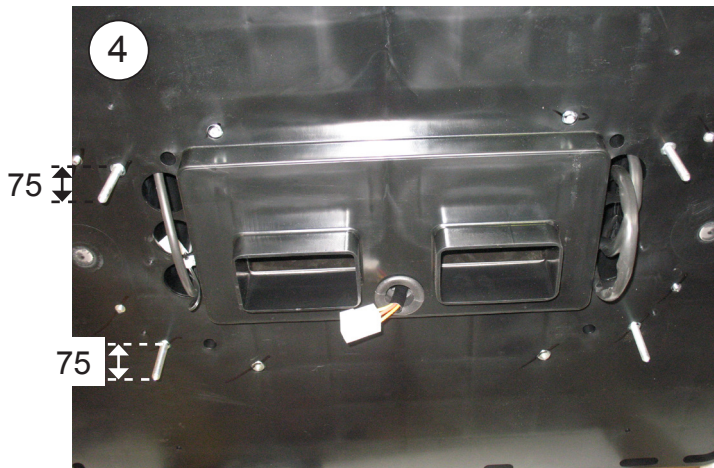

TGA / TGX cabine modèle XLX avec spoiler

 **Attention** : pour l'installation de ce modèle, il faut effectuer des modifications sur le spoiler. Ces dernières doivent être autorisées par le client. **dirna Bergstrom ne sera en aucun cas responsable des modifications réalisées sur le spoiler.**

5 Coller le joint EPDM 30x25 dans la plaque de l'écouille, tel que cela est indiqué.
ATTENTION: nettoyer préalablement la plaque pour garantir l'adhésion optimale du joint EPDM.

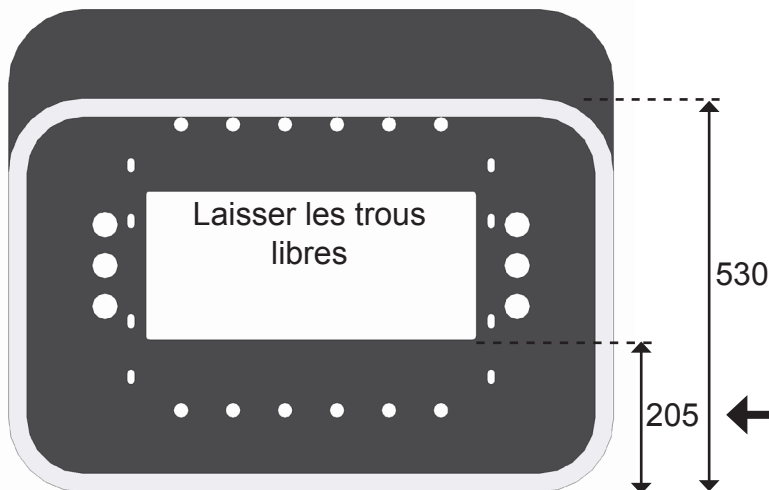
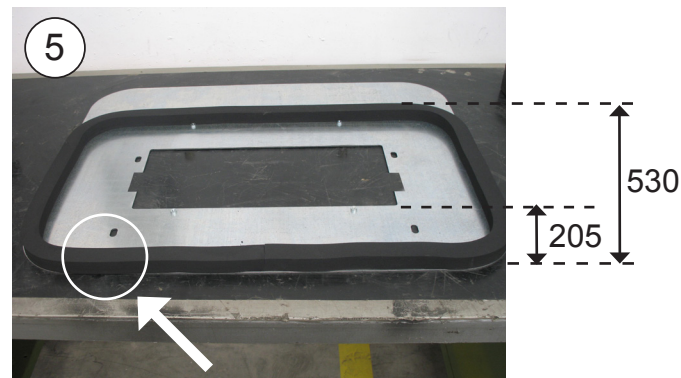

Mise en place partie arrière de l'équipement Placer le bord

 Attention à la mesure

TGA / TGX cabine modèle XLX/XXL sans spoiler

5a Coller joint EPDM 30x25, tel que cela est indiqué.

Attention : nettoyer préalablement la plaque pour assurer l'adhésion du joint EPDM.

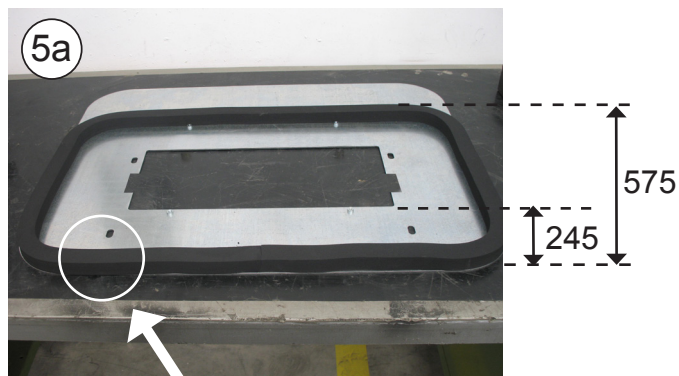
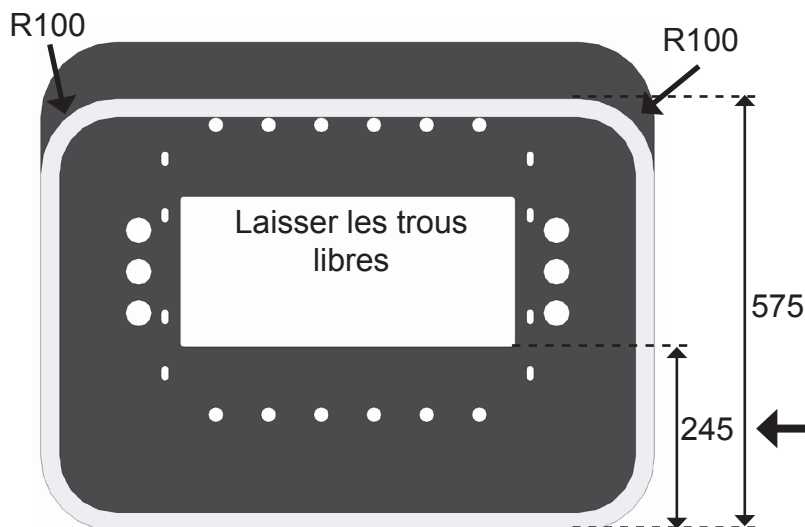

Mise en place partie arrière de l'équipement Placer le bord

⚠ Attention à la mesure

6 Placer l'équipement sur la plaque de l'écouille et introduire les goujons filetés dans les trous avec glissière de la plaque indiquée sur 6a et 6b.

ATTENTION ! Avant de placer l'équipement sur le creux de l'écouille, vérifier que les sorties d'écoulement ne soient pas bouchées par le joint EPDM.

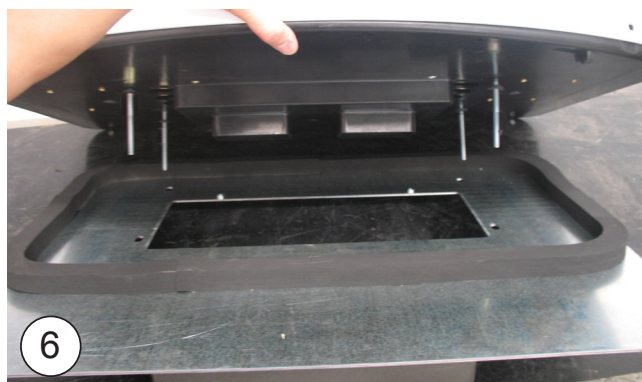

TGA / TGX cabine modèle XLX avec spoiler



Attention : pour l'installation de ce modèle, il faut effectuer des modifications sur le spoiler. Ces dernières doivent être autorisées par le client. **dirna Bergstrom ne sera en aucun cas responsable des modifications réalisées sur le spoiler.**

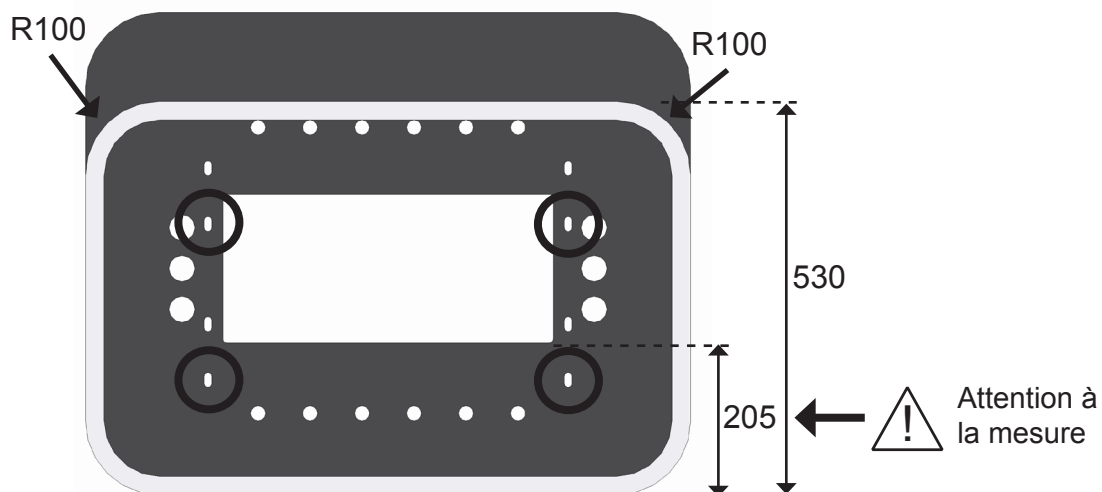

TGA / TGX cabine modèle XLX/XXL sans spoiler

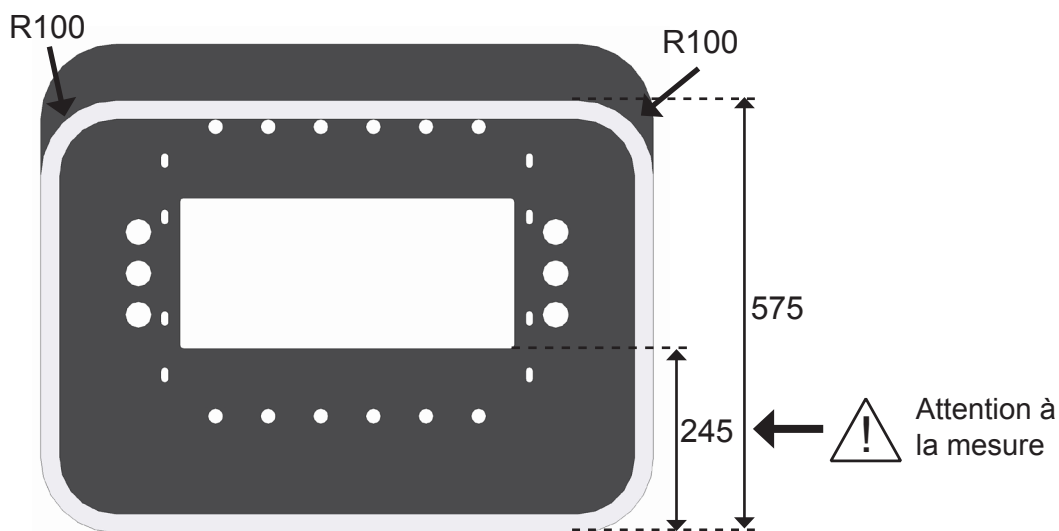

- 7** Introduire (1) rondelle plate et (1) écrou dans chaque goujon fileté et serrer jusqu'à atteindre la plaque avec les écrous de fixation des goujons filetés à la base.

- 8** Positionner équipement avec tôle sur la cavité de la trappe du véhicule par la partie avant, la tôle trappe doit rester à ras du joint EPDM.



- 9** Par la partie intérieure, centrer latéralement l'équipement dans la cavité de la trappe.

⚠ **Important :** si le joint (A) n'est pas collé à la base, retirez le papier protecteur de ce dernier et collez-le en suivant les indications.

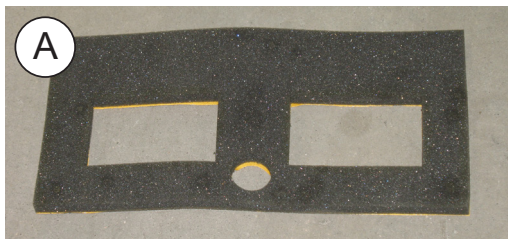
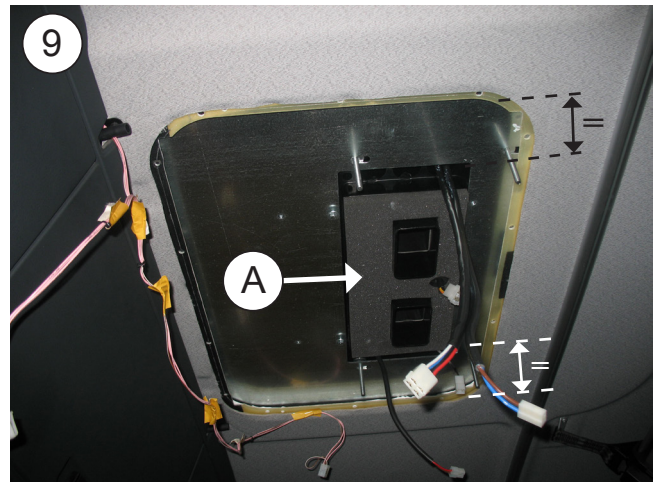

- 10** Coller les canalisateurs au panneau intérieur de distribution d'air.

⚠ **Important :** si l'équipement incorpore des canalisateurs (B), ils seront éliminés, car ils ne sont pas valables pour cet équipement.

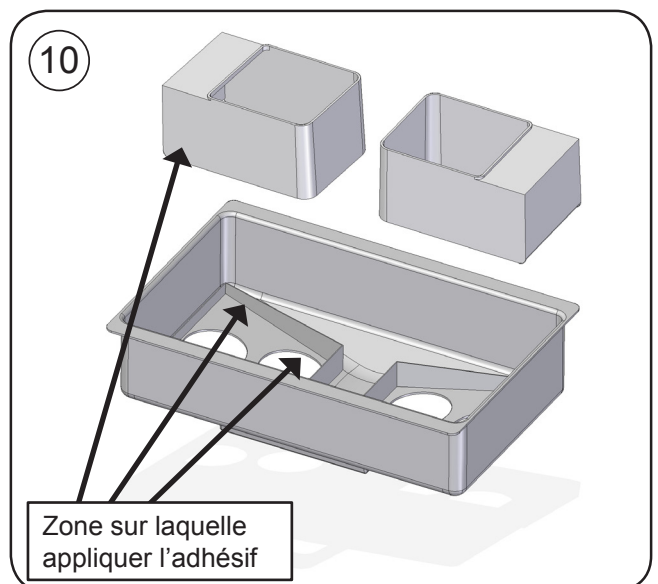

11 Connecter les (2) boîtiers à 4 voies, les (2) boîtiers à 2 voies et connecter le câblage d'alimentation au boîtier à 2 voies en "T" entre l'équipement et le panneau intérieur de distribution d'air.

ATTENTION : il est très important de ne pas inverser les couleurs de la boîte à 2 voies du ventilateur du condenseur (boîte avec câbles R et N).



12 Introduire le panneau intérieur de distribution d'air dans les goujons existants les plus proches des boîtes à gants à l'avant, sur la plaque, en fixant avec un hexagone M6x25 (**attention de ne pas interférer de câblages entre les canalisateurs et l'équipement**).

ATTENTION : placer le panneau intérieur de distribution d'air de façon que les canalisateurs soient ajustés par rapport au joint de la base de l'équipement.

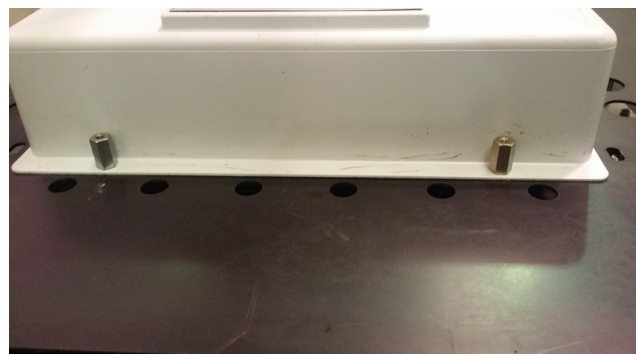

- 12a** Présenter la console et centrer l'équipement de façon à ce qu'il reste à l'emplacement de la console d'origine.



- 13** Placer des supports sur les goujons M8, fixer avec des rondelles Ø8 à ailette large et écrou M8 auto-bloquant jusqu'à ce que le support fasse contact avec la partie centrale de la tôle.

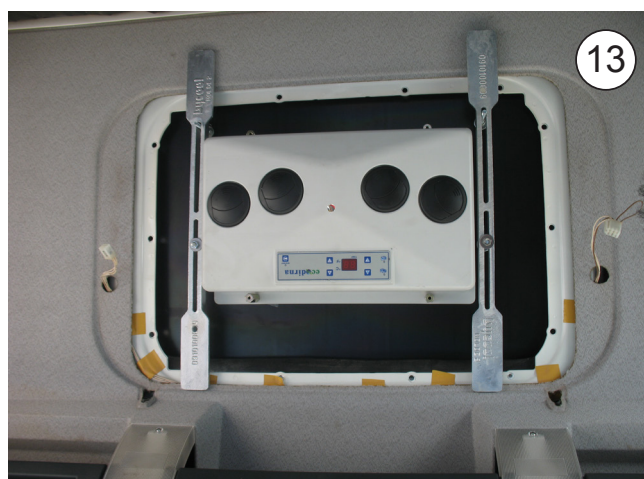

- 14** Placer la console avec (4) vis 6/100x15 allen.
 ⚠ **ATTENTION : sortir les câblages originaux de l'éclairage intérieur à travers les creux des consoles.**



15 Brancher et monter les lumières originales sur les consoles.



16 Couvrir les (4) vis M6/100x15 allen avec les enjoliveurs ronds de M6 en plastique.



17 Brancher et fixer le câblage avec supports en plastiques et brides au plafond cabine (bien nettoyer la zone avant).



Vue explosée jusqu'à la fixation des supports de fixation

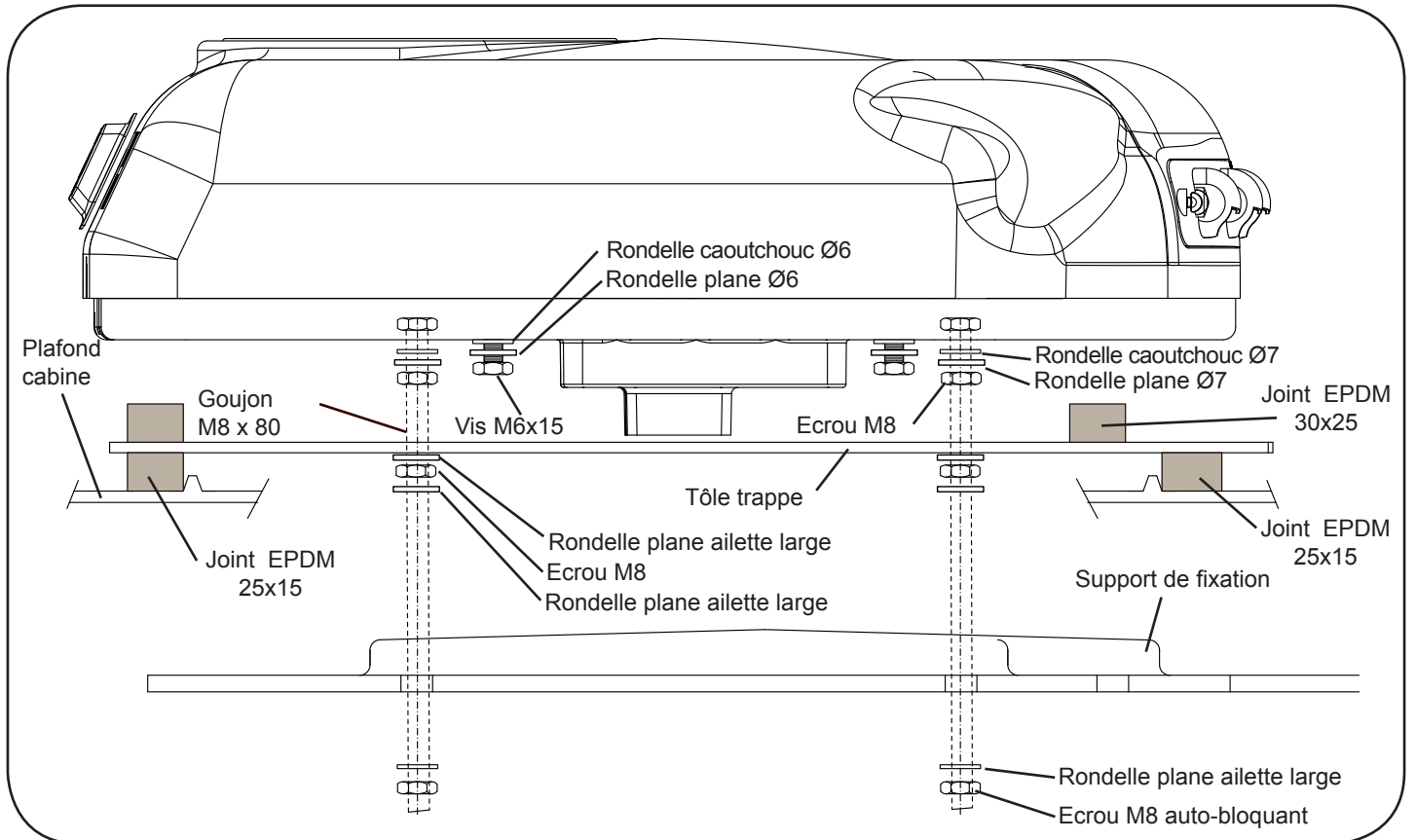

Vue explosée jusqu'à fixation des consoles

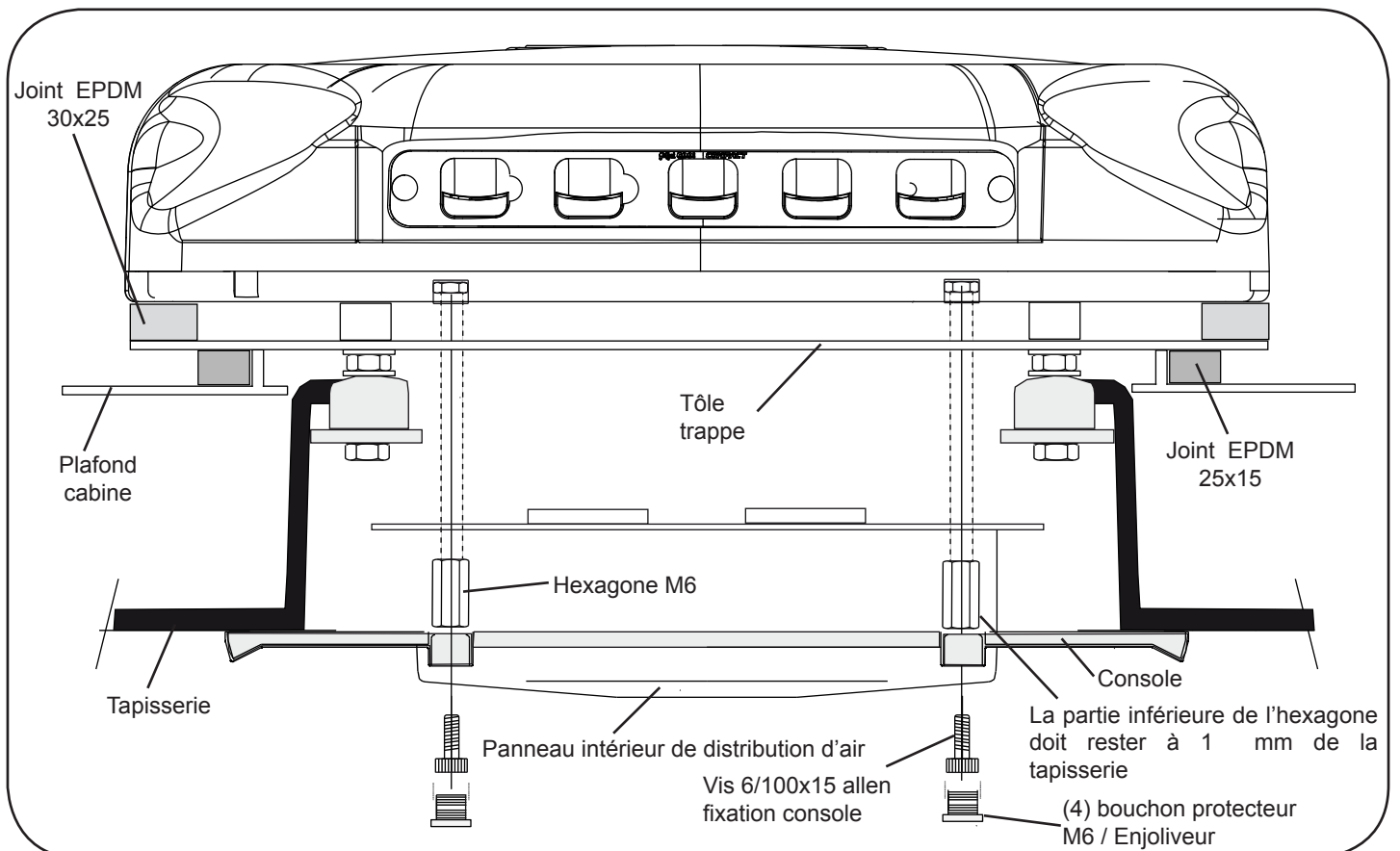

Instructions détaillées sur l'installation du câblage d'alimentation

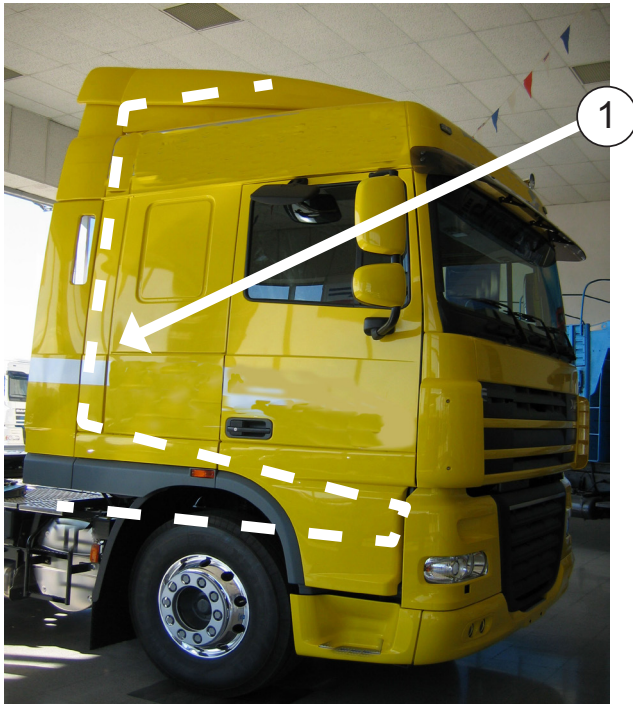

Câble
d'alimentation



1- Conduire le câble d'alimentation de l'équipement jusqu'à la batterie du véhicule, en collant les supports de plastique sur la partie postérieure de la cabine et en le fixant avec des brides. Ensuite, la cabine étant rabattue, passer le câble le long de la partie inférieure de celle-ci en l'attachant avec des colliers et des vis M4 et jusqu'à la batterie avec des brides. Il faut utiliser le même passage que celui du câblage d'origine (*pour coller les supports en plastique, bien nettoyer la zone préalablement*). Lorsque l'équipement sera connecté à la batterie, celui-ci testera tous ses leds, puis sera affiché sur le **88--bd** et s'éteindra.

⚠ IMPORTANT : en raison de la complexité du système de réglage électronique de l'équipement, la prise de courant doit se faire directement sur la batterie du véhicule ou prise autorisée, et non sur un tout autre point fournissant des services à d'autres accessoires du véhicule, en faisant attention de ne pas inverser la polarité au moment de la connexion.

⚠ IMPORTANT: pour la mise en marche, consulter le Manuel de l'Utilisateur.

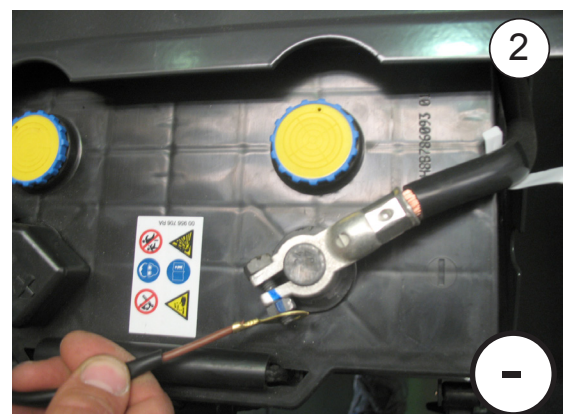

Câblage électrique

AVERTISSEMENT IMPORTANT!

Attention de ne pas inverser les polarités au moment de connecter l'équipement à la batterie. Si cela se produisait, la plaque de commande ne s'allumerait pas et l'équipement ne fonctionnerait pas.

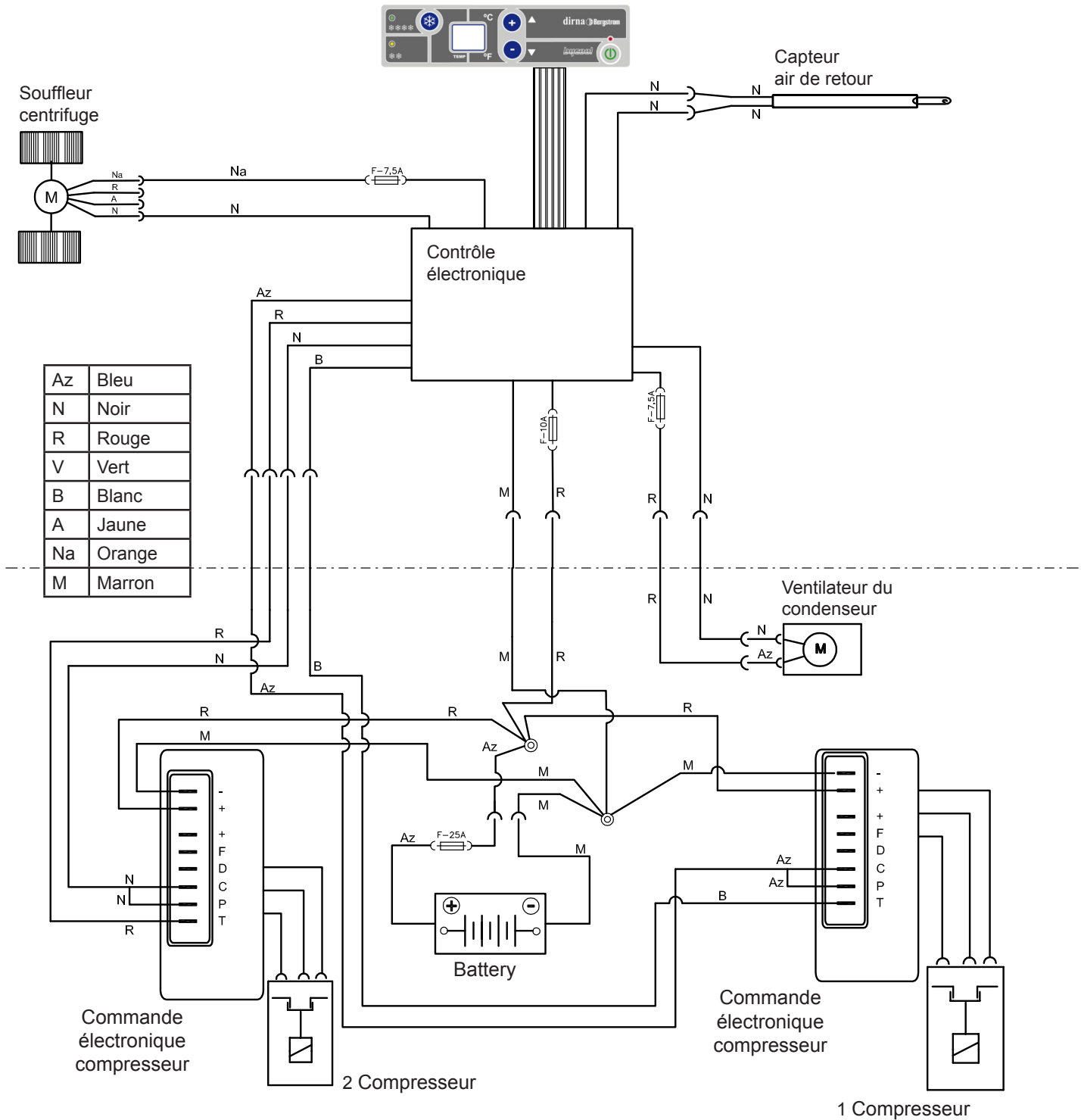

Pour cabines XLX à défecteur
Modifications à réaliser sur le défecteur

1 Marquer les mesures indiquées, protéger avec du ruban de masquage pour ne pas abîmer le spoiler et effectuer la coupe.

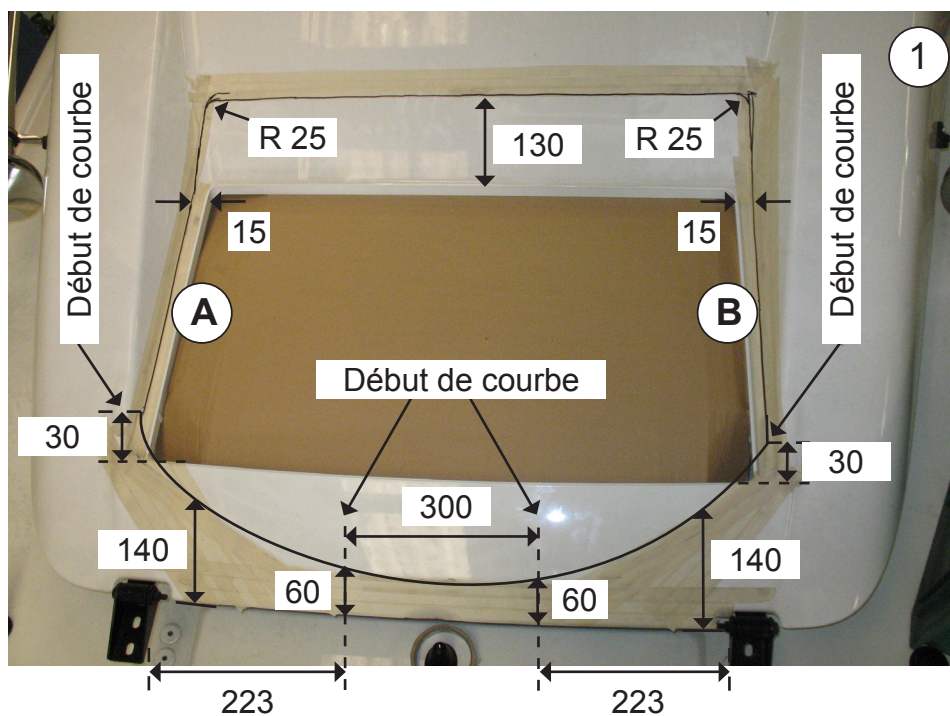

Vue partie inférieure spoiler

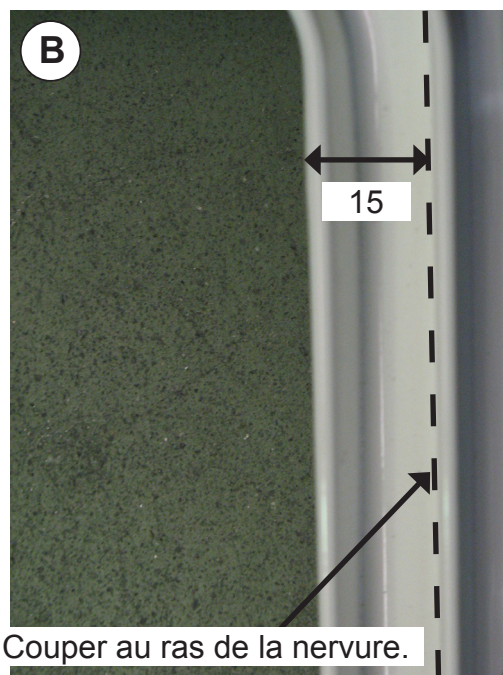
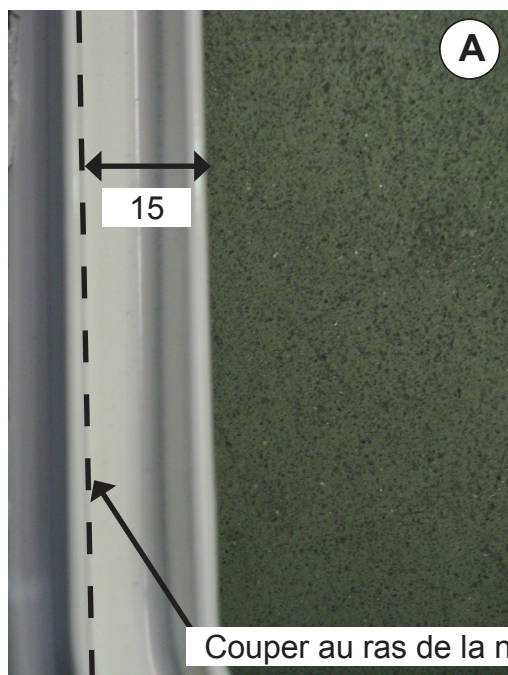

2 Monter le spoiler avec des vis d'origine sur sa position d'origine.



**Empfehlungen
Zur montage**

- Vor und während der Montage bitte diese Anweisungen lesen und beachten.
- Benutzen Sie für jeden Arbeitsschritt die geeigneten Werkzeuge.

Elektrizität

- Zündschlüssel abziehen.
- Vor Montagebeginn die Batterie abklemmen.
- Den ordnungsgemäßen Anschluss und die korrekte Installation der Elektrokomponenten überprüfen.

 **Achtung**

Sollte sich das Gerät während der Montage neigen, muss man mindestens 60 Minuten warten, nachdem es wieder in die horizontale Lage gebracht wurde, um es wieder einzuschalten.

 **Achtung**

Wird die Klimaanlage im Kabinendach installiert, muss der obere Teil der Kabine mit einem Tuch oder einer Decke gegen eventuelle Kratzer geschützt werden. Bei der Installation der **Compact** auf dem Kabinendach muss darauf geachtet werden, dass mit Luken ausgestattete Kabinen über eine ausreichend stabile Struktur verfügen, um das Gewicht des Geräts stand zu halten. Sollte das Fahrzeug über keine Luke verfügen und sollte es notwendig sein, das Kabinendach aufzuschneiden, bzw. sollte die vorhandene Struktur nicht ausreichend stabil sein (z.B. wenn sie aus Faser, Kunststoff usw. hergestellt ist), obliegt es dem Installateur zu entscheiden, ob das Kabinendach zur Vermeidung von Verformungen, Brüchen, undichten Stellen usw. verstärkt werden muss, und die hierfür notwendigen Mittel bereit zu stellen.







Werkzeuge

- Torx-Schraubenschlüssel
- Inbusschraubenschlüssel
- 10er, 13er, 14er Schraubenschlüssel
- Schere
- Metermaß

Mitgelieferte unterlagen

Montageanweisungen	220.AA3.3080
Benutzerleitfaden	220.AA6.0170
Fehlerdiagnose	220.AA6.0013
Lieferteile	220.RE0.0121
Garantie	220.AA1.0017

 **Warnhinweise**

-  Der Installateur muss im Bereich Fahrzeug-Klimaanlagen ausreichend geschult sein.
-  **dirna Bergstrom, s.l.** übernimmt keine Verantwortung für Schäden oder Brüche aufgrund einer nicht ordnungsgemäßen Installation oder Bedienung des Geräts oder den Austausch von Teilen bzw. Umbauten, die ohne die erforderliche schriftliche Genehmigung durchgeführt wurden.
-  **Mit Kältemittel vorgefülltes Gerät. (Kältemittelkreislauf nicht manipulieren).**
-  Siehe **Garantieverfahren** des Produkts in der **Fehlerdiagnose**.
-  Siehe **Benutzerleitfaden** des Geräts für den ordnungsgemäßen Betrieb der Fernbedienung und des Bedienfelds.
-  Die folgenden Unterlagen müssen dem Benutzer nach der Installation ausgehändigt werden: **Benutzerleitfaden, Garantie und Fehlerdiagnose.**

 Vor Montabeginn vorderes Lufteintrittsgitter montieren.



 Bei Fahrzeugen TGX Kabine XLX mit Spoiler müssen die an diesem durchzuführenden Umbauten vom Kunden genehmigt werden. Darum **übernimmt Dirna Bergstrom keinerlei Haftung** für Umbauten am Spoiler. Sind die erforderlichen Umbauten am Spoiler genehmigt, muss dieser vor der Installation ausgebaut werden.

1 Spoiler ausbauen. Lukendeckel und Befestigungsteile abnehmen und dem Kunden übergeben.



2 An der Decke haftende Reste entfernen, bevor die EPDM-Dichtung eingeklebt wird.

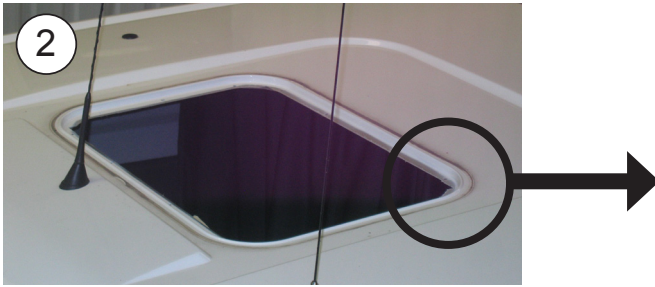

3 Kleben Sie die EPDM-Dichtung 25x15 um den Steg der Lukenöffnung. (Beachten Sie die Detailbeschreibung zum Beschneiden der Endverbindungskanten der Dichtung).

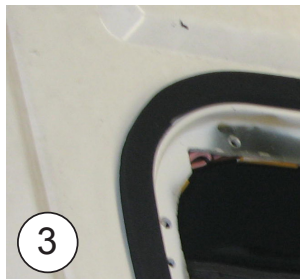

WIE BESCHNEIDET MAN DIE EPDM-DICHTUNG, UM DAS EINSICKERN VON WASSER ZU UNTERBINDEN

- A-** Dichtung einkleben und 100 mm des Schutzpapiers an jeder Seite überstehen lassen.
- B-** Die beiden Papierstücke entfernen
- C-** Kleben Sie die Dichtung ein, indem Sie beide Enden andrücken.

(A)

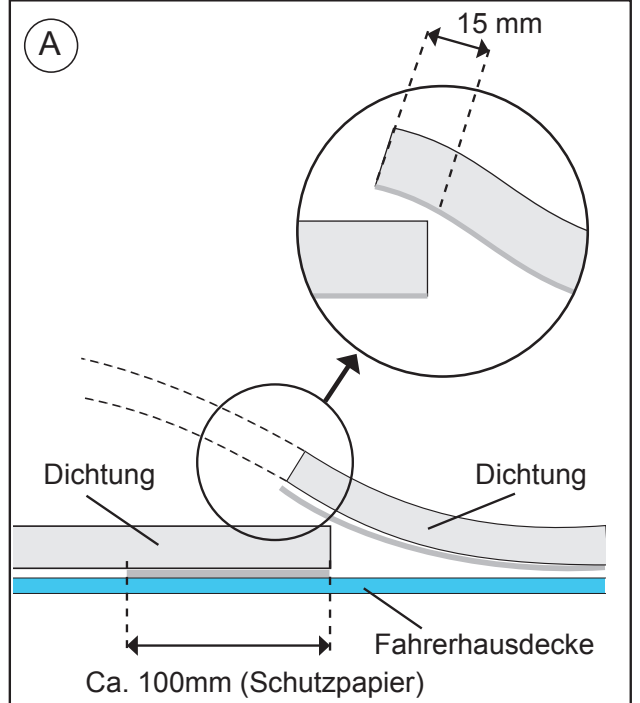

(B)

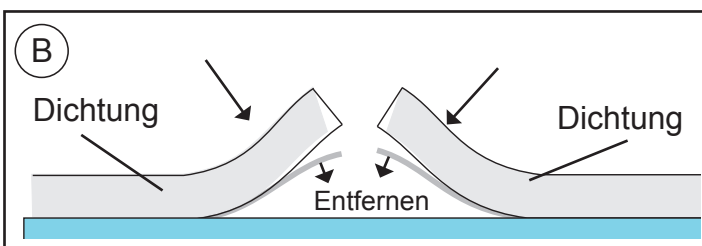

(C)

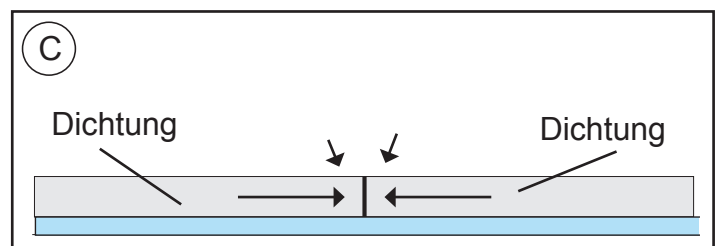

4 Vier (4) Gewindebolzen 5 mm M8x85 in die Unterlage Compact einschrauben, über diesen eine (1) Unterlegscheibe aus Gummi Durchm. 20 x 7 x 3, eine (1) flache Unterlegscheibe Durchm. 6 und eine (1) Mutter M 8 anbringen. Gegen die Unterlage anziehen.

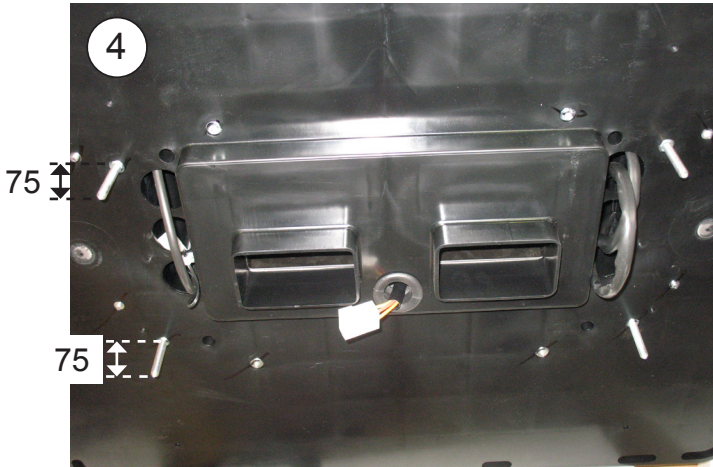

TGA/TGX Kabine Modell XLX mit Spoiler

 **Achtung:** Für die Installation dieses Modells müssen Änderungen am Spoiler durchgeführt werden, die vom Kunden genehmigt werden müssen. **dirna Bergstrom übernimmt keinerlei Haftung für die Änderung des Spoilers.**

5 EPDM-Dichtung 30x25 wie angegeben auf Lukenblech kleben.
ACHTUNG: Blech zuvor reinigen, damit die EPDM-Dichtung gut klebt.

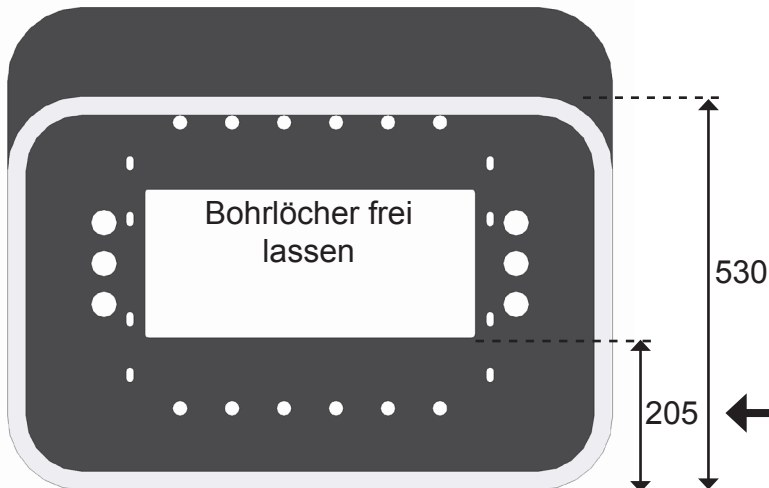
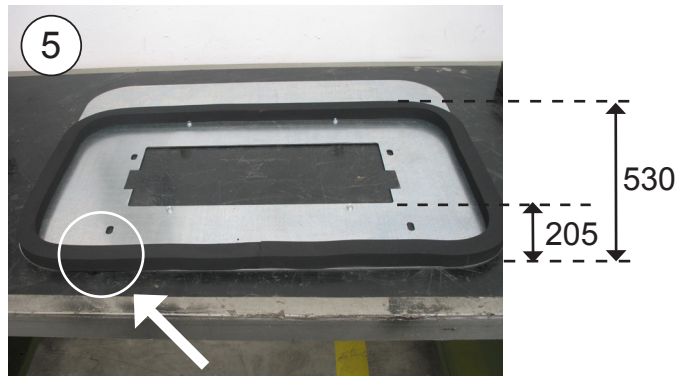

Anbringung Geräterückseite
Am Rand anbringen

 Beachten Sie das Maß

TGA/TGX Kabine Modell XLX/XXL ohne Spoiler

5a Die EPDM-Dichtung 30x25 wie angezeigt kleben.

Achtung: Vorher das Blech reinigen, um das Festkleben der EPDM-Dichtung zu garantieren.

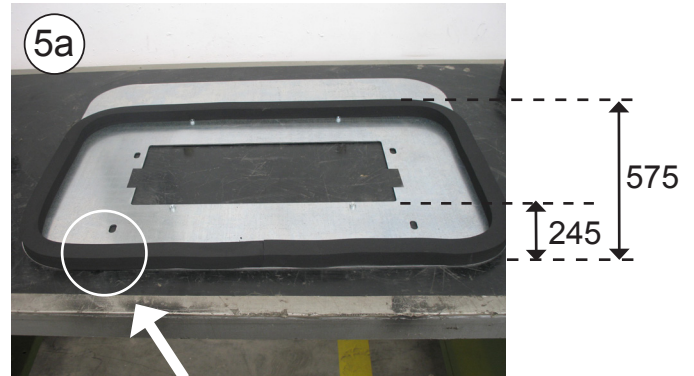
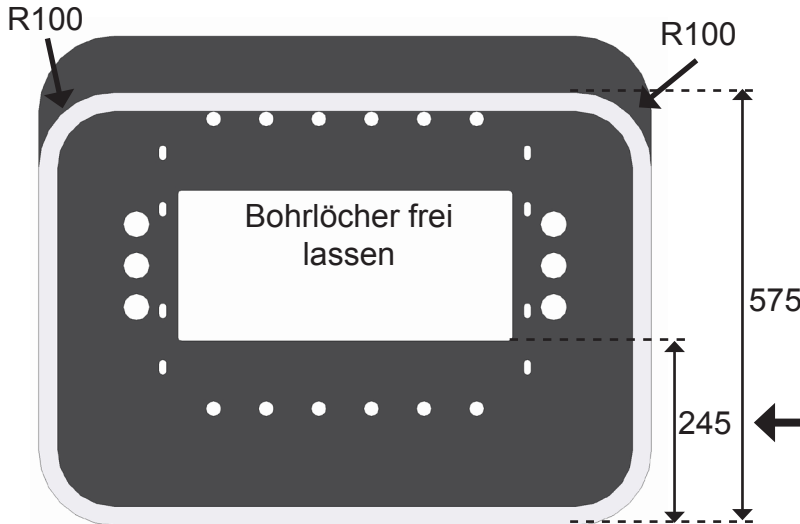

Anbringung Geräterückseite
Am Rand anbringen

⚠ Beachten Sie das Maß

6 Gerät auf Lukenblech setzen und dabei die Stiftschrauben in die Bohrlöcher mit Schieber des in 6a und 6b angegebenen Blechs stecken.

ACHTUNG! Beim Auflegen des Geräts auf die Lukenausparung darauf achten, dass die Ablassausgänge nicht von der EPDM-Dichtung zusammengedrückt werden.

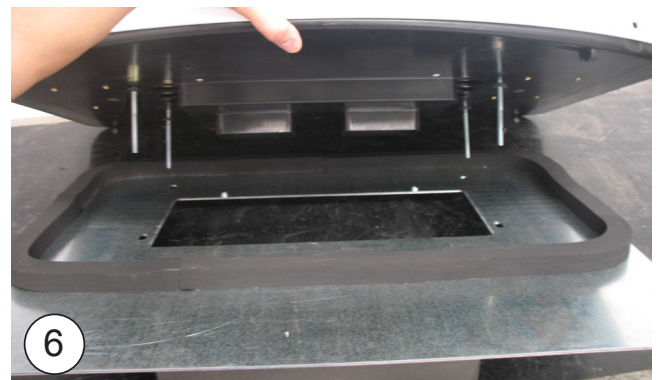

TGA/TGX Kabine Modell XLX mit Spoiler



Achtung: Für die Installation dieses Modells müssen Änderungen am Spoiler durchgeführt werden, die vom Kunden genehmigt werden müssen. **dirna Bergstrom übernimmt keinerlei Haftung für die Änderung des Spoilers.**

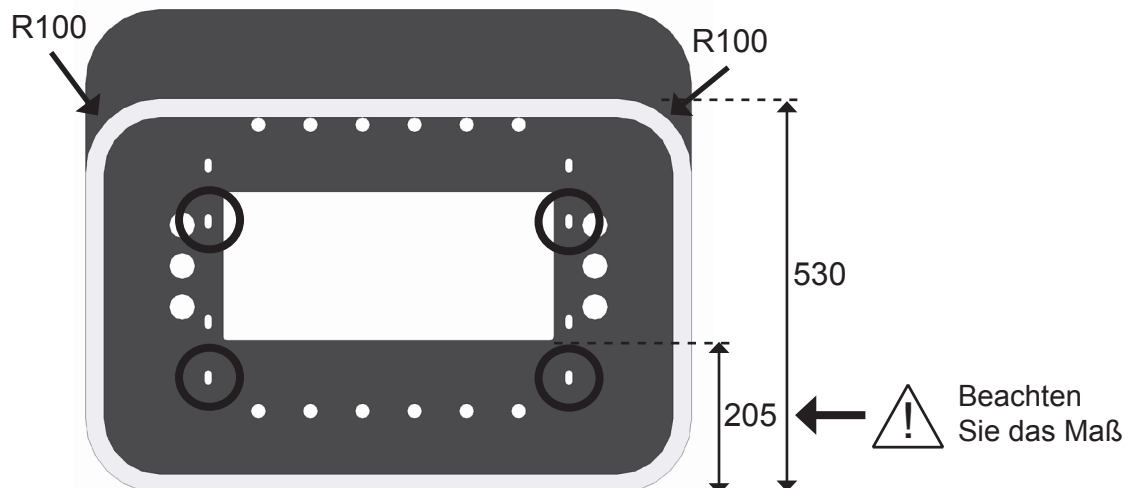

TGA/TGX Kabine Modell XLX/XXL ohne Spoiler

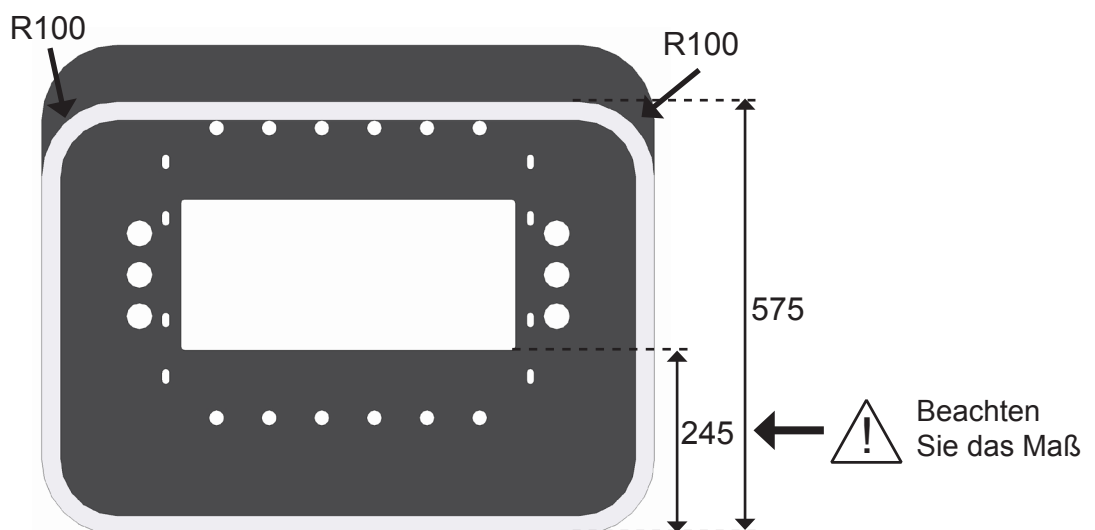

- 7** (1) Flachscheibe und (1) Mutter auf jede Stiftschraube stecken und anziehen, bis das Blech mit den Befestigungsmuttern der Stiftschrauben an die Grundplatte stößt.

8 Anlage mit dem Blech auf der Lukenöffnung des Fahrzeugs platzieren. Auf der Vorderseite muss das **Lukenblech bündig mit der EPDM-Dichtung abschließen**.



9 Anlage von innen seitlich in der Lukenöffnung zentrieren.
 ⚠ **Wichtiger Hinweis:** Sollte die Dichtung (A) nicht bereits an der Grundplatte kleben, den Schutzstreifen abziehen und wie gezeigt aufkleben.

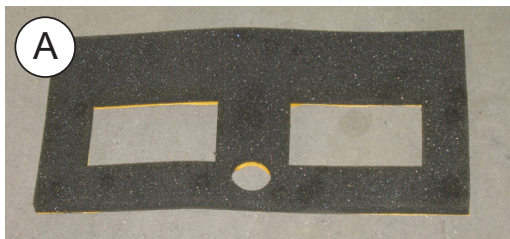
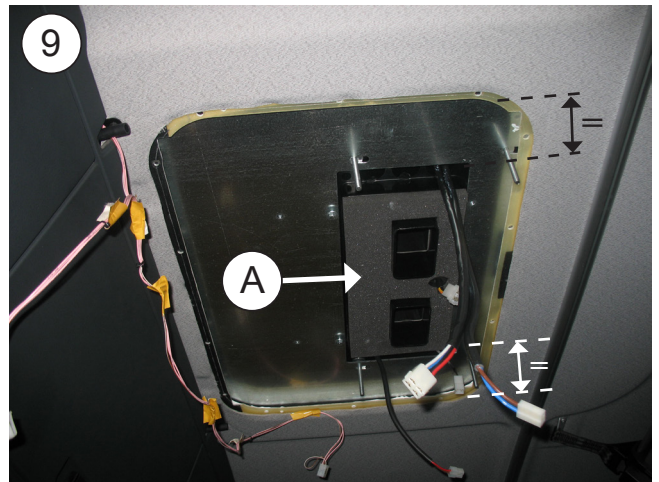

10 Führungen auf die innere Luftverteiltertafel kleben.
 ⚠ **Wichtiger Hinweis:** Wenn die Anlage Luftführungen (B) beinhaltet, sind diese herauszunehmen, da sie für diese Anlage nicht benötigt werden.

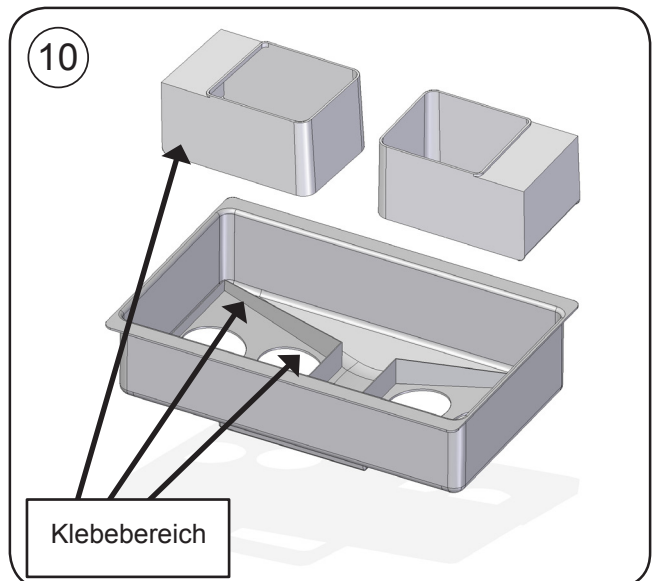

11 Die (2) 4-Wege-Kästen und die (2) 2-Wege-Kästen zwischen der Anlage und der inneren Luftverteiltertafel anschließen und danach das Netzkabel am 2-Wege-Kasten als "T" .

ACHTUNG: Die Farben des 2-Wege-Kastens des Elektrolüfters dürfen (Kasten mit Kabeln R und N) keinesfalls vertauscht werden!



12 Innere Luftverteiltertafel auf die vorhandenen Stiftschrauben stecken, die den vorderen Handschuhfächern auf dem Blech am nächsten sind und mit Sechskant-Verbindungs-mutter M6x25 befestigen. (Dabei darauf achten, dass die Kabel nicht zwischen Führungen und Gerät eingeklemmt werden).

ACHTUNG: Die Luftverteiltertafel so positionieren, dass die Führungen mit der Dichtung der Gerätegrundplatte übereinstimmen.

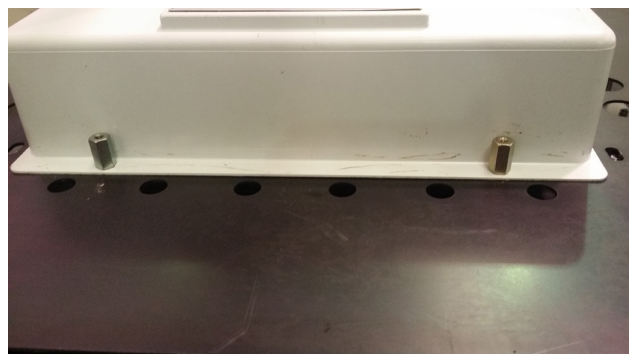

12a Konsole auflegen und Gerät so zentrieren, dass es sich an der Stelle der Originalkonsole befindet.



13 Unterstützungen auf die Stiftschrauben M8 legen und mit Breitflanschscheiben Ø8 und selbstblockierender M8-Mutter anziehen, bis die Unterstüzung im mittleren Teil auf dem Blech aufliegt.

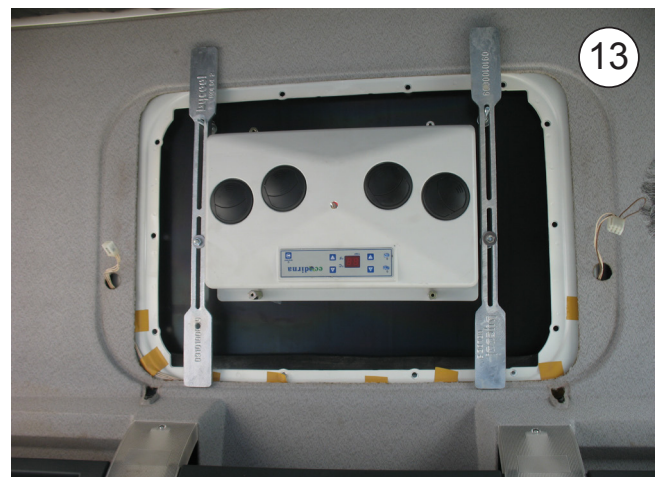

14 Konsole mit (4) Innensechskantschrauben M6/100x15 anbringen.

⚠ ACHTUNG! Originalkabel der Innenbeleuchtung über die Aussparungen der Konsolen herausziehen.



15 Originalleuchten in die Konsolen montieren und anschließen.



16 Die (4) M6/100x15 Inbusschrauben mit den runden M6-Kunststoffzierabdeckungen abdecken.



17 Verkabelung m/Kunststoffstützen und Flanschen an der Fahrerhausdecke befestigen und anschließen (Montagebereich vorher sorgfältig reinigen).



Explosionsansicht bis zur befestigung der befestigungsauflagen

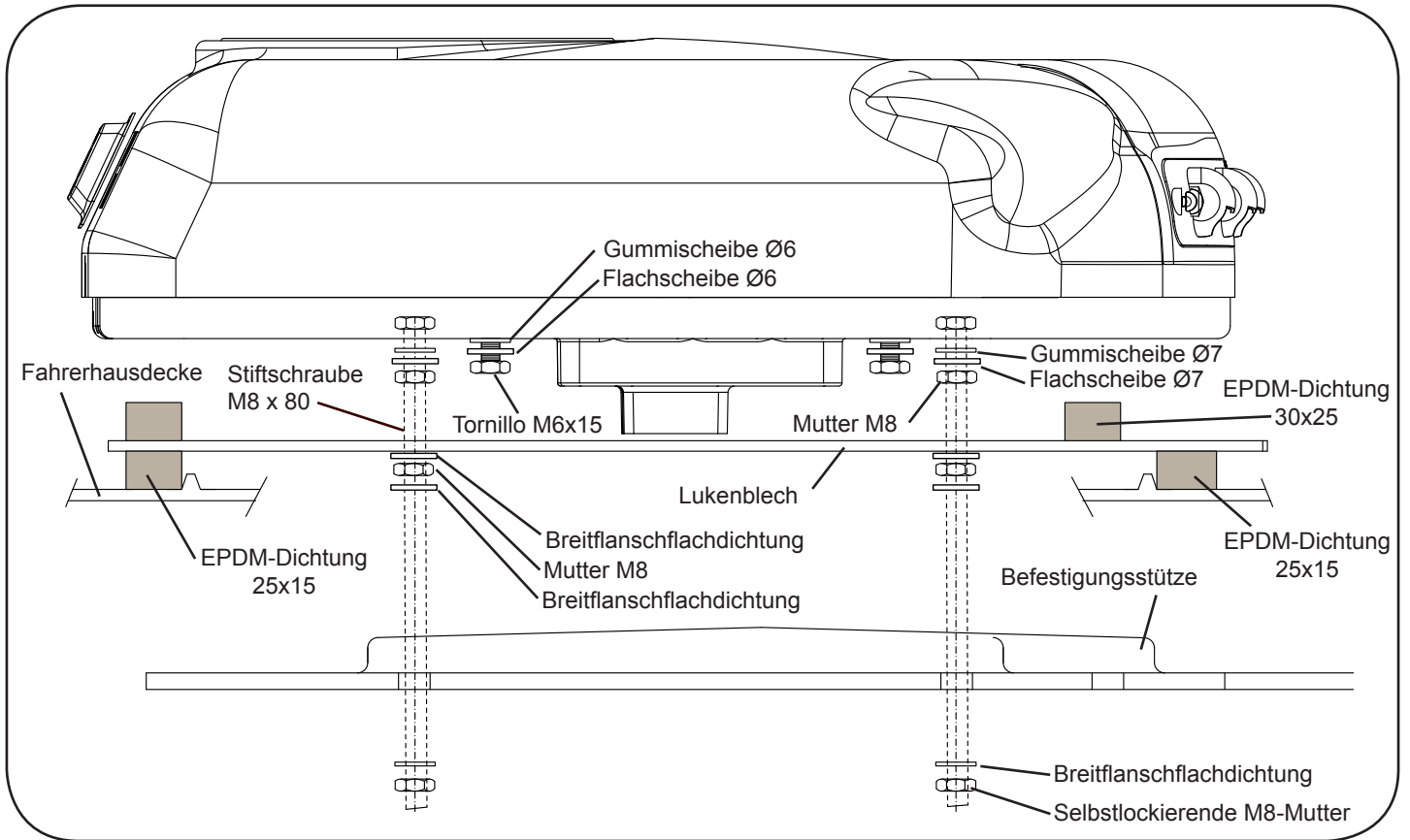

Explosionsansicht bis zur befestigung der konsolen

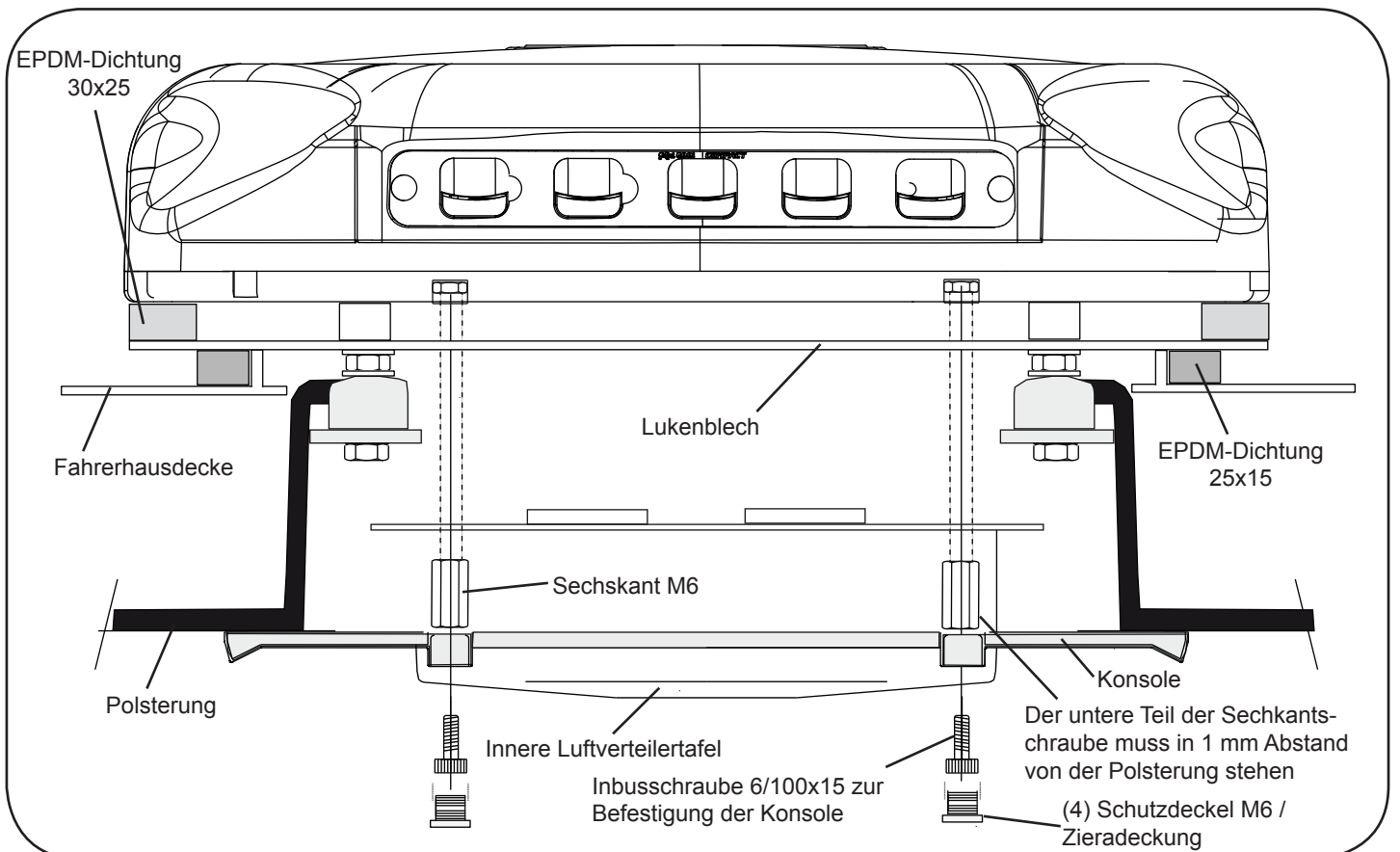

Ausführliche Einleitungen über die Installation der Verkabelungsleitung



1

Versorgungs-
verkabelung



1- Führen Sie bitte die Verkabelungsleitung der Anlage bis zur Batterie des Fahrzeugs, befestigen Sie anschliessend die Plastikhalterungen in der hinteren Seite der Kabine und klammern diese fest mit Flanschverschraubungen ; anschliessend mit der schräg offenen Kabine, führen Sie diese Verkabelung durch die untere Seite der Kabine, und befestigen Sie diese mit Klammern und M4 Schrauben - und bis zur Batterie mit Flanschverschraubungen - muss der selbe Schritt ausgeführt werden mit der Originalverkabelung. *(Um die Plastikhalterungen zu bekleben, bitte zuvor gut die zu klebende Zone dementsprechend säubern).* Beim Anschliessen der Anlage an die Batterie des Fahrzeugs wird an allen leds eine Probe durchgeführt, im Display erscheint dann **88--bd** und blendet sich wieder aus.

⚠ WICHTIGER HINWEIS: Aufgrund des komplexen elektronischen Steuerungssystems der Anlage muss die Stromversorgung direkt von der Fahrzeugbatterie oder anderer autorisierter Quelle und nicht von einem anderen Versorgungspunkt für sonstiges Fahrzeugzubehör aus erfolgen, wobei darauf zu achten ist, dass beim Anschluss die Polaritäten nicht vertauscht wird.

⚠ WICHTIG: Für die Betriebsnahme bitte lesen Sie genau die Vorschriften im Benutzerhandbuch.

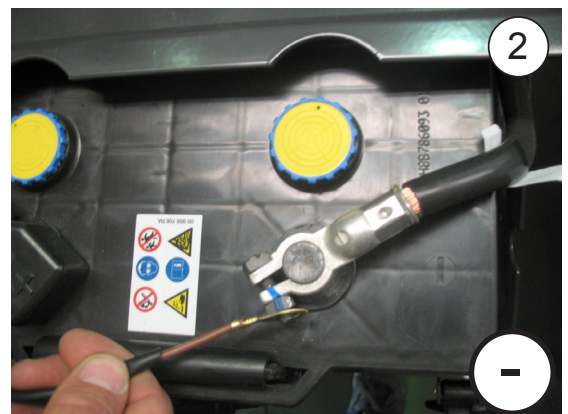

Elektrische Verkabelung

WICHTIGER WARNHINWEIS!

Achten Sie darauf, die Polaritäten beim Anschluss der Anlage an die Batterie nicht zu vertauschen. Ist dies der Fall, schaltet sich das Bedienfeld nicht ein und das Gerät funktioniert nicht.

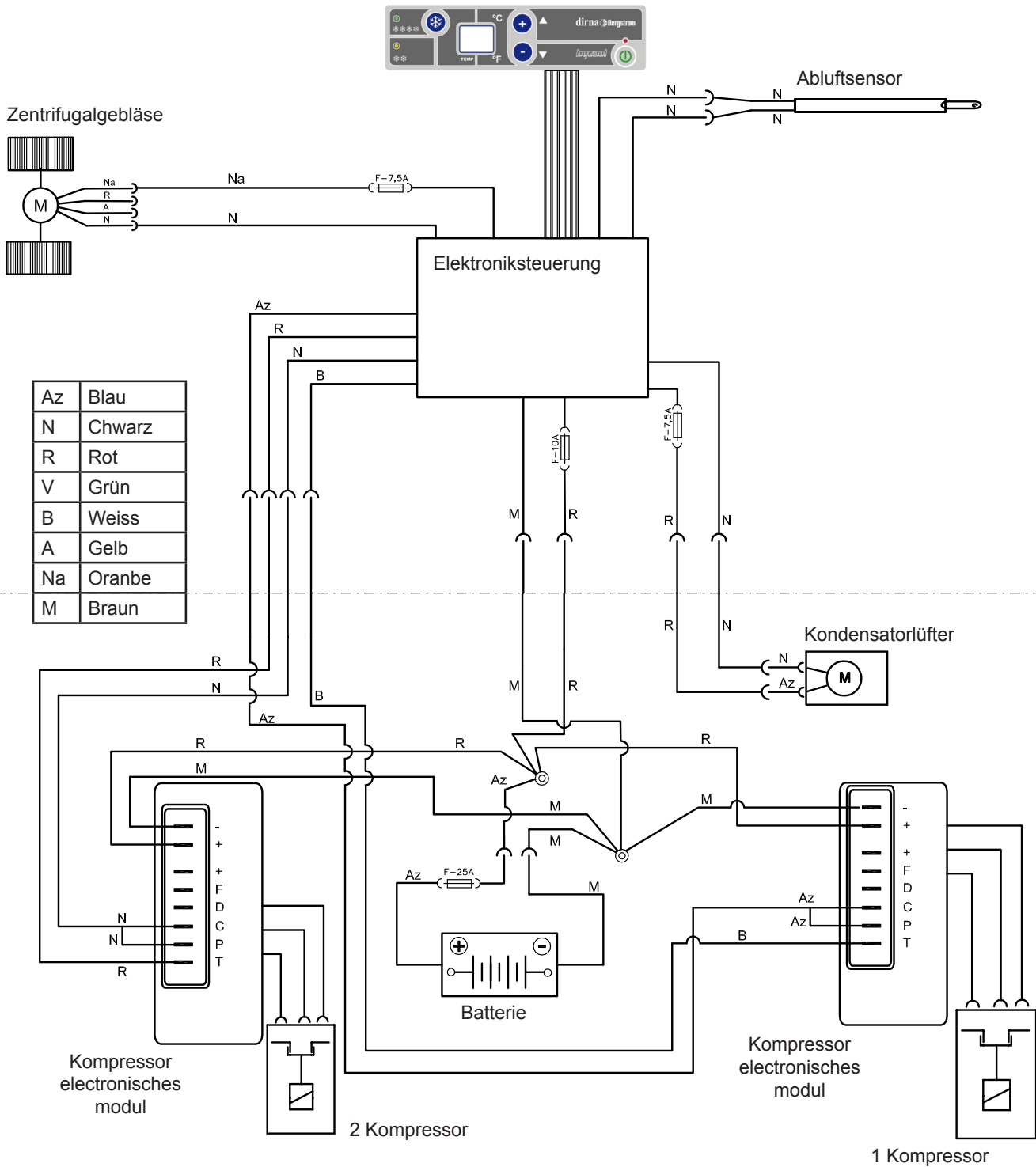

Für die Kabinen XLX mit Spoiler
An dem Spoiler vorzunehmende Modifizierungen

1 Angegebene Maße markieren, Spoiler mit Karosserieband vor Beschädigung schützen und schneiden.

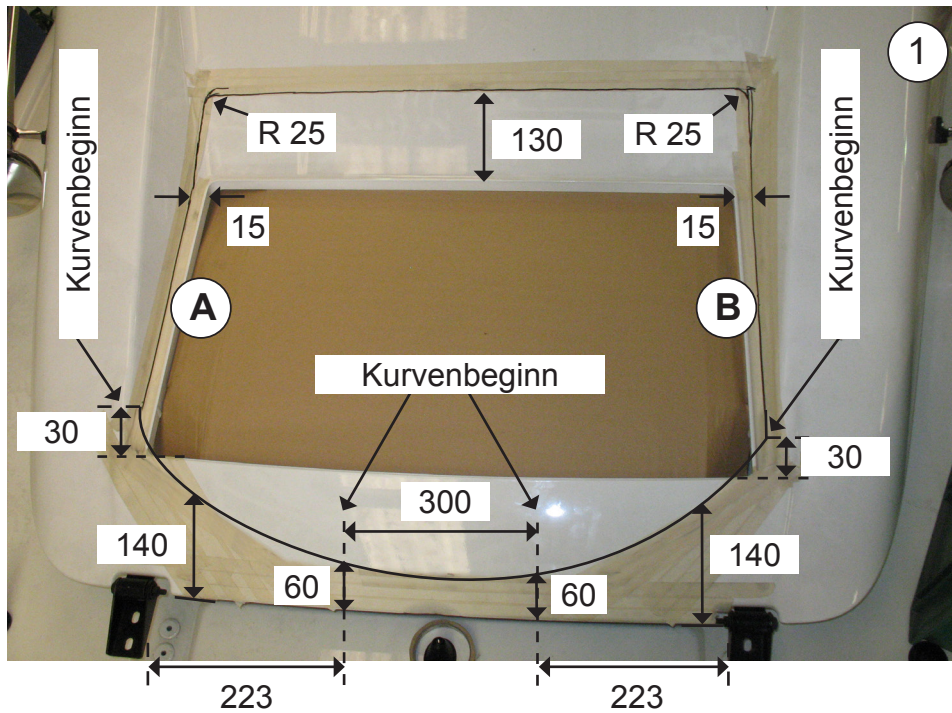

Ansicht Unterseite Spoiler

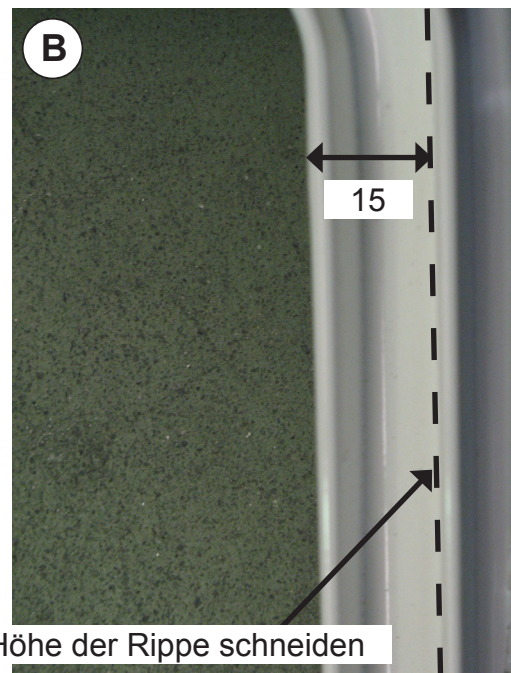
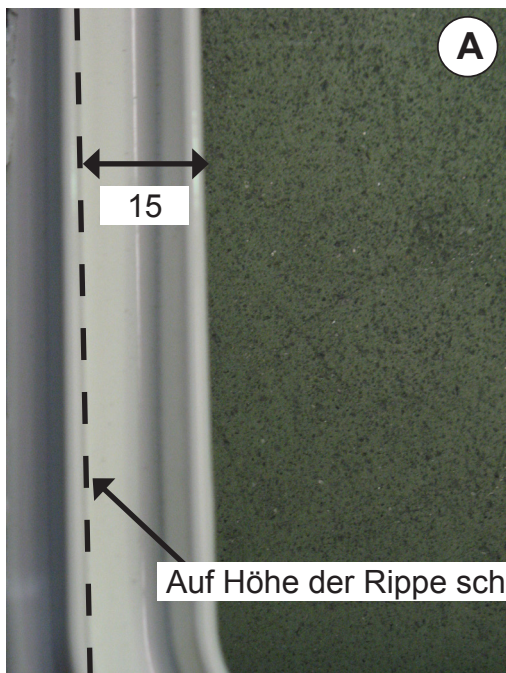

2 Spoiler mit den Originalschrauben in seiner Originalposition montieren.



Suggerimenti per il montaggio

- Prima di cominciare il montaggio, leggere attentamente le istruzioni e rispettarle nel corso dello stesso.
- Usare gli attrezzi più adatti ad ogni operazione.

Elettricità

- Scollegare la chiave di contatto.
- Scollegare la batteria prima di cominciare il montaggio.
- Assicurarsi di avere effettuato correttamente l'installazione e il collegamento dei componenti elettrici.

Attenzione

Se durante il montaggio si inclina l'impianto, prima di rimetterlo in funzione occorre attendere almeno 60 minuti dal momento in cui è di nuovo in posizione orizzontale.

Attenzione

Quando si installa l'impianto di aria condizionata sul tettuccio, bisogna proteggere la parte superiore della cabina con uno straccio o una coperta per evitare eventuali graffi. Per l'installazione del **Compact**, tenere presente che normalmente le cabine munite di oblò dispongono di una struttura abbastanza solida per sostenere il peso dell'impianto. Tuttavia, se così non fosse e se fosse necessario tagliare il tettuccio, o se in presenza di oblò la struttura non fosse abbastanza rigida (se fosse di fibra, plastica, ecc.), è responsabilità dell'installatore decidere se occorre rinforzare il tettuccio per evitare qualsiasi deformazione, rottura o penetrazione d'acqua, ecc., prendendo le misure necessarie per evitarlo.

Attrezzi

Kit di chiavi Torx
 Kit di chiavi Allen
 Chiave fissa 10, 13, 14
 Forbici
 Metro a nastro

Documentazione allegata

Istruzioni di montaggio	220.AA3.3080
Guida dell'utente	220.AA6.0170
Soluzione dei problemi	220.AA6.0013
Parti fornite	220.RE0.0121
Garanzia	220.AA1.0017

Avvertenze

 L'installatore deve essere in possesso della formazione necessaria in materia di aria condizionata per veicoli.

 **dirna Bergstrom, s.l.** declina ogni responsabilità per danni o rotture derivanti dall'errata installazione o dall'errato uso dell'impianto o da sostituzioni o modifiche effettuate senza la necessaria autorizzazione per iscritto.

 **Impianto precaricato con gas refrigerante. (Non manomettere il circuito di gas refrigerante).**

 Vedi la **procedura di garanzia** del prodotto in **Diagnosi dei problemi**.

 Vedi la **Guida dell'utente** dell'impianto per il corretto funzionamento del telecomando e del pannello di controllo.

 I seguenti documenti devono essere consegnati all'utente una volta conclusa l'installazione: **Guida dell'utente, Garanzia e Diagnosi dei problemi**.

 Prima di iniziare il montaggio, installare la griglia sull'entrata anteriore dell'aria.



 Per i veicoli **TGX cabina XLX con spoiler**, le modifiche da eseguire sul medesimo devono essere autorizzate dal cliente. **Dirna Bergstrom declina perciò ogni responsabilità** per la modifica dello spoiler. In caso di autorizzazione all'esecuzione delle modifiche allo spoiler, occorre smontarlo prima di cominciare l'installazione.

1 Smontare lo spoiler. Smontare il coperchio del tettuccio apribile, gli elementi di fissaggio e consegnarli al cliente.



2 Rimuovere i residui eventualmente rimasti attaccati al tetto prima di incollare la guarnizione EPDM.

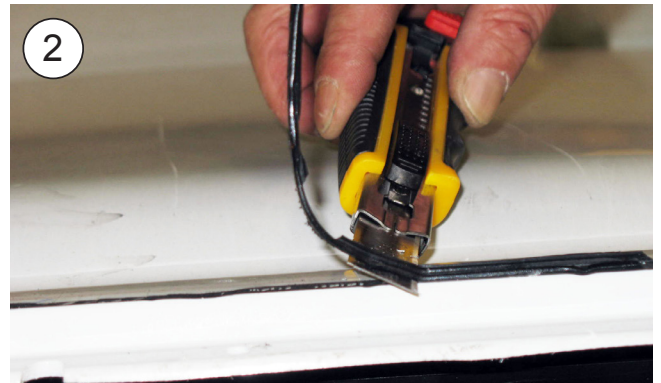
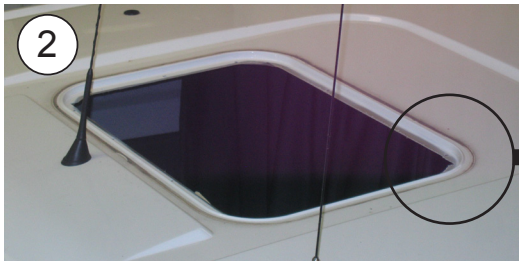

3 Incollare la guarnizione EPDM 25x15 intorno alla sporgenza del vano del tettuccio apribile (vedi il particolare per tagliare i bordi finali di unione della guarnizione).

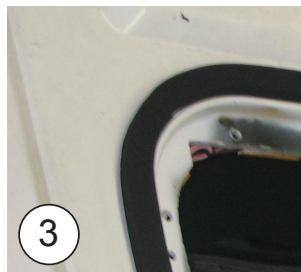

COME TAGLIARE LA GUARNIZIONE EPDM PER EVITARE L'INFILTRAZIONE DELL'ACQUA NELLA CABINA

- A-** Incollare la guarnizione, lasciando 100 mm di carta protettiva su ogni lato.
- B-** Rimuovere i due pezzi di carta.
- C-** Incollare premendo entrambe le estremità.

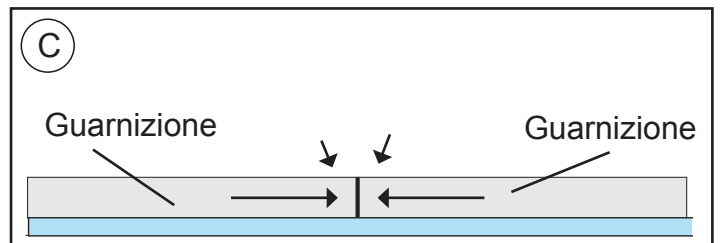
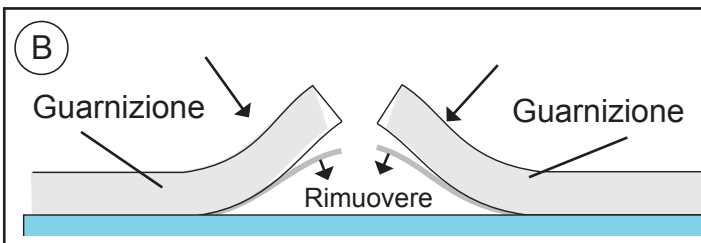
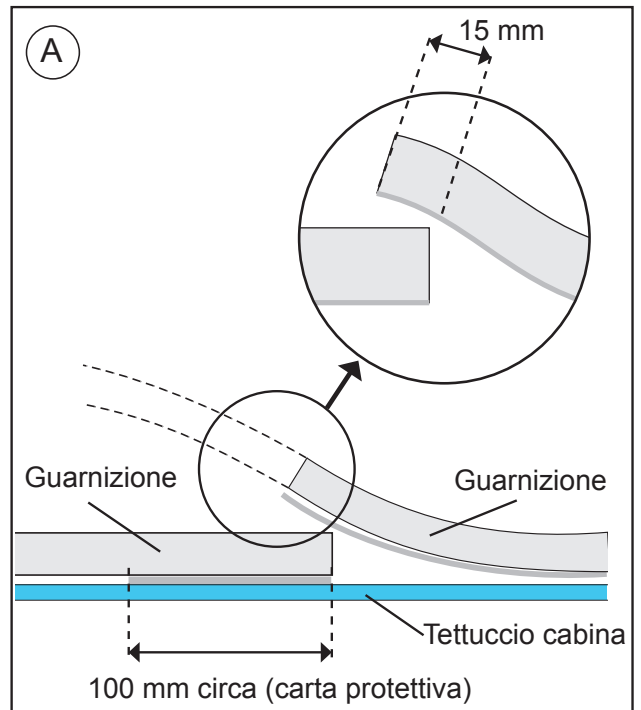

4 Avvitare di 10 mm (4) viti prigioniere M8x85 sulla base Compact e su queste ultime inserire (1) rondella di gomma Ø 20 x Ø 7 x 3, (1) rondella piana Ø 6 e (1) dado M8. Stringere contro la base.

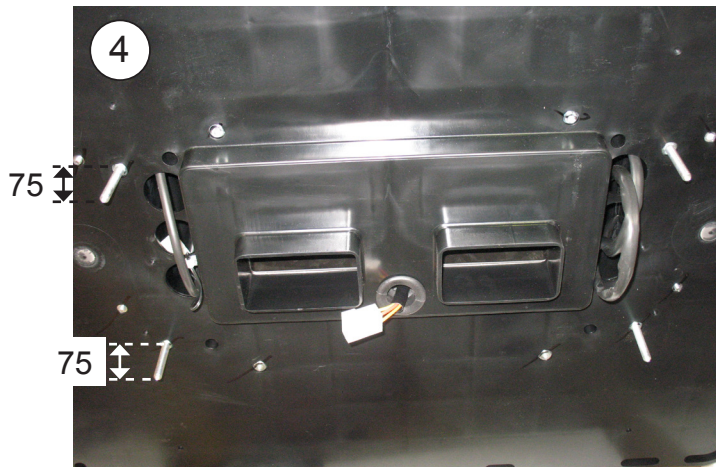

TGA / TGX cabina modello XLX con spoiler

⚠ **Attenzione:** Per l'installazione di questo modello è necessario effettuare modifiche allo spoiler, che devono essere autorizzate dal cliente. **Dirna Bergstrom declina ogni responsabilità per la modifica dello spoiler.**

5 Incollare come indicato la guarnizione EPDM 30x25 sulla lamiera del tettuccio apribile.
ATTENZIONE: pulire prima la lamiera per assicurare l'adesione della guarnizione EPDM.

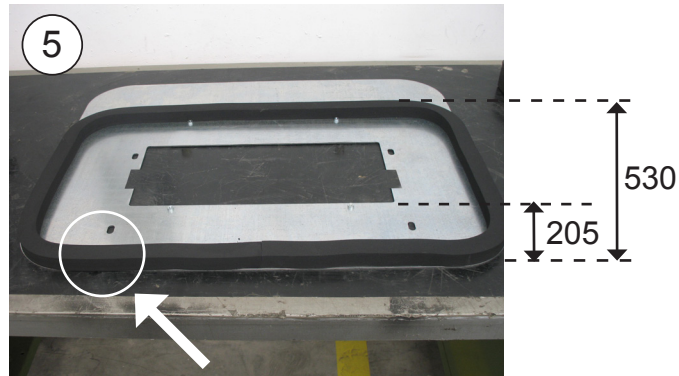

Montaggio della parte posteriore dell'impianto posizionare sul bordo

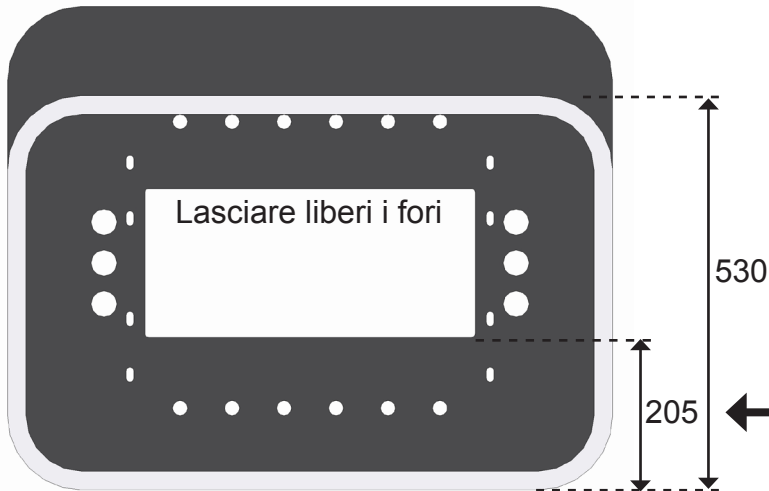

⚠ Attenzione alla misura

TGA / TGX cabina modelo XLX/XXL sin spoiler

5a Incollare la guarnizione EPDM 30x25 come indicato.

Attenzione: pulire prima la lamiera per assicurare l'adesione della guarnizione EPDM.

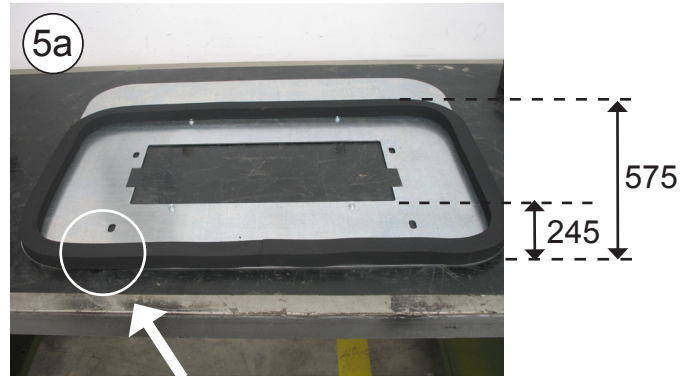
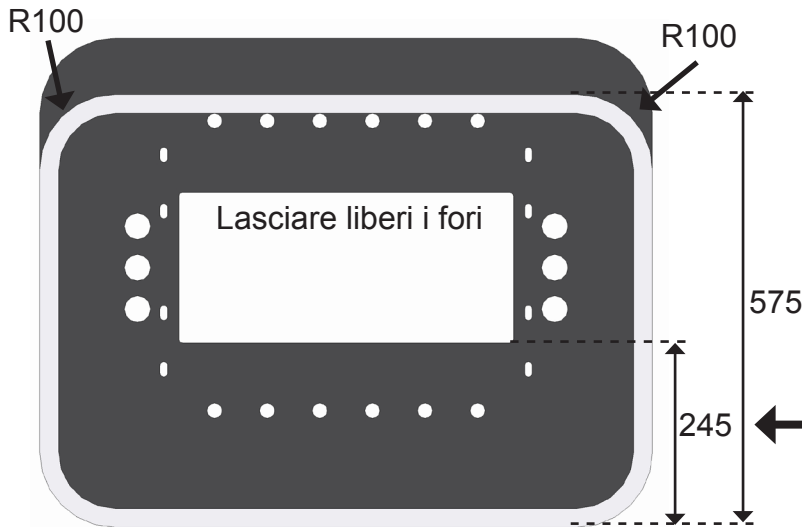

Montaggio della parte posteriore dell'impianto posizionare sul bordo

⚠ Attenzione alla misura

6 Sistemare l'impianto sulla lamiera del tettuccio apribile, inserendo le viti prigioniere nei fori della lamiera indicati in 6a e 6b.

ATTENZIONE! Quando si posiziona l'impianto sul vano del tettuccio apribile, controllare che le uscite di scarico non siano ostruite dalla guarnizione EPDM.



TGA / TGX cabina modello XLX con spoiler



Attenzione: Per l'installazione di questo modello è necessario effettuare modifiche allo spoiler, che devono essere autorizzate dal cliente. Dirna Bergstrom declina ogni responsabilità per la modifica dello spoiler.

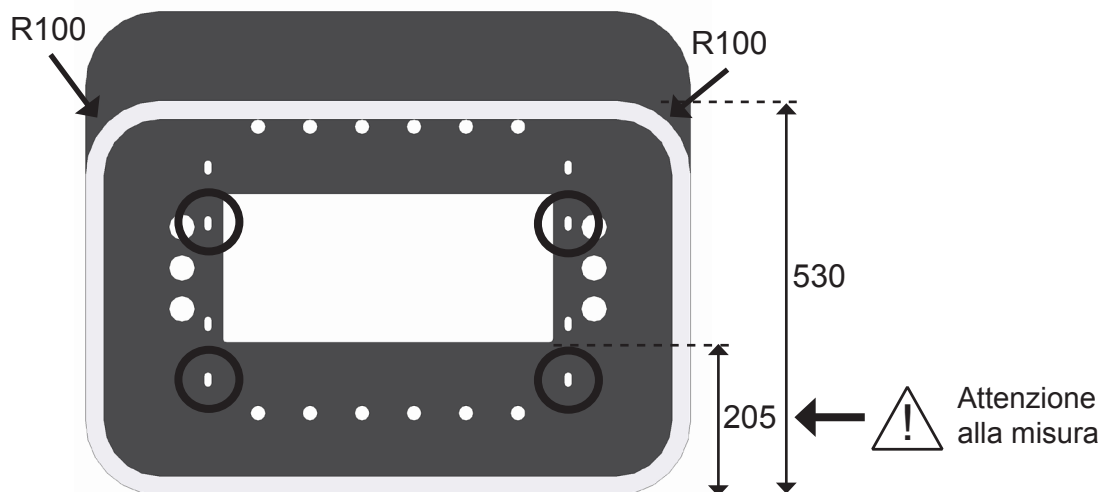

TGA / TGX cabina modello XLX/XXL senza spoiler

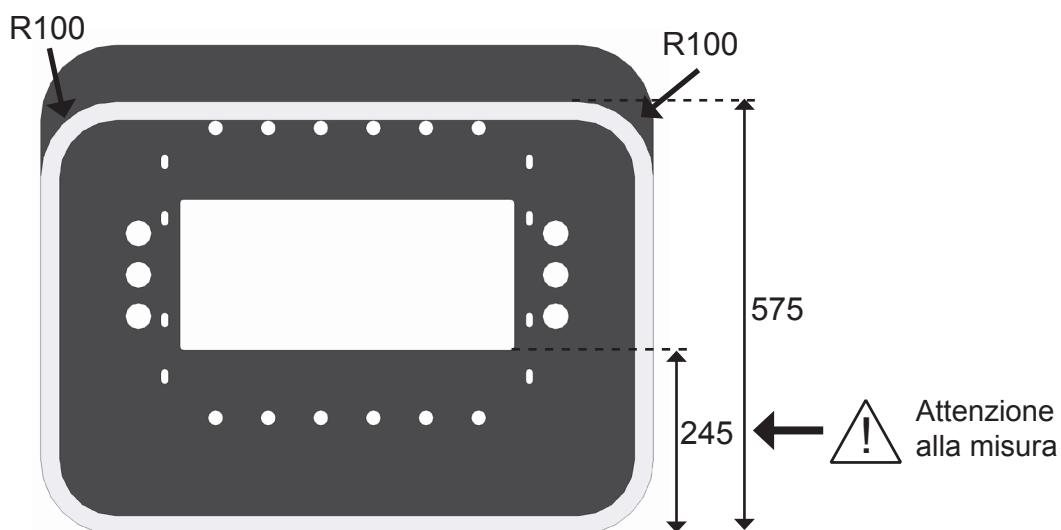

- 7** Inserire (1) rondella piana e (1) dado in ogni vite prigioniera e stringere fino a battuta la lamiera con i dadi di fissaggio delle viti prigioniera alla base.

- 8** Inserire l'impianto con la lamiera nel vano del tettuccio apribile del veicolo dalla parte anteriore: **la lamiera del tettuccio apribile deve restare a filo della guarnizione EPDM.**



- 9** Dalla parte interna centrare lateralmente l'impianto nel vano del tettuccio apribile.

⚠ **Nota bene:** se la guarnizione (A) non è incollata alla base, rimuovere la carta protettiva della stessa e incollarla come indicato.

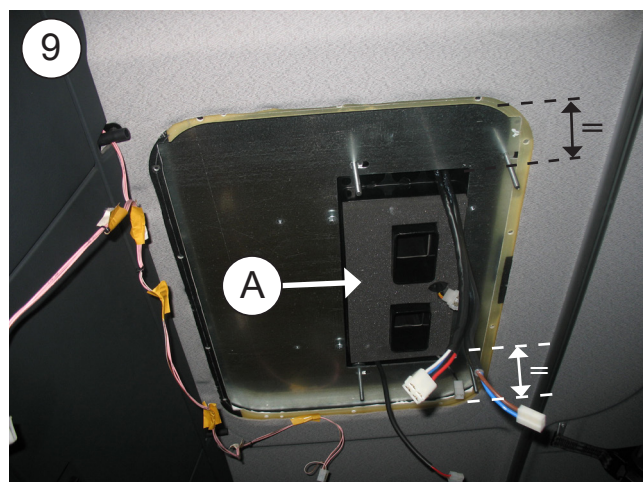

- 10** Incollare i canalizzatori sul pannello interno di distribuzione dell'aria.

⚠ **Nota bene:** se è presente il set di canalizzatori (B), questi ultimi devono essere scartati poiché non sono validi per questo impianto.

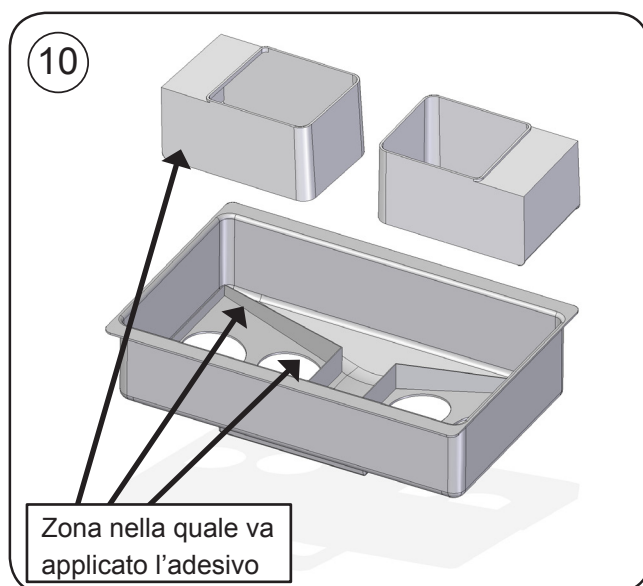

- 11** Tra l'impianto e il pannello interno di distribuzione dell'aria, collegare le (2) scatole a 4 vie, le (2) scatole a 2 vie e collegare il cablaggio di alimentazione alla scatola a 2 vie a forma di "T".

ATTENZIONE: È molto importante non invertire i colori della scatola a 2 vie del ventilatore del condensatore (scatola con cavi R e N).



- 12** Inserire il pannello interno di distribuzione dell'aria sulle viti prigioniere più vicine ai vani portaoggetti anteriori sulla lamiera e fissare con i perni esagonali M6x25. (**Attenzione:** evitare che i cablaggi restino impigliati tra i canalizzatori e l'impianto).

ATTENZIONE: sistemare il pannello interno di distribuzione dell'aria in modo tale che i canalizzatori siano a battuta con la guarnizione della base dell'impianto.

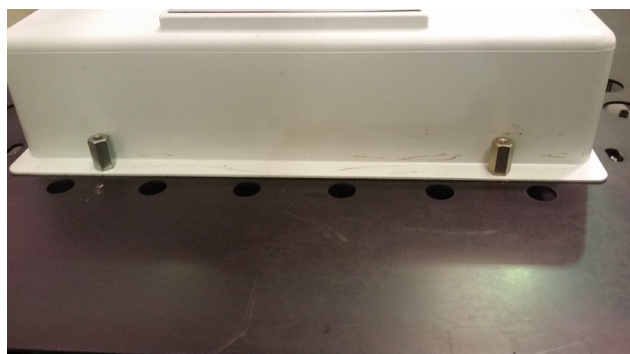

- 12a** Sistemare provvisoriamente la console e centrare l'impianto in modo tale da situarlo nel punto in cui era ubicata la console originale.



- 13** Inserire i supporti sulle viti prigioniere M8, fissare con le rondelle Ø8 a testa larga e il dado M8 autobloccante e stringere finché il supporto non è a contatto con la lamiera nella parte centrale.

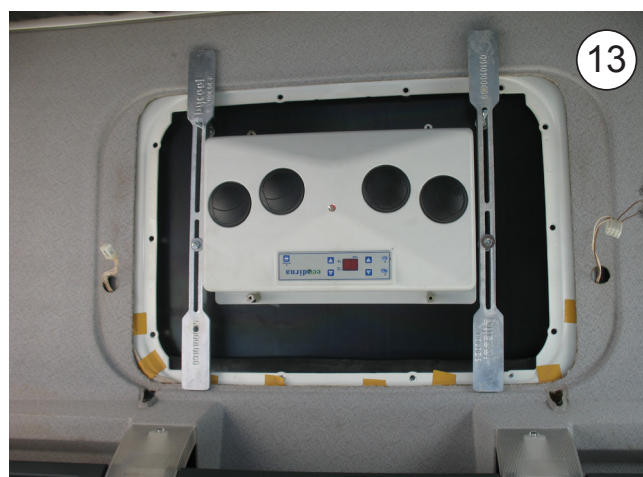

- 14** Fissare la console con (4) viti a brugola M6/100x15.

 **ATTENZIONE:** estrarre i cablaggi originali



15 Collegare e montare le luci originali nelle console.



16 Coprire le (4) viti M6/100x15 a brugola con gli elementi decorativi rotondi M6 di plastica.



17 Collegare e fissare il cablaggio con i supporti di plastica e le flange al tettuccio della cabina (pulire bene la zona prima di farlo).



Esploso fino al fissaggio dei supporti di fissaggio

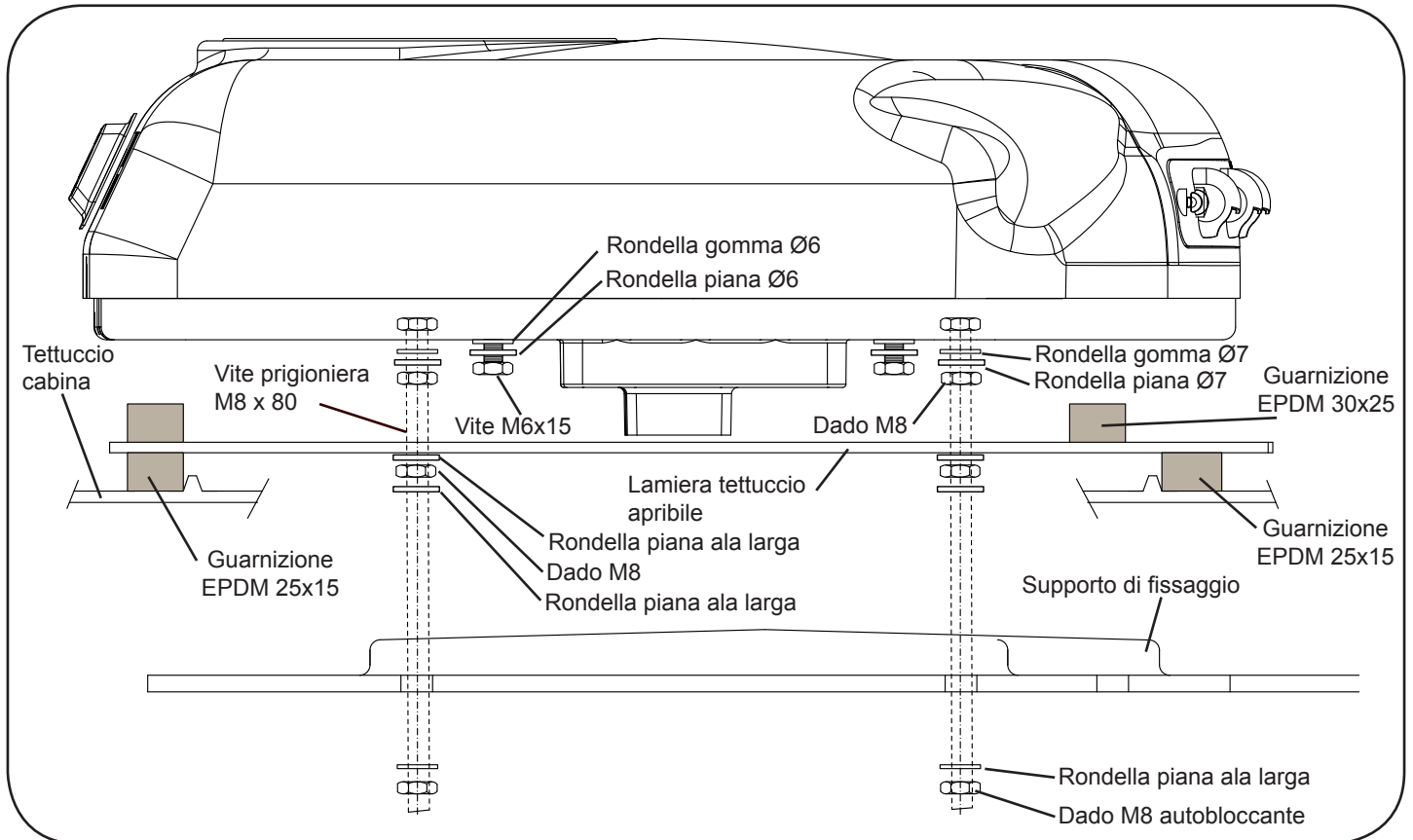

Esploso fino al fissaggio della consolle

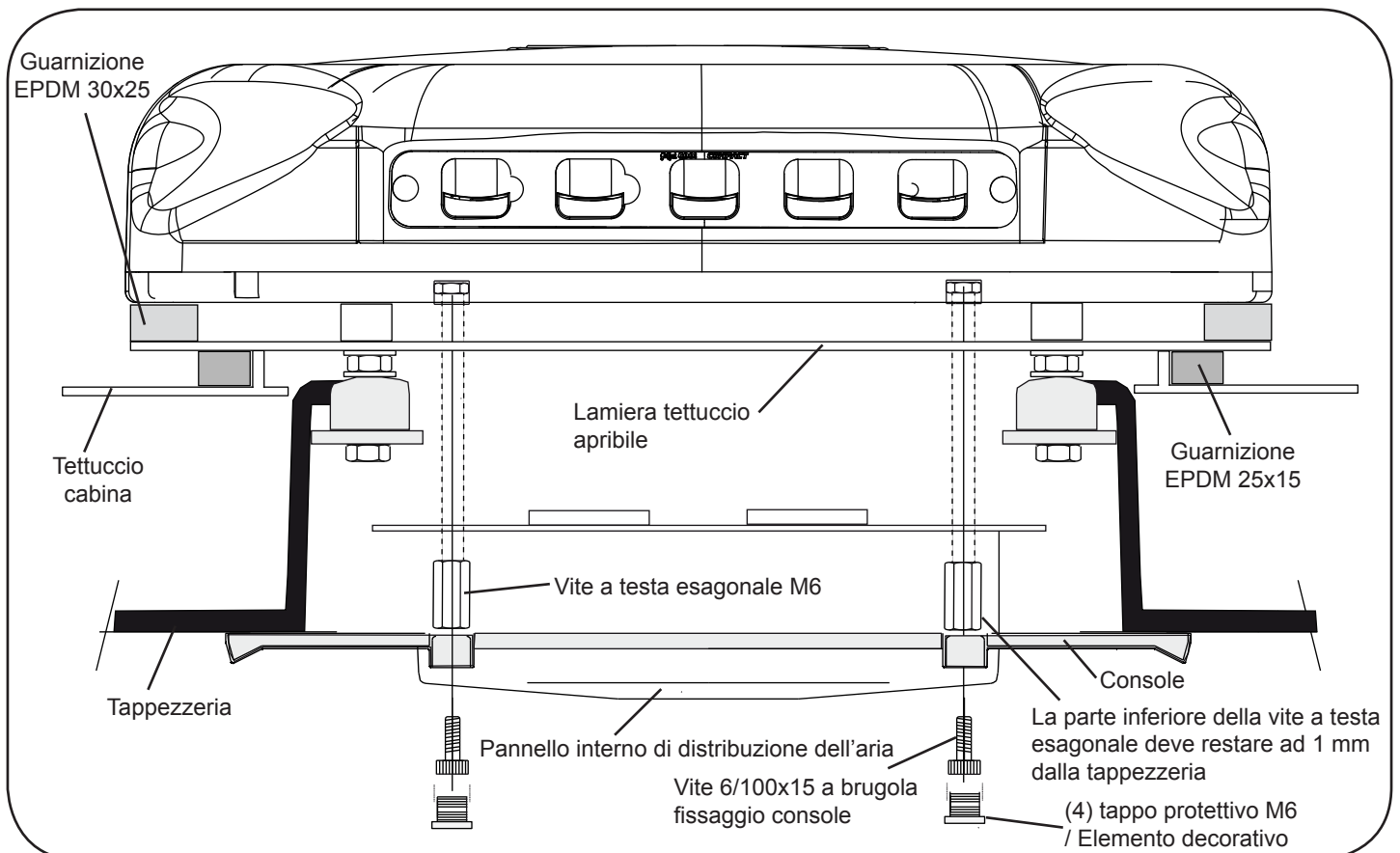

Istruzioni dettagliate Sull'installazione del cablaggio di alimentazione

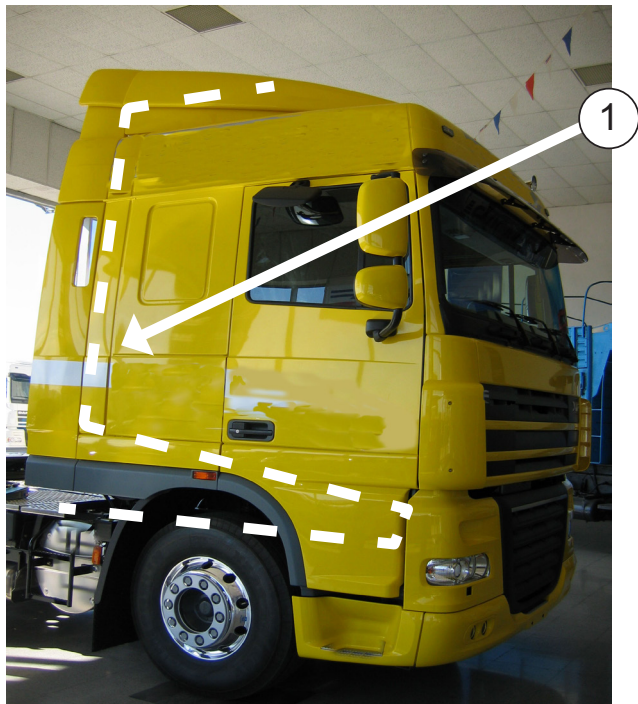

Cablaggio dell'alimentazione



1- Portare il cavo dell'alimentazione dall'apparecchiatura fino alla batteria del veicolo, collocando i supporti in plastica sulla parte posteriore della cabina e fissandoli con flange; dopo con la cabina riversata passare il cavo dalla sua parte inferiore bloccandolo con fascette e viti M4; ma fino alla batteria con flange; si dovrà usare lo stesso passo del cablaggio originale. *(Per collocare i supporti in plastica prima bisogna pulire per bene la zona di adesione)*. Collegando l'apparecchiatura alla batteria si effettuerà un test in tutti i suoi leds, apparirà sul display **88--bd** e si spegnerà.

⚠ **NOTA BENE:** dato il complesso sistema di regolazione elettronica dell'impianto, la corrente deve essere presa direttamente dalla batteria del veicolo o dal punto autorizzato e non da qualsiasi altro che eroga ad altri accessori del veicolo, facendo attenzione a non invertire la polarità effettuando la connessione.

⚠ **IMPORTANTE:** per la messa in funzionamento si dovrà consultare il Manuale dell'Utente.



Cablaggio elettrico

AVVISO IMPORTANTE!

Fare attenzione a non invertire le polarità quando si esegue il collegamento dell'impianto alla batteria. Infatti, in tal caso il quadro comandi non si accende e l'impianto non funziona.

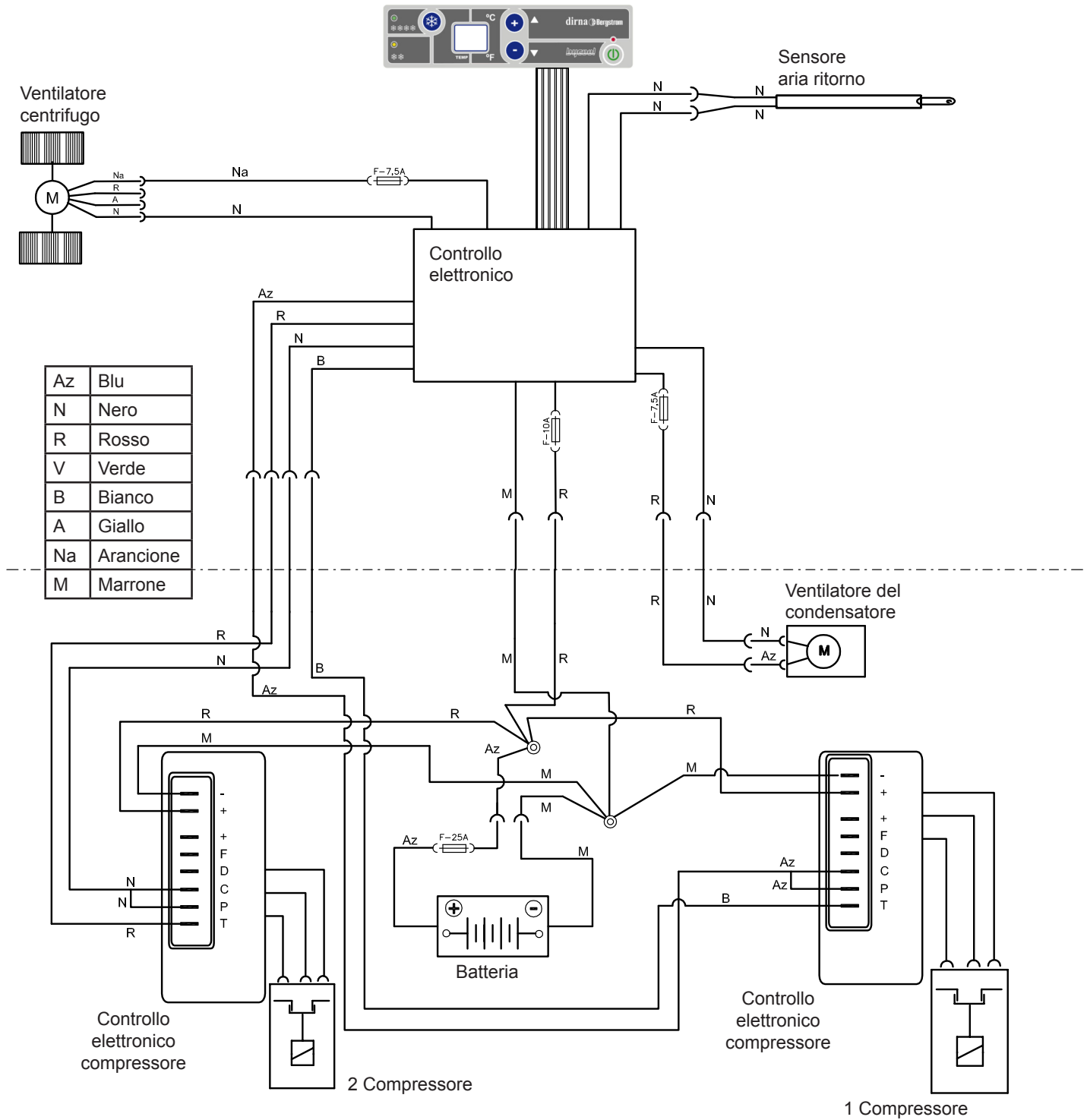

Per cabine XLX con spoiler
Modifiche da eseguire sullo spoiler

1 Segnare le misure indicate, proteggere con nastro da carrozziere per non danneggiare lo spoiler ed eseguire il taglio.

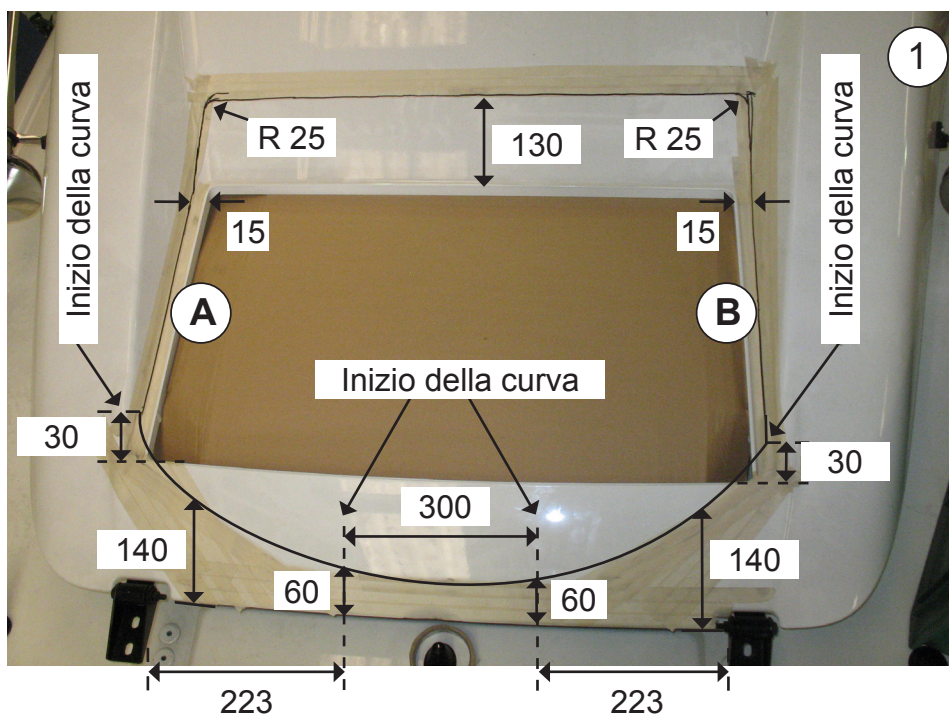

Vista dalla parte inferiore dello spoiler

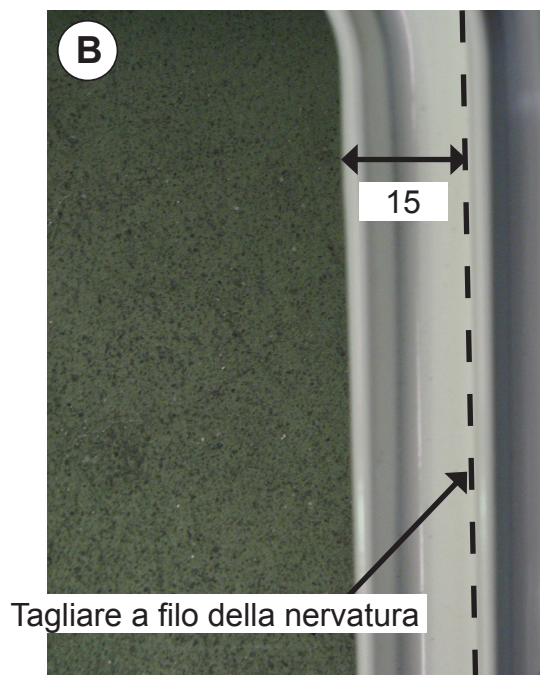
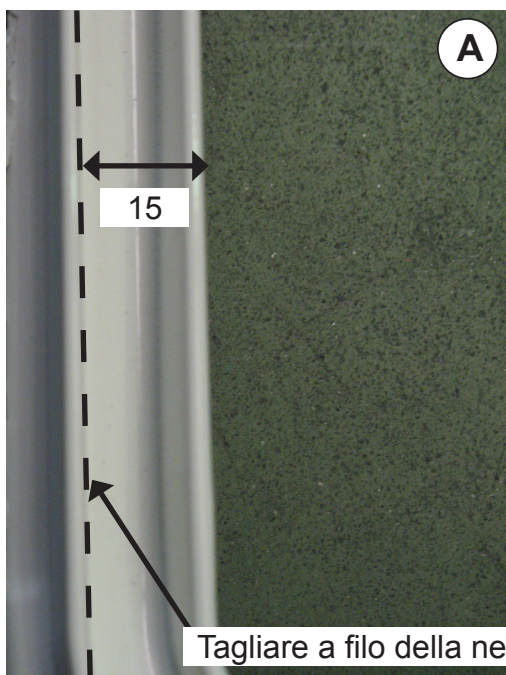

2 Montare lo spoiler con le viti originali nella posizione originale.



Ed:	26/07/2012
Md:	22/07/2019

1



Francisco Alonso, 6
28806 Alcalá de Henares, Madrid
SPAIN

Contact	Phone	Fax	E-Mail
Sales (Ventas Internacional)	+34 91 8770510	+34 91 8771158	sales@dirna.bergstrominc.com
Comercial Nacional	+34 91 8775841	+34 91 8836321	ventas@dirna.bergstrominc.com
Orders & Deliveries (Logística internacional)	+34 91 8775846	+34 91 8771158	export@dirna.bergstrominc.com
Orders & Deliveries (Logística nacional)	+34 91 8775840	+34 91 8836321	comercial@dirna.bergstrominc.com
Technical Assistance (Internacional)	+49 511 86679681	+49 511 86679710	technicalassistance@dirna.bergstrominc.com
Technical Assistance (Nacional)	+34 91 8775845	+34 91 883 6321	oblanco@dirna.bergstrominc.com

www.dirna.com

	ATENCIÓN:	Dirna Bergstrom se reserva el derecho de efectuar modificaciones en cualquier momento de los datos contenidos en esta publicación, por razones técnicas o comerciales.
	NOTE:	<i>For technical and commercial reasons, Dirna Bergstrom reserves the right to change the data contained in this brochure.</i>
	ATTENTION:	Dirna Bergstrom se réserve le droit d'effectuer à tout moment des modifications des données reprises sur cette publication, pour des raisons techniques ou commerciales.
	HIWEIS:	<i>Dirna Bergstrom behält sich vor, aus technischen oder kaufmännischen Gründen jederzeit Änderungen der Angaben dieser Veröffentlichung vorzunehmen.</i>
	ATTENZIONE:	Dirna Bergstrom si riserva il diritto di effettuare modifiche in qualsiasi momento ai dati contenuti in questa pubblicazione, per motivi tecnici o commerciali.