

bycool!
green line

COMPACT 1.4



Mercedes-Benz

Actros MP4

(chassis WDB963)



Instrucciones de Montaje

Mounting Instructions

Instructions de Montage

Montageanweisungen

Istruzioni di Montaggio

ES Spanish

EN English

FR French

GE German

IT Italian

Recomendaciones Para el montaje

- Antes de iniciar el montaje leer las instrucciones y seguirlas durante el proceso de instalación.
- Usar las herramientas adecuadas para cada operación.

Electricidad

- Desconectar la llave de contacto.
- Desconectar la batería antes de empezar el montaje.
- Asegurar el conexionado de los componentes eléctricos, verificando su correcto encaje.

Atención

Si durante el montaje el equipo se inclina, se deberá esperar un mínimo de 60 minutos desde que el equipo quede en posición horizontal antes de ponerlo en funcionamiento.

Atención

Al instalar el equipo de aire acondicionado en el techo se debe proteger la parte superior de la cabina con un paño o manta protectora para evitar posibles arañazos. Al instalar **Compact** en el techo hay que tener en cuenta que, normalmente, las cabinas que vienen provistas de escotilla, tienen una estructura suficiente para soportar el peso del equipo. Sin embargo, cuando no ocurra así y sea necesario realizar corte en el techo o incluso si en el caso de llevar escotilla el material no es lo suficientemente resistente (caso de techo de fibra, plástico, etc...) es el instalador el que debe decidir, **bajo su responsabilidad**, sobre la necesidad de reforzar el techo para evitar posibles deformaciones, roturas, entradas de agua, etc... habilitando los medios para que esto no ocurra.

Herramientas

- Juego de Llaves Torx
- Juego de Llaves Allen
- Llave fija 10, 13, 14
- Tijeras
- Flexómetro





Documentación relacionada

Instrucciones de montaje	1001207475
Listado de recambios	220RE00126
Manual del usuario	220AA60170
Diagnóstico de averías	220AA60013
Garantía	220AA10017

Simbología

-  Frágil
-  Atención corte!
-  Riesgo eléctrico

Advertencias

-  El personal instalador debe poseer una formación suficiente en Aire Acondicionado de vehículos.
-  **dirna Bergstrom, s.l.** queda exenta de responsabilidad si se producen averías que procedan de una inadecuada manipulación o instalación del equipo, ó por modificaciones y sustituciones efectuadas sin nuestra expresa autorización por escrito.
-  **Equipo precargado con gas refrigerante. (No manipular el circuito de gas refrigerante).**
-  Véase **procedimiento de garantía** del producto incluido en **Diagnóstico de Averías**.
-  Véase **Manual de Usuario** del equipo para el correcto funcionamiento del mando a distancia y del panel de control.
-  Al finalizar la instalación se debe entregar al usuario: **Manual del Usuario, Garantía y Diagnóstico de averías**.

 Antes de empezar con el montaje, montar rejilla entrada aire delantera.



1 Desmontar escotilla y los elementos de fijación y entregar éstos al cliente.

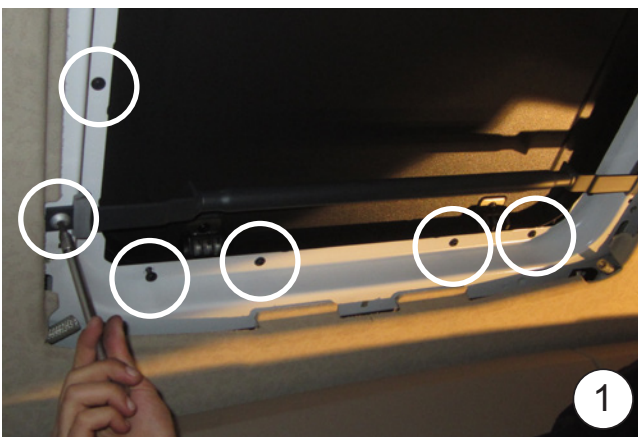
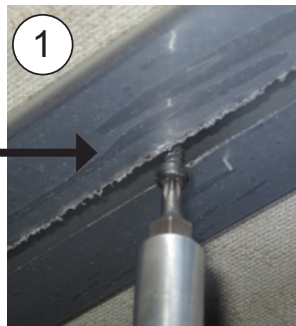
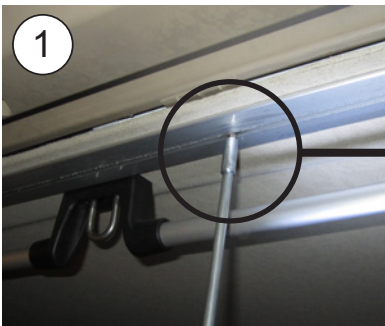
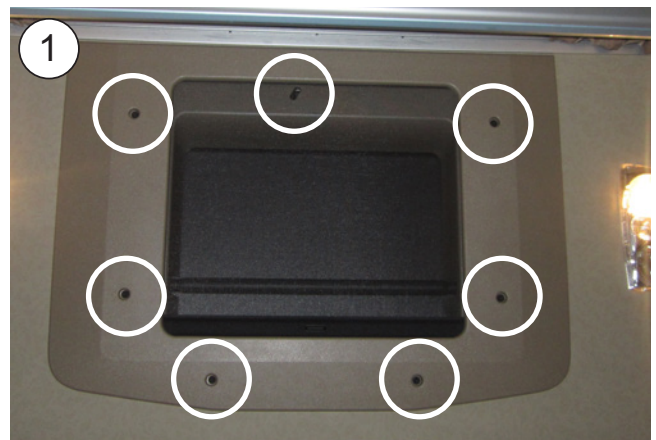
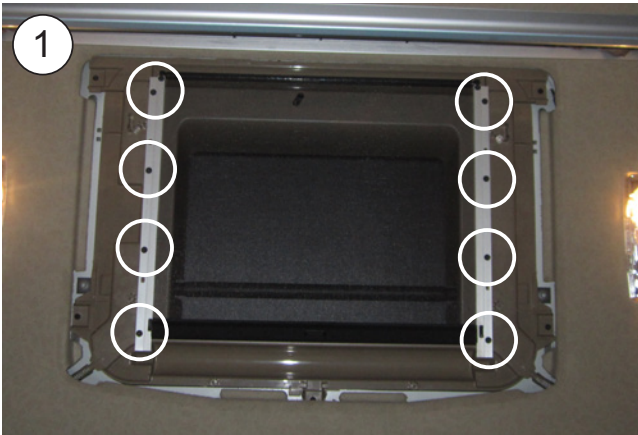

2 Pegue la junta EPDM alrededor del hueco de escotilla (mirar el detalle para cortar los bordes finales de unión de la junta).

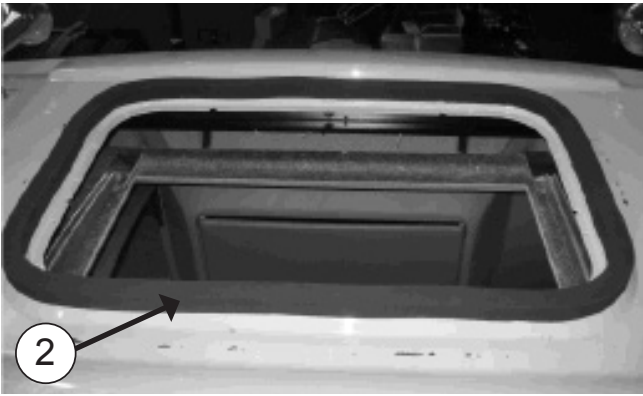

 **COMO CORTAR LA JUNTA EPDM PARA EVITAR FILTRACIÓN DE AGUA EN LA CABINA**

A- Pegar la junta, manteniendo 100 mm de papel protector por cada lado.

B- Quitar los dos piezas de papel.

C- Pegue presionado ambos finales.

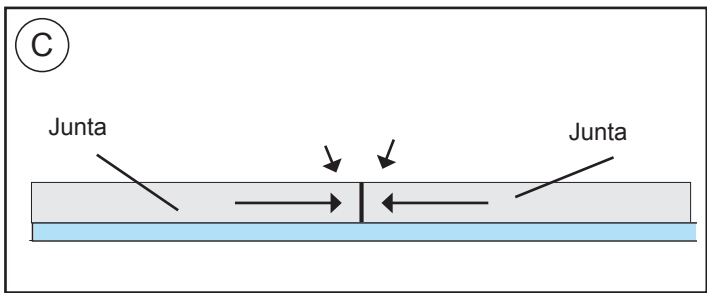
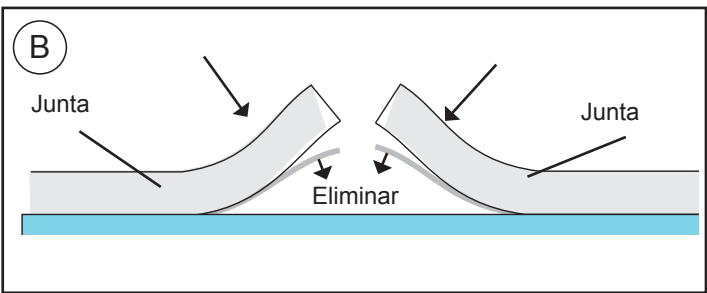
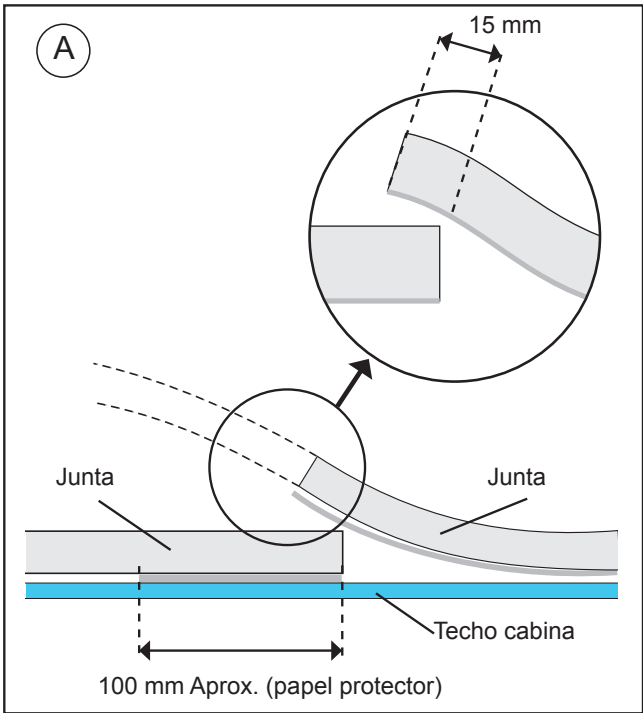

3 EXTERIOR CABINA:

Posicionar el Compact en el hueco de la escotilla.

¡Atención! Al colocar el equipo encima del hueco escotilla, revisar que las salidas de desagüe no queden obstruidas por la junta EPDM.

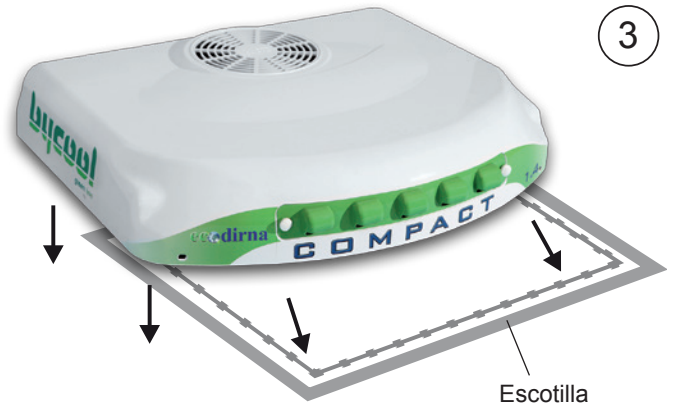

3

4 Colocar canalizador gomaespuma quedando la parte más blanda en la base del equipo.

Atención: Dependiendo de la cabina, es posible que sea necesario usar los (2) canalizadores suministrados para que el panel de distribución de aire quede totalmente ajustado con ellos.

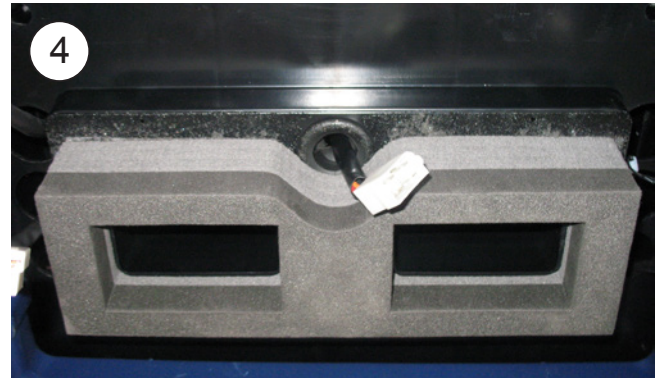

5 Colocar (4) arandelas Ø 6 de goma, (4) arandelas planas Ø 6 ala ancha sobre hexágonos L=43. A continuación apretar hexágonos hasta que la arandela de goma quede un poco oprimida.

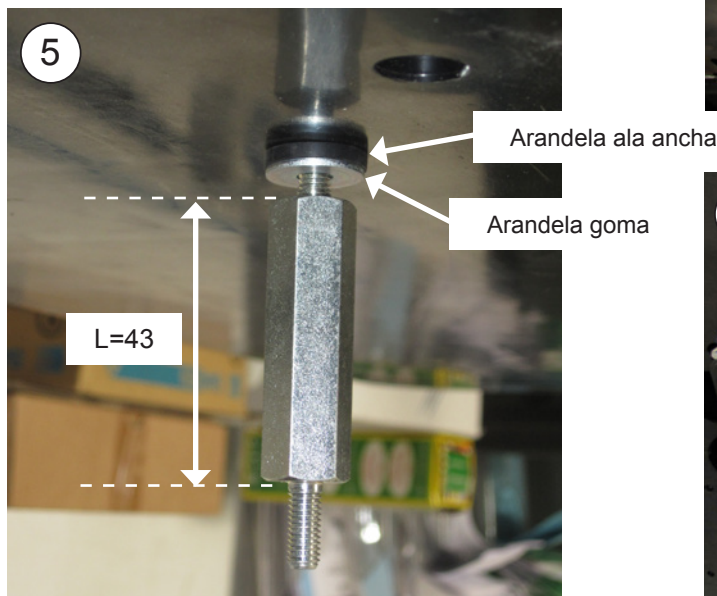
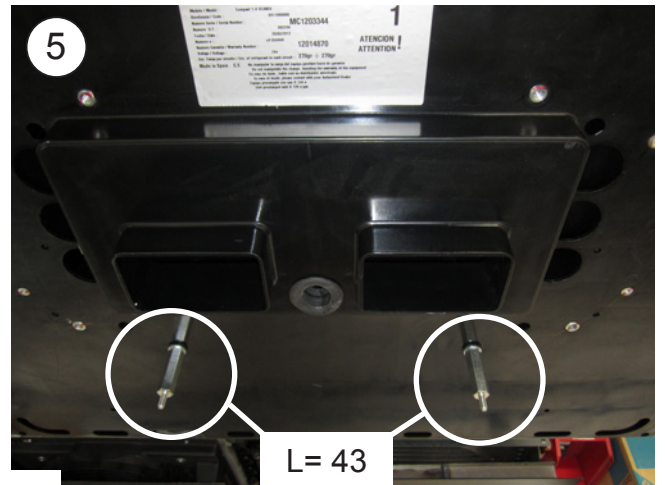

6 Conectar la caja de 2 vías del sensor del aire de retorno, la caja de 4 vías del soplador y la de 8 vías de conexión de los cableados del control electrónico.

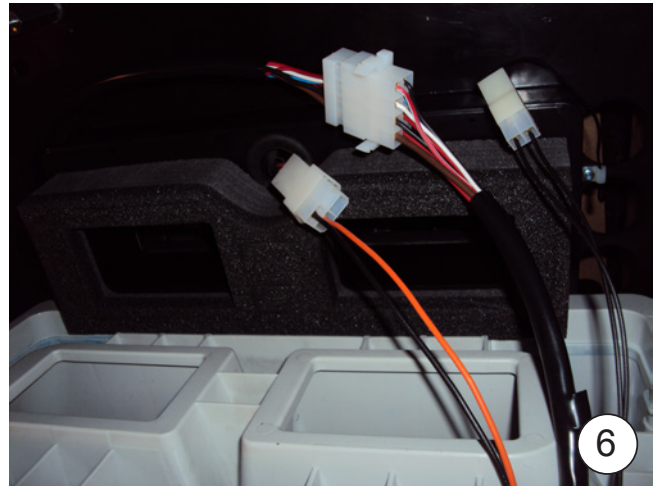

7 Colocar el panel interior de distribución de aire en los hexágonos M-M anteriores y fijar con (4) tuercas M6 con arandela y (4) hexágonos H-H L=64.

Importante: El canalizador de gomaespuma debe hacer tope contra la goma espuma superior del equipo para evitar fugas de aire.

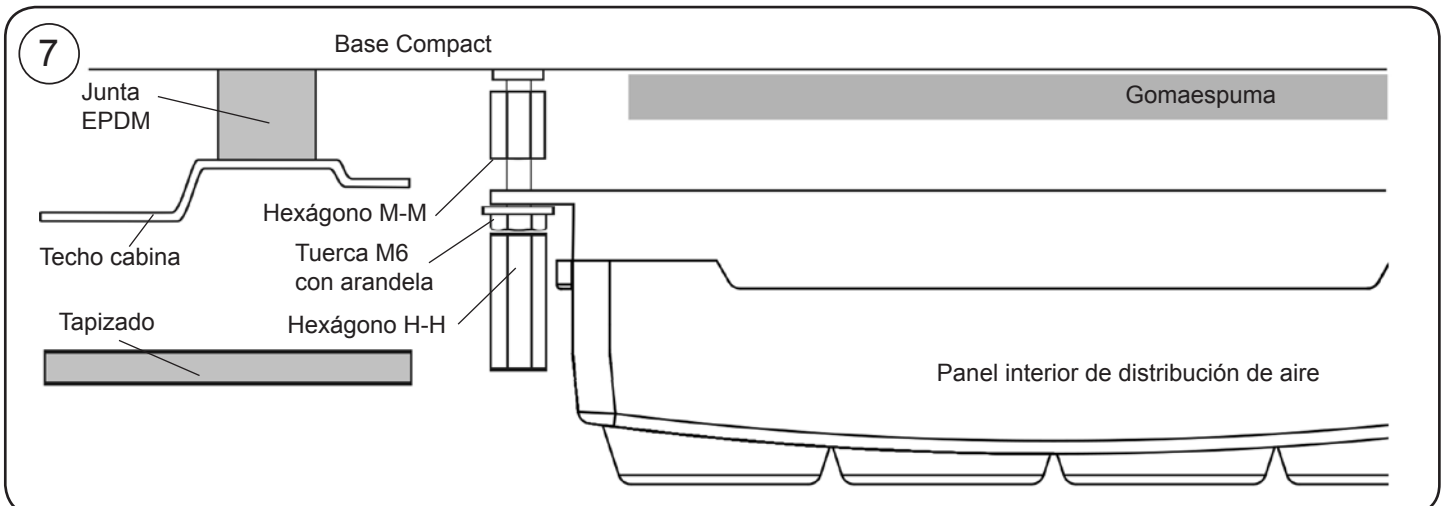
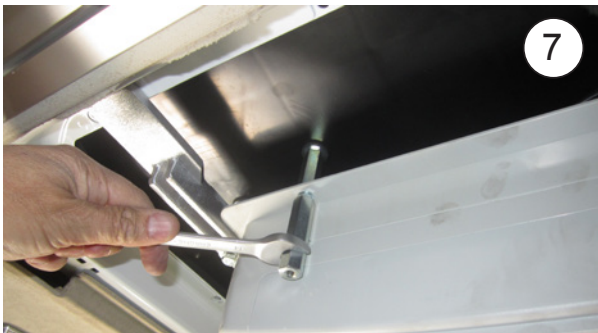
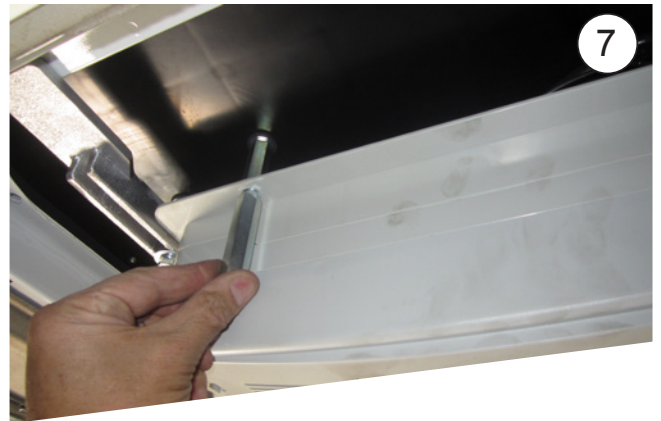

- 8** Roscar (4) hexágonos L=26 en los insertos de la base del equipo con arandela de goma, arandela plana y apretar con un par de apriete de $12,7 \pm 10\%$ Nm.



- 9** Colocar soportes de fijación con (4) tornillos 8/125x45 con arandela plana, arandela grower, **sin apretar.**



- 10** Presentar consola y centrar el equipo tomando como referencia el riel de la cortina (la consola debe hacer tope sobre el riel). Una vez centrado quitar consola.



- 11** Fijar los soportes de sujeción apretando los tornillos M8/125x45.



12 Colocar la consola con (4) tornillos M6/100x16.



Vista Explosionada hasta la fijación de los soportes

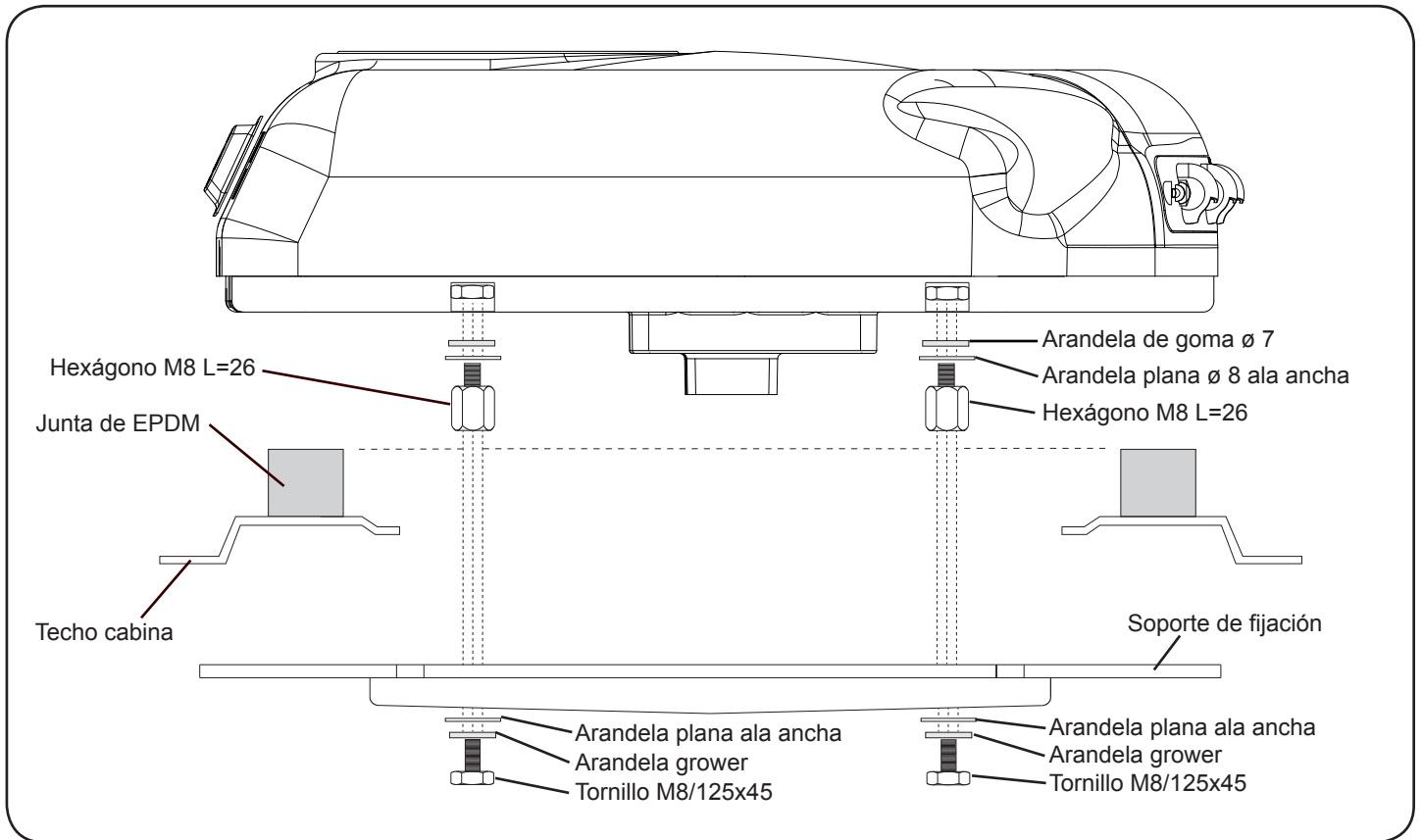

Vista explosionada hasta la fijación de las consolas

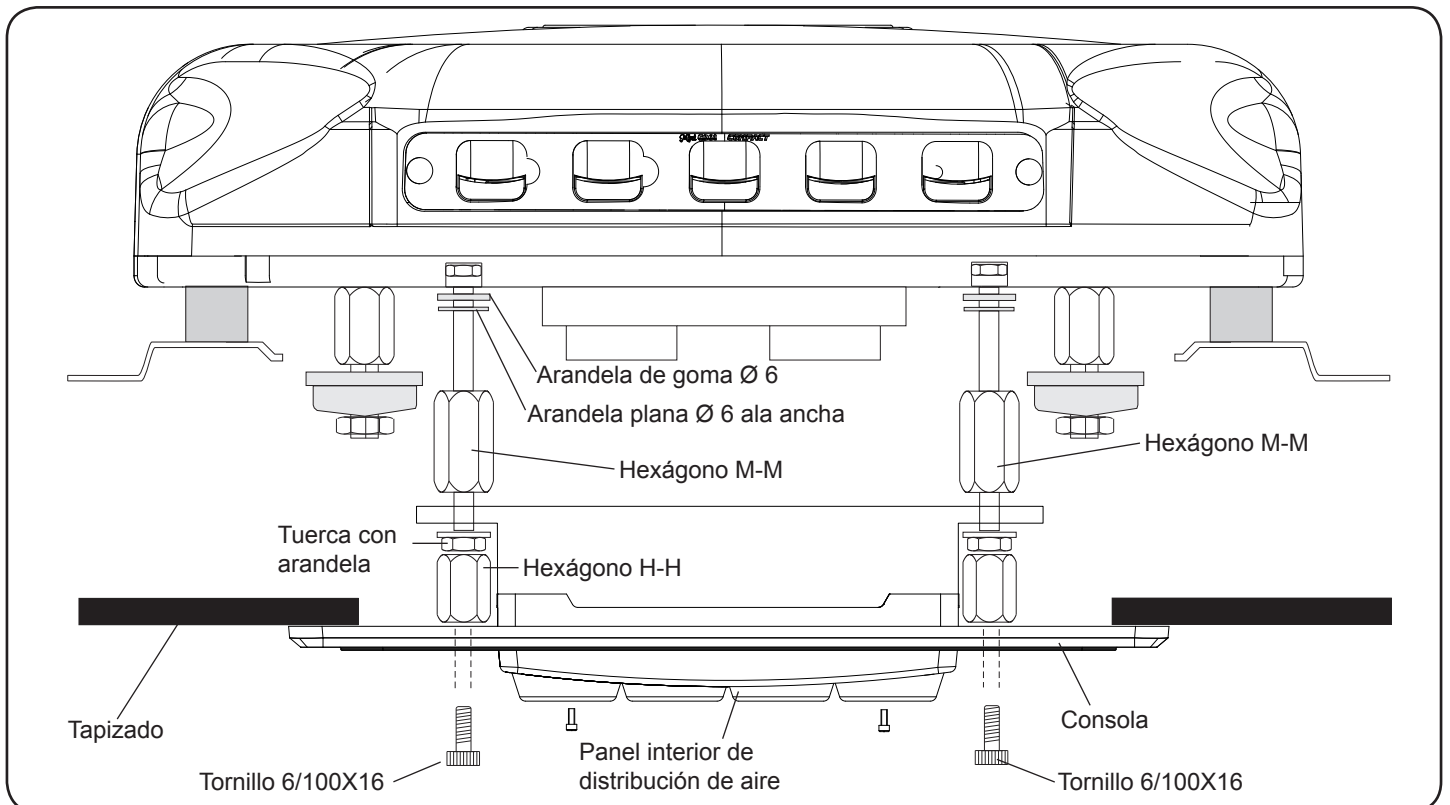

INSTRUCCIONES DETALLADAS SOBRE CONEXIÓN CABLEADO ALIMENTACIÓN

- 1** Conectar el cable de alimentación al equipo, fijarlo al techo con soportes con adhesivo y bridas. Después bajar el cableado por la parte trasera de la cabina.

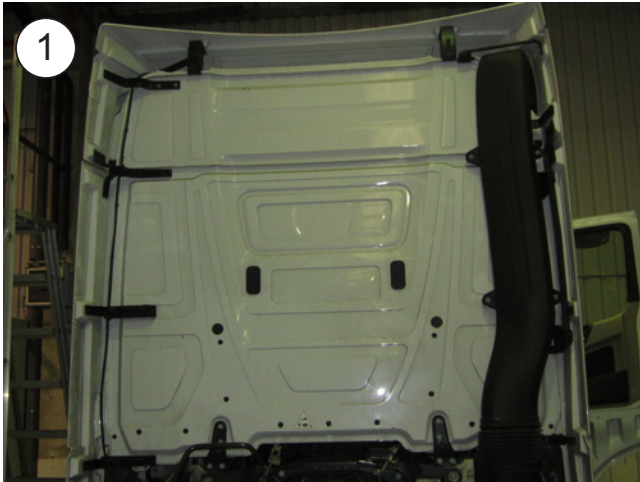

- 2** Conectar el otro extremo del cableado y llevar el cable positivo (azul) a caja de conexiones en posición X4.
Nota: Dependiendo de la ubicación de la caja de conexiones el cable positivo sobrarán en longitud. Cortar éste a longitud deseada.

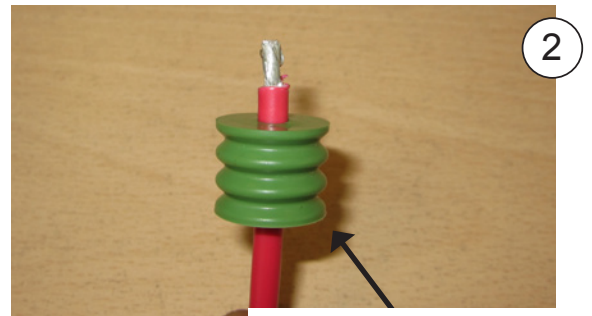

Introducir cableado por gomino suministrado

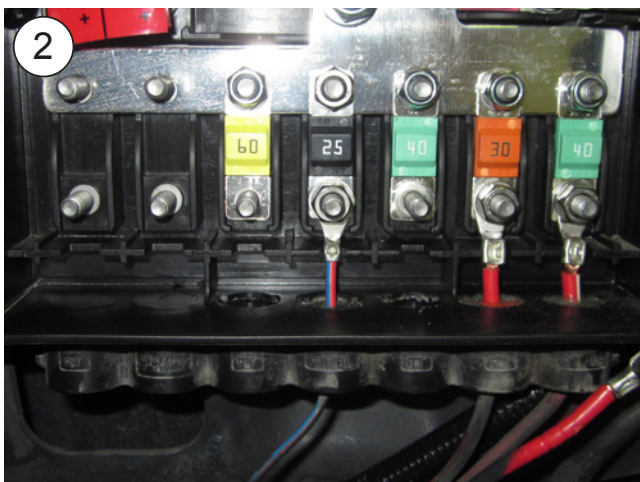

Pasar cableado por posición X4 y grapar terminal

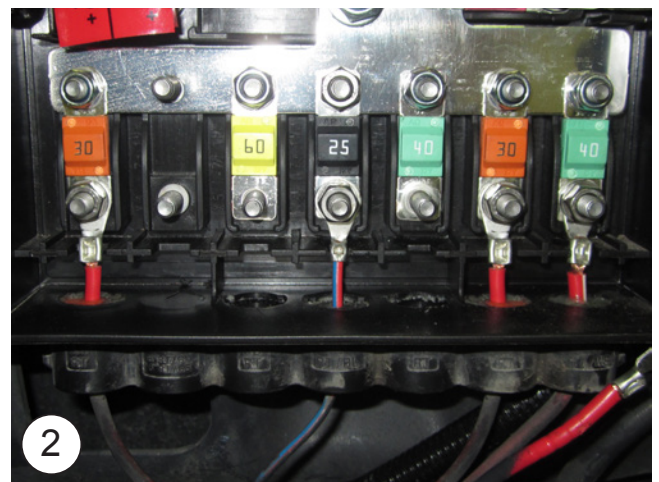

Colocar fusible suministrado 30A y fijar con arandela y tuerca

3 Llevar el cable marrón (negativo) a caja especial para ello.

Nota: Normalmente suele estar cerca de las baterías. Dependiendo de la ubicación de las baterías sobrar  cableado marr n, cortar a medida deseada y grapar terminal suministrado.

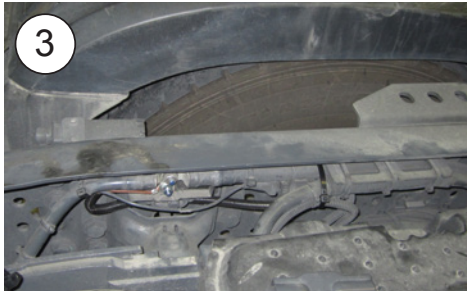

4 Colocar adhesivos seguridad cableado, en un lugar visible para recordar que hay que desconectarlo cada vez que se quiera abatir la cabina.



Esquema eléctrico

¡AVISO IMPORTANTE!

Precaución de no invertir las polaridades al conectar el equipo a la batería. Si esto sucediera la placa de mandos no se enciende y el equipo no funciona.

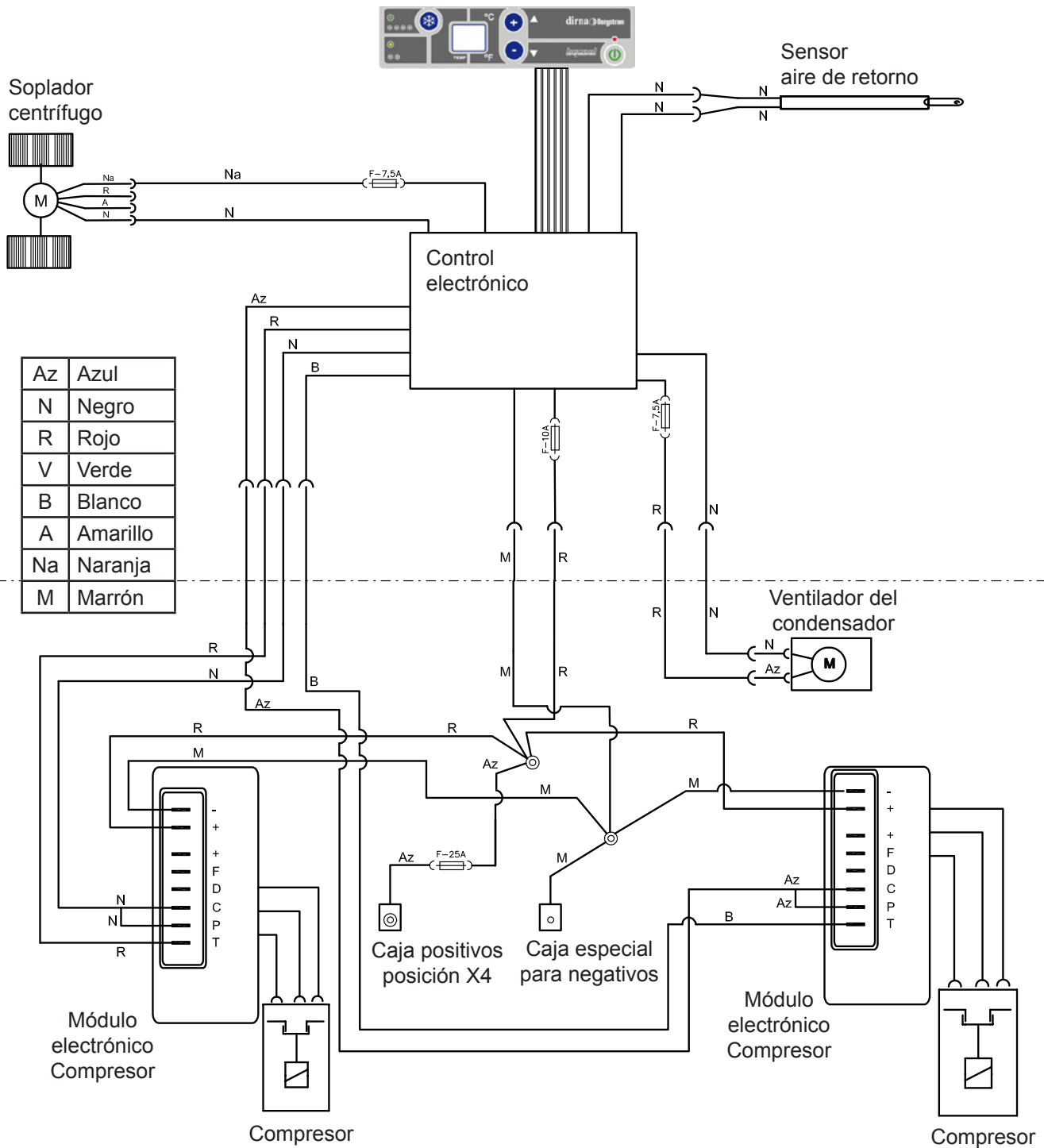

Assembly Recommendations

- Before starting assembly, please read instructions and follow them during installation process.
- Use the adequate tools for each operation.

Electricity

- Disconnect ignition key.
- Disconnect battery before starting assembly.
- Make sure electric components are securely connected, checking their correct fitting.

Warning

If the unit slants during assembly, wait for at least 60 minutes with the unit in horizontal position before starting it up.

Warning

When installing air conditioning equipment on roof, the upper cabin part must be protected with a cloth or a protective blanket to avoid possible scratches. When installing **Compact** on roof, take into account that, normally, cabins equipped with a hatch have a strong enough structure to hold equipment weight. However, if it is not the case and it is necessary to carry out a cut in the roof or, although it has a hatch, the material is not resistant enough (*if roof is made of fibre, plastic, etc...*), it is the installer who will have to decide, under his responsibility, if it is necessary to reinforce the roof to avoid possible deformations, breaks, water entries, etc., habilitating the means required to stop it from occurring.

Tools

Torx wrenches set

Allen wrenches set

Open-jawed spanner 10, 13, 14

Scissors

Flexo-meter

Related documentation

Mounting instructions	1001207475
User's guide	220AA60170
Troubleshooting	220AA60013
Warranty	220AA10017

Symbology



Fragile









Beware of cuts!



Electrical hazard

Warnings

-  The installing personnel must have a sufficient training in vehicles air conditioning.
-  **dirna Bergstrom s.l.** shall not be responsible for breakdowns or damages coming from an inadequate handling or installation of the equipment or from modifications and substitutions carried out without our express and written authorisation.
-  **Equipment pre-charged with refrigerating gas. (Do not handle refrigerating gas circuit).**
-  Please see product **warranty procedure** included in **Troubleshooting**.
-  Please see equipment **User's Guide** for its correct functioning of the remote control and control panel.
-  Once installation is finished, the following documents must be handed over to the user: **User's Guide**, **Warranty** and **Troubleshooting**.

 Mount the front air input grille before starting assembly.



1 Take down the hatch and the fastening elements, and hand them over to the customer.

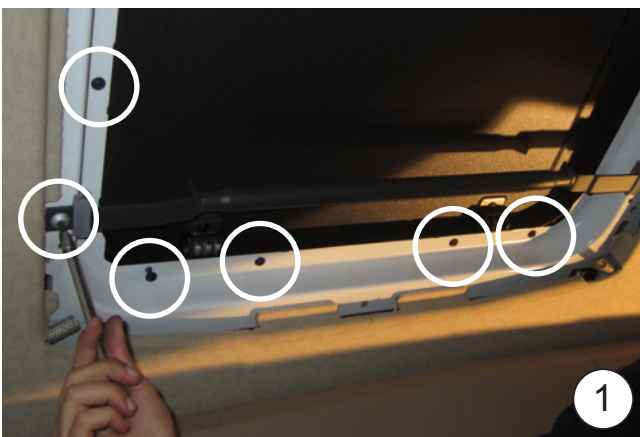
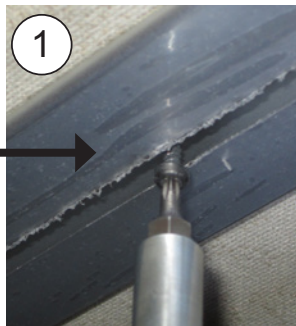
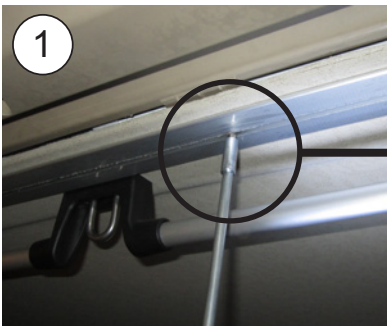
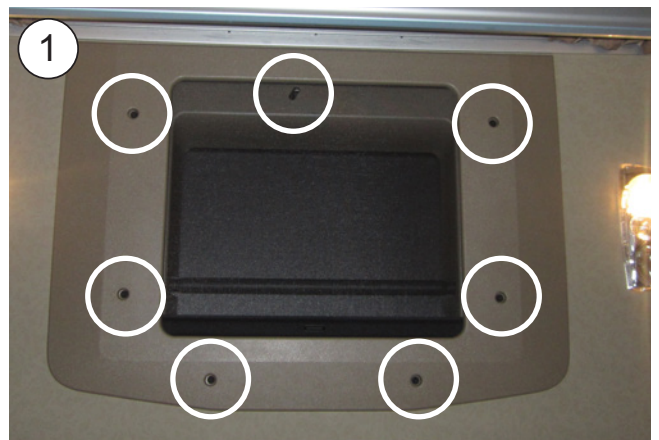
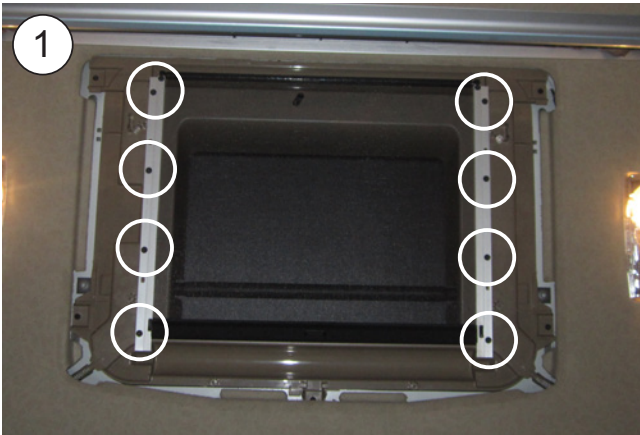

2 If the vehicle is fitted with a spoiler with the central bar, cut the bar shown along the dotted line to install the unit.

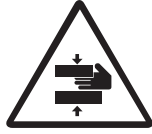

2a Attach the EPDM seal around the hatch gap (see the details to cut the ends of the seal joint).

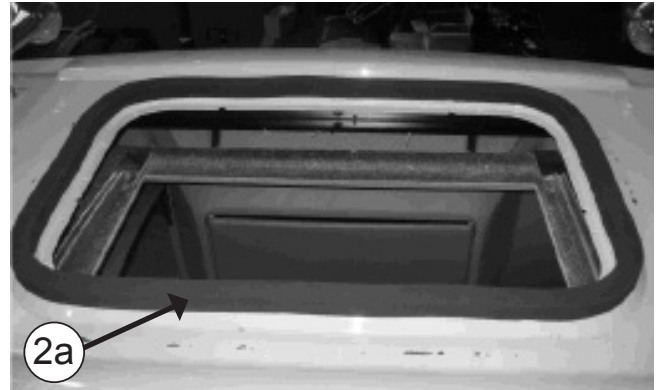

HOW TO CUT EPDM GASKET TO AVOID WATER FILTRATION INTO THE CABIN

- A-** Glue gasket, keeping 100 mm of protection paper at each side.
- B-** Remove the two pieces of paper.
- C-** Glue by pressing both ends.

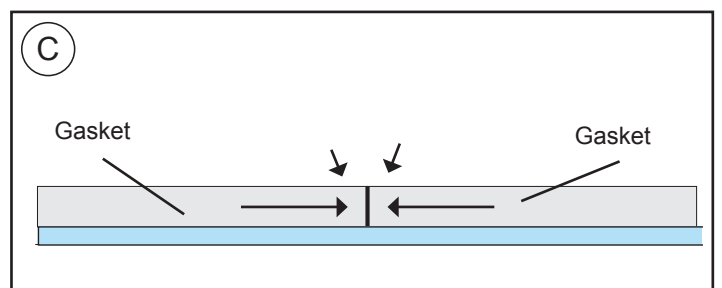
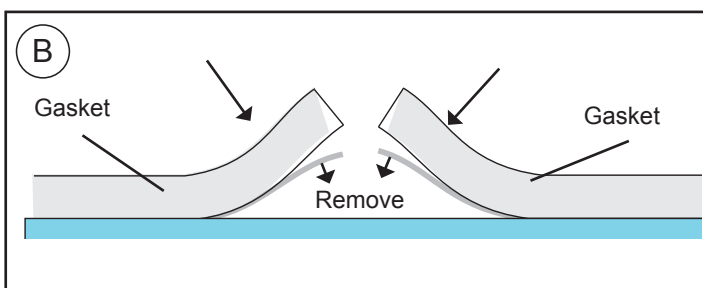
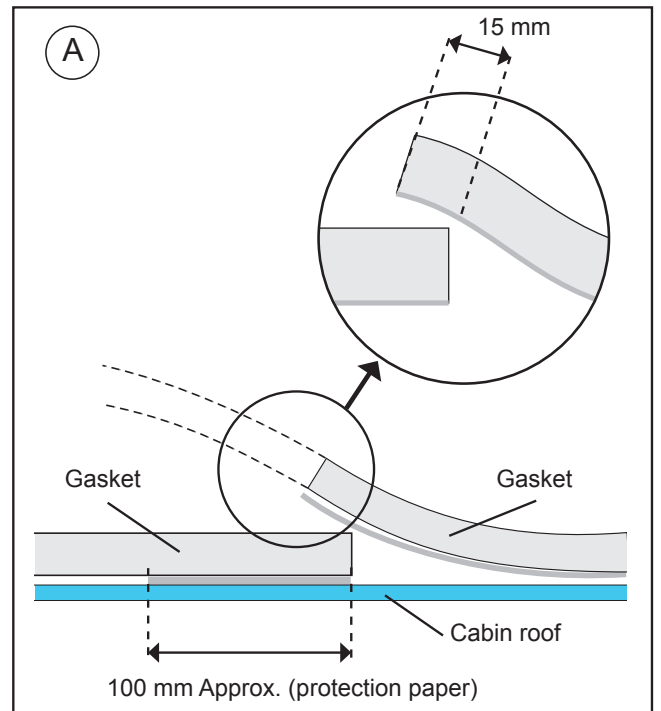

3 CABIN EXTERIOR:

Position the Compact in the hatch gap.

Caution! When positioning the unit above the hatch gap, check that the wastewater run-offs are not blocked by the EPDM seal.

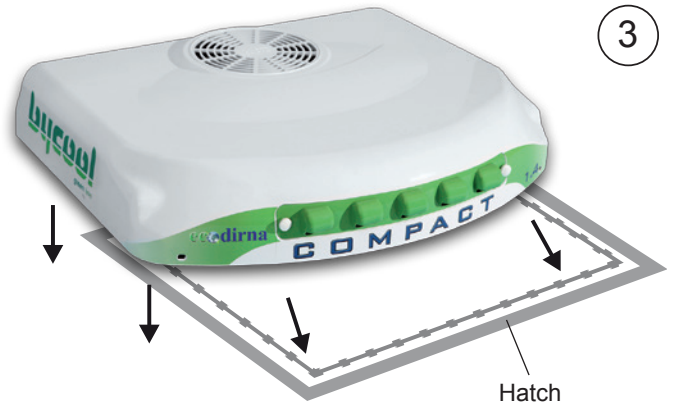

4 Position the foam rubber, ensuring the softest part is placed on the base of the unit.

Caution: Depending on the cabin, it may be necessary to use the (2) supplied ducts in order for the distribution panel to be completely adjusted.



5 Position (4) Ø6 rubber washers, (4) Ø6 wide-rimmed flat washers on L=43 hexagons. Then tighten the hexagons until the rubber washer is slightly oppressed.

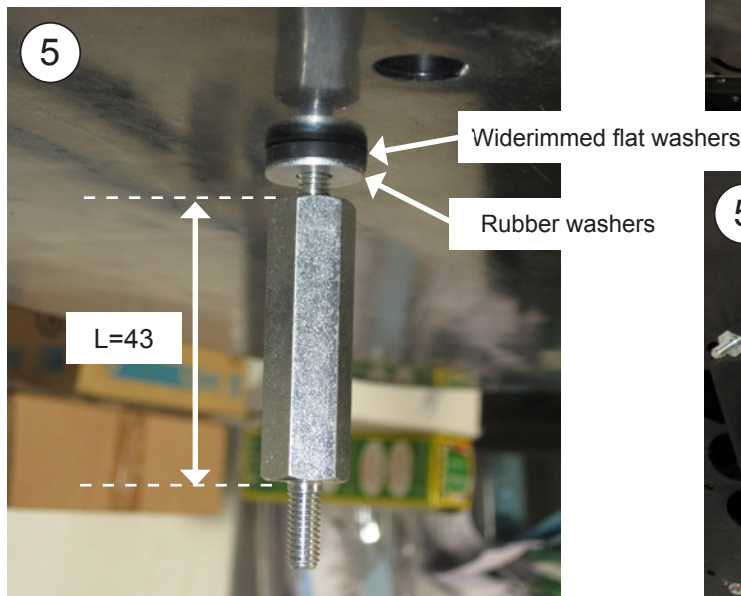
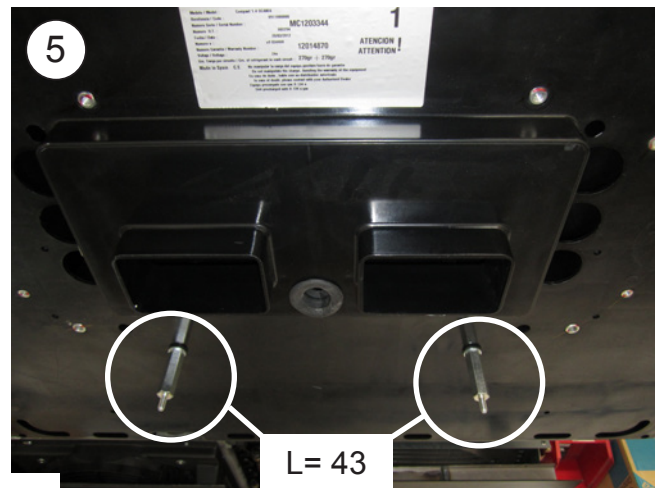

6 Connect the return air sensor 2-way box, the blower 4-way box and the electronic control cable connection 8-way box.

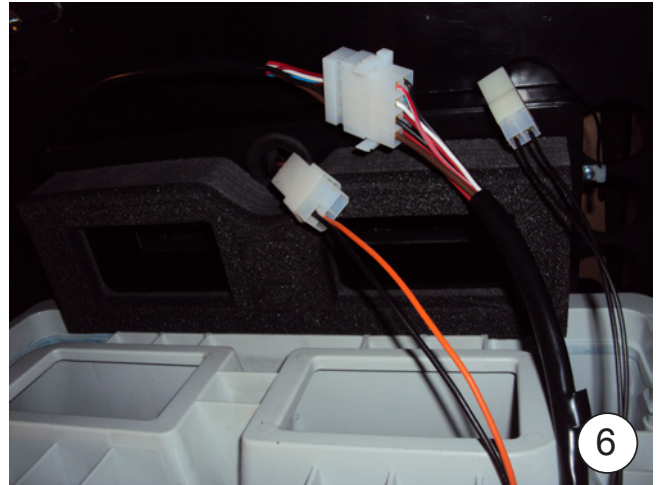

7 Position the interior air distribution panel on the front M-M hexagons and secure with (4) M6 nuts with a washer and (4) F-F L=64 hexagons.

Position the interior air distribution panel on the front M-M hexagons and secure with (4) M6 nuts with a washer and (4) F-F L=64 hexagons.

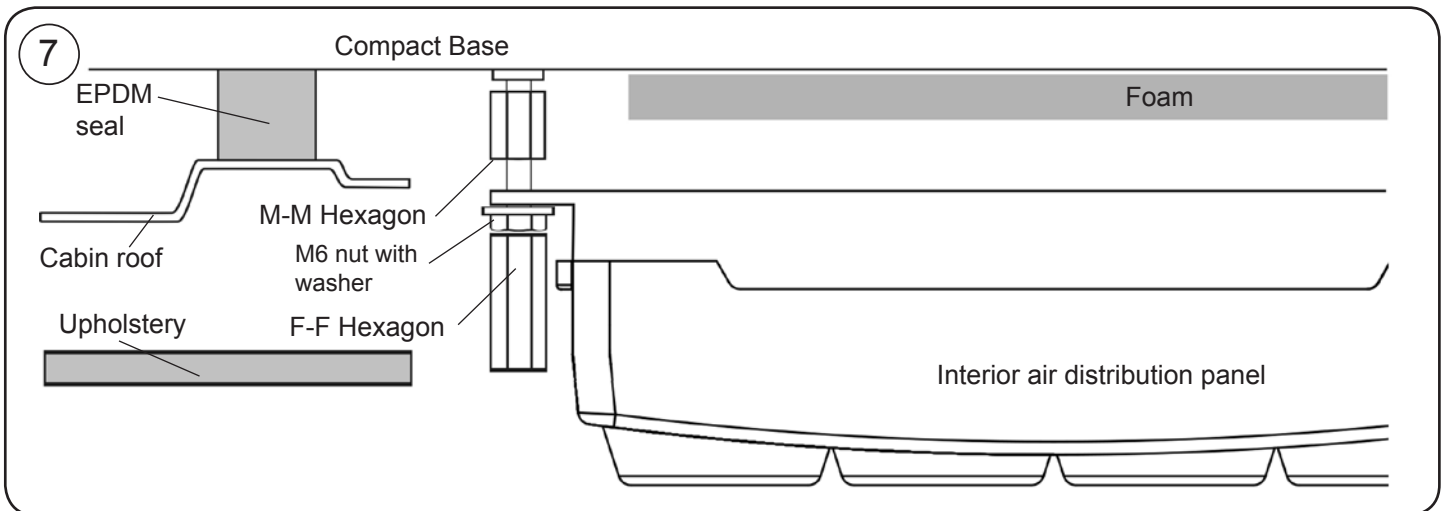
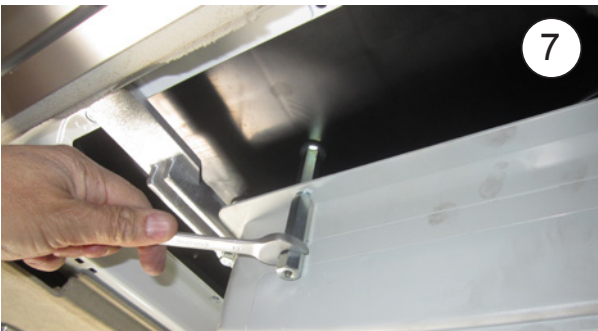
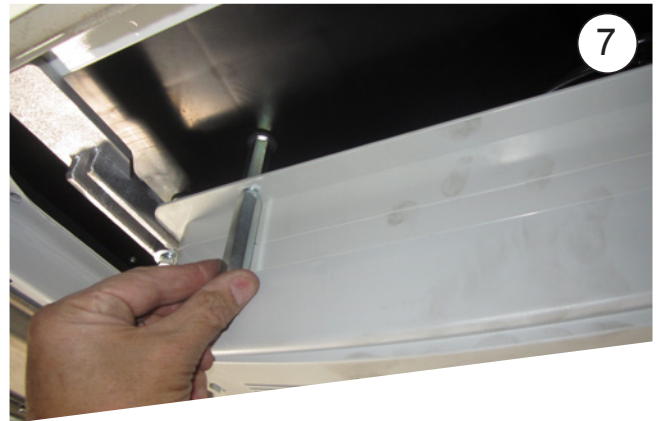

8 Screw (4) L=26 hexagons in the inserts in the base of the unit with a rubber washer and a flat washer, and tighten with a torque of $12.7 \pm 10\%$ Nm.



9 Position fastening brackets with (4) 8/125x45 screws with flat washer and grower washer, **without tightening**.



10 Position the console and align the unit using the curtain rail as a reference (the console must come up against the rail). Once aligned, remove the console.



11 Secure the fastening brackets by tightening the M8/125x45 screws.



12 Position the console with (4) M6/100x16 screws.



Exploded view through to mount fastenings

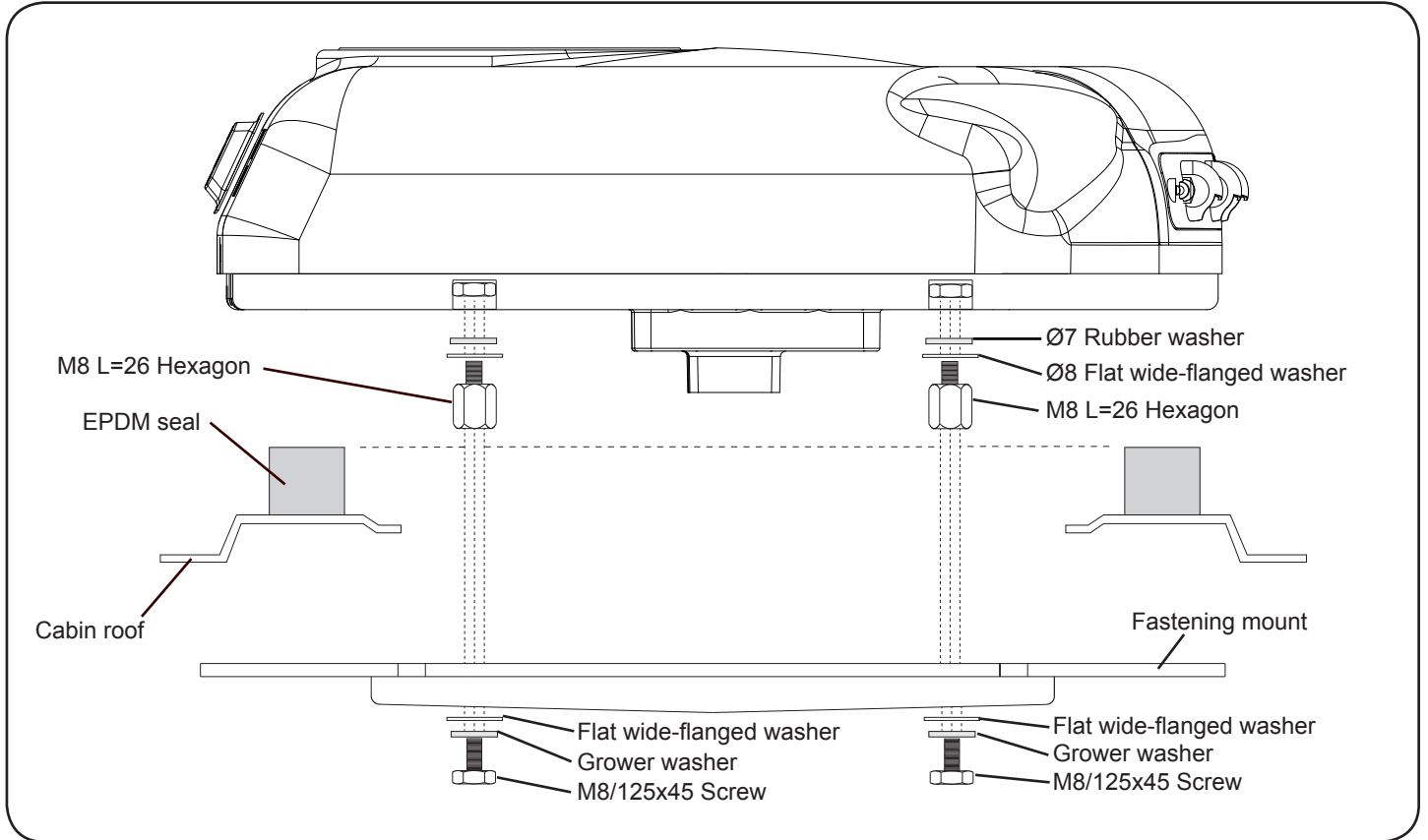

Exploded view through to the console fastenings

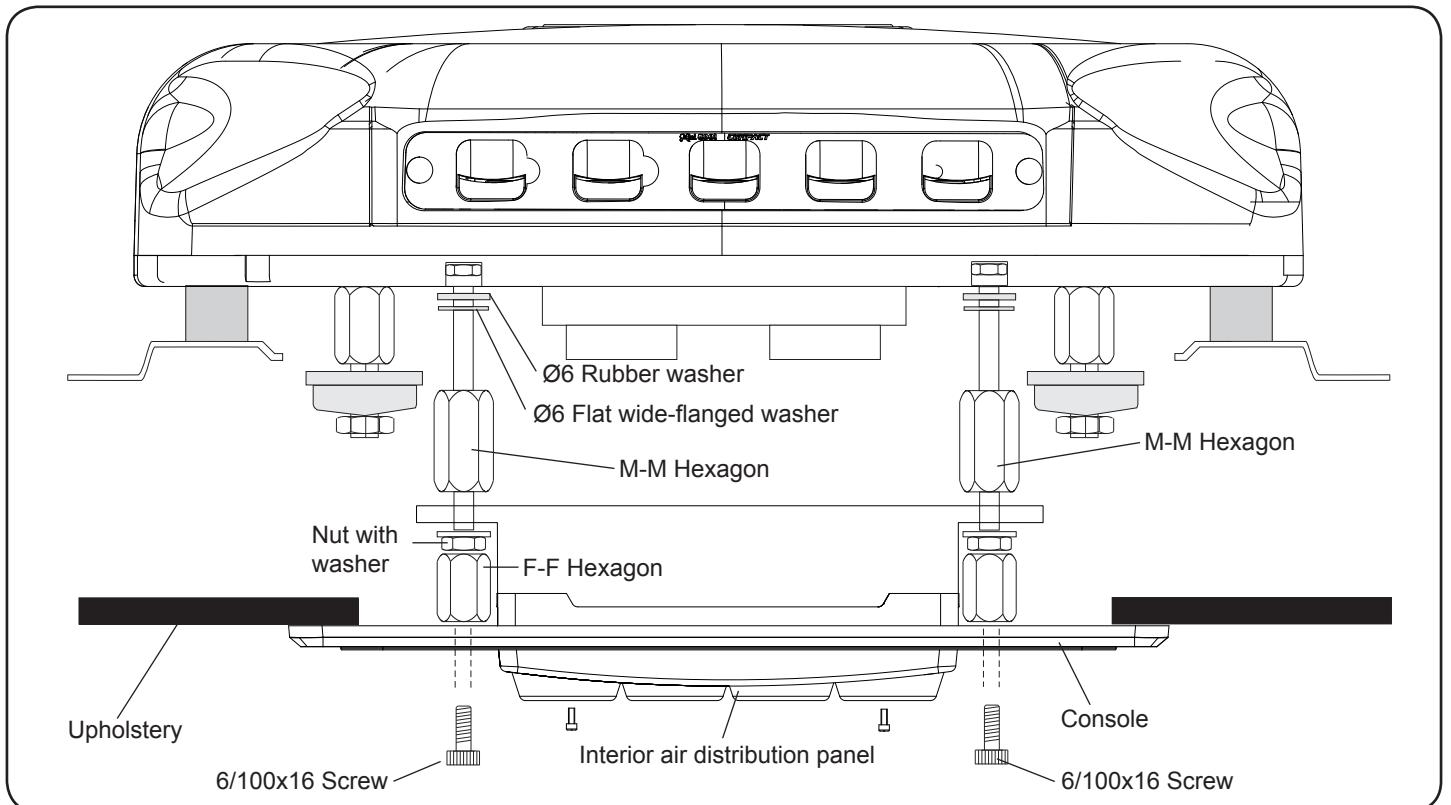

DETAILED INSTRUCTIONS ON
POWER CABLE CONNECTION

1 Connect the power cable to the unit, secure to the roof with the mounts and adhesive and flanges. Then lower the cable through the rear of the cabin.

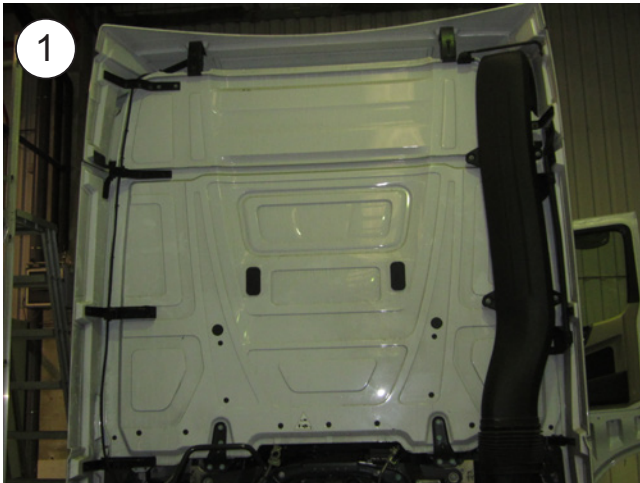

2 Connect the other end of the cable and connect the positive wire (blue) to the connections box in position X4.
Note: Depending on the location of the connections box, the positive wire will have excess length. Cut this to the required length.



Run the wire through the supplied rubber sleeve

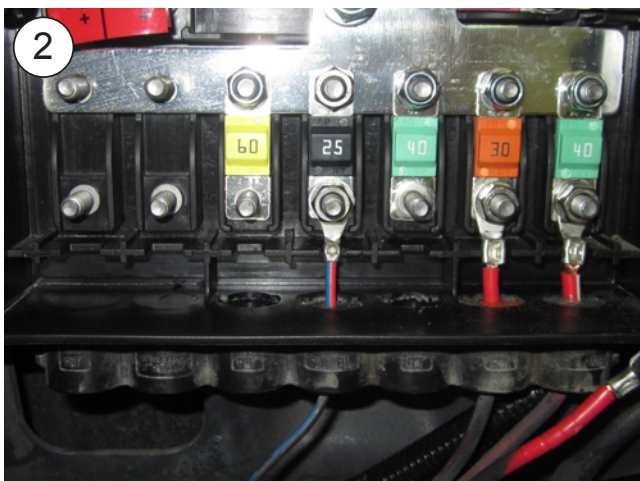

Pass the cabling through position X4 and clamp the terminal

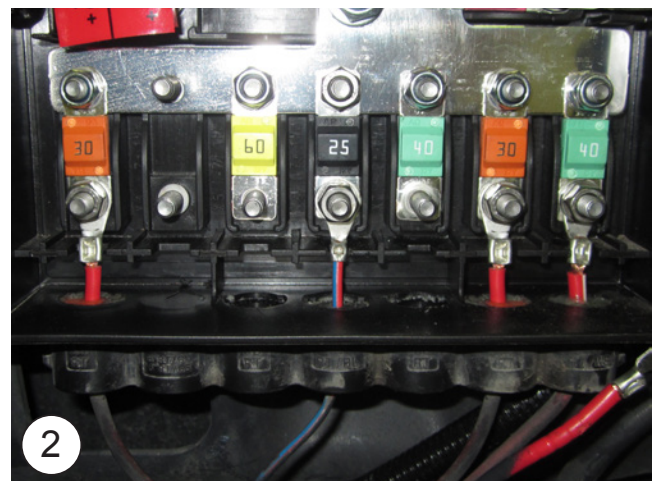

Position the supplied 30A fuse and secure with nut and washer

3 Run the brown wire (negative) to the specially fitted box.

Note: This is normally close to the batteries. Depending on the location of the batteries, the brown wire will have excess length; cut to the required size and clamp the supplied terminal.

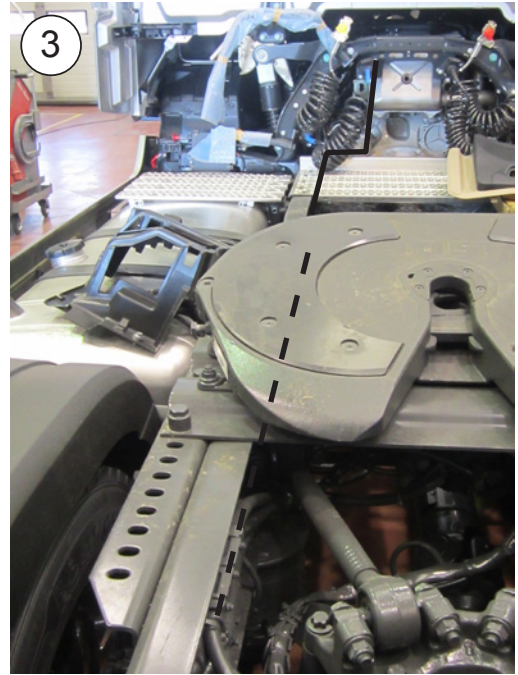

4 Position wire safety stickers in a visible place as a reminder to disconnect every time the cabin is tilted.



Wiring diagram

IMPORTANT NOTE!

Take care not to invert polarities when connecting the unit. If this happens, the plate does not come on and the unit does not work.

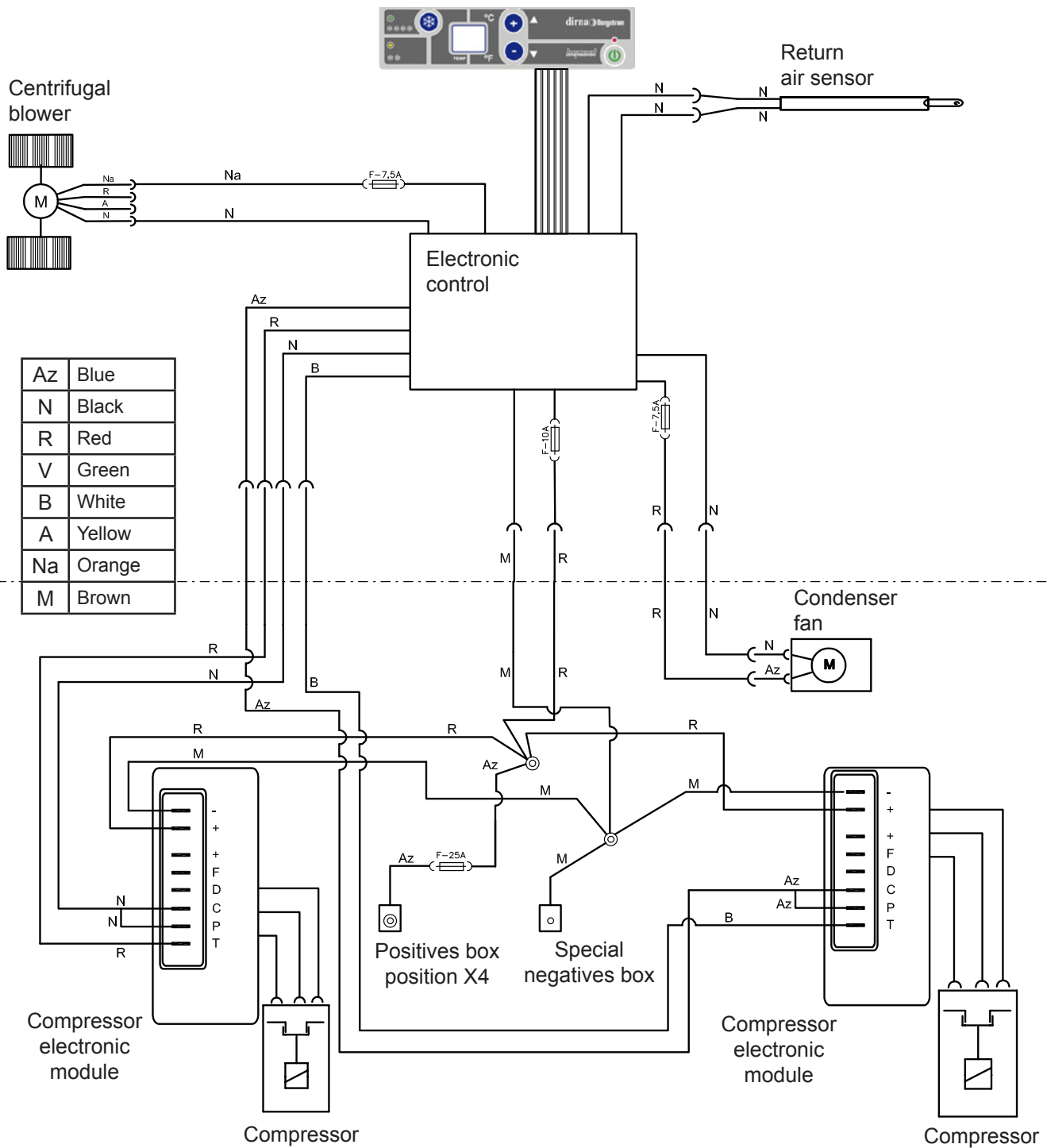

Recommandations Pour Le Montage

- Avant de commencer le montage de l'appareil, prière de lire les instructions et de les suivre attentivement.
- Utiliser les outils convenant à chaque opération.

Electricity

- Déconnecter la clé de contact.
- Déconnecter la batterie avant de commencer le montage.
- Vérifier le câblage des composants électriques et leur correcte installation.



Attention

Si pendant le montage l'équipement est incliné, il faudra attendre au moins 60 minutes avant de le mettre en marche une fois qu'il aura été remis sur sa position horizontale.



Attention

Lors de l'installation de l'appareil d'air conditionné sur le toit, il faudra protéger la partie supérieure de la cabine avec un linge ou une couverture de protection afin d'éviter les éventuelles égratignures.

Durant l'installation du **Compact**, tenir compte du fait que normalement les cabines pourvues d'écoutille possède une structure suffisamment solide pour supporter le poids de l'appareil. Cependant, si ce n'est pas le cas et qu'il est nécessaire de découper le toit ou même si disposant d'écoutille, la structure n'est pas suffisamment rigide (si elle était en fibre, plastique, etc.) il appartiendra à l'installateur de décider s'il faut renforcer le toit pour éviter toute déformation, rupture ou voie d'eau, etc., et prendre les mesures nécessaires à cet effet.

Outils

Jeu de clés Torx
 Jeu de clés Allen
 Clé fixe 10, 13, 14
 Ciseaux
 Mètre

Documentation associée

Instructions de montage	1001207475
Guide de l'utilisateur	220AA60170
Solution des problèmes	220AA60013
Garantie	220AA10017

Symbologie



Fragile



Attention aux coupures !



Risque électrique



Garantie



L'installateur devra posséder la formation pertinente en air conditionné sur véhicules.



dirna Bergstrom, s.l., ne sera pas responsable des dommages ou des bris dérivés d'une installation ou d'une manipulation incorrecte ni des modifications réalisées sans autorisation expresse par écrit.



Appareil pré-chargé de gaz réfrigérant. (Ne pas manipuler le circuit de gaz réfrigérant).



Voir la **procédure de garantie** du produit au **Diagnostic de problèmes**.



Voir le **Guide de l'Usager** de l'appareil pour le fonctionnement correcte de la télécommande et du tableau de commande.



Après l'installation, vous devez fournir à l'utilisateur: Manuel d'utilisation, garantie et diagnostic de pannes.

 Avant de commencer le montage, il faut monter la grille d'entrée d'air de la partie frontale.



1 Démontez l'écouille et les éléments de fixation et les remettre ensuite au client.

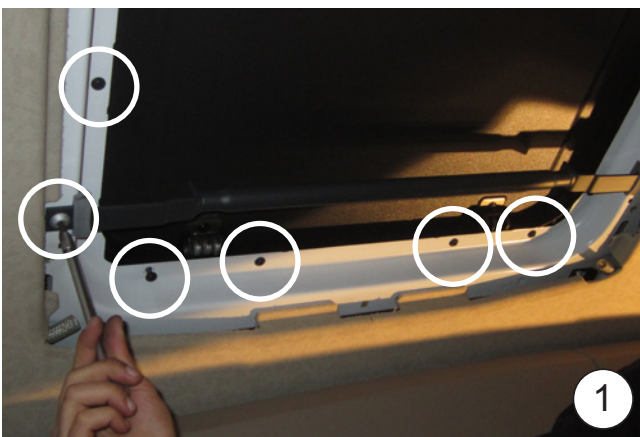
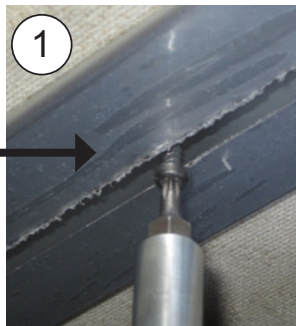
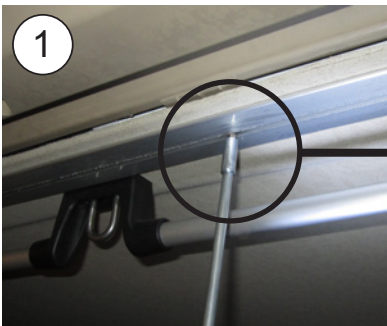
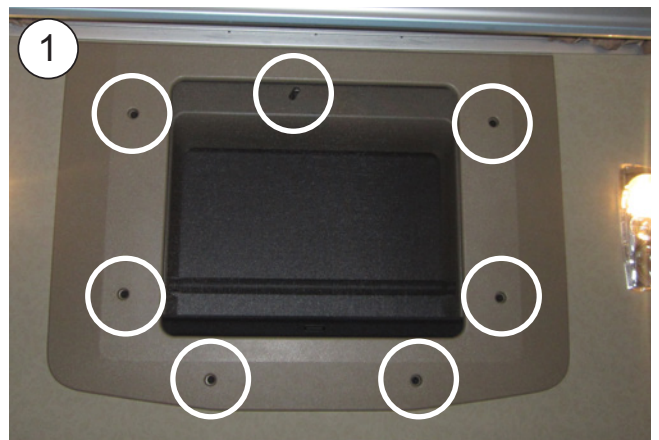

2 Si le véhicule incorpore un spoiler avec la barre centrale, il faut couper la barre en suivant les lignes de points pour installer l'équipement.



2a Coller le joint EPDM autour du creux de l'écoutille (observer le détail pour couper les bords fins de l'union du joint).

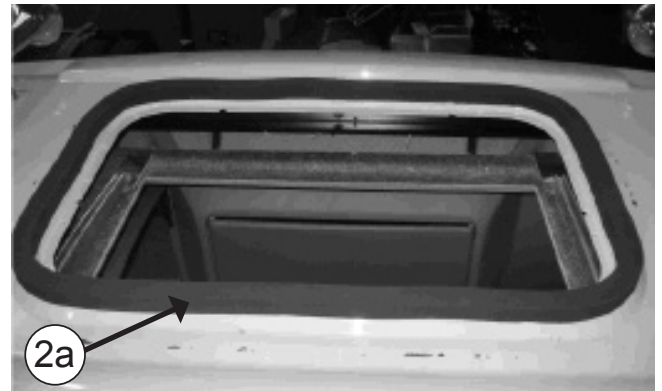

COMMENT COUPER LE JOINT EPDM POUR A EVITER LES FILTRATIONS DANS LA CABINE

- A- Coller le joint en maintenant une protection en papier de 100 mm de chaque côté.
- B- Retirer les deux morceaux de papier.
- C- Coller en faisant pression sur les deux extrémités.

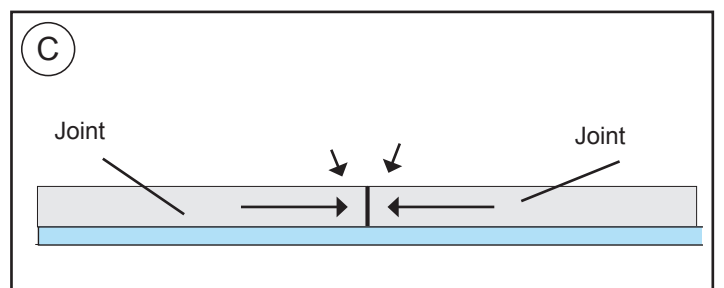
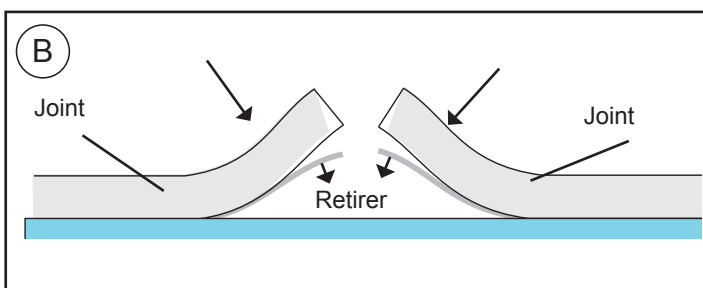
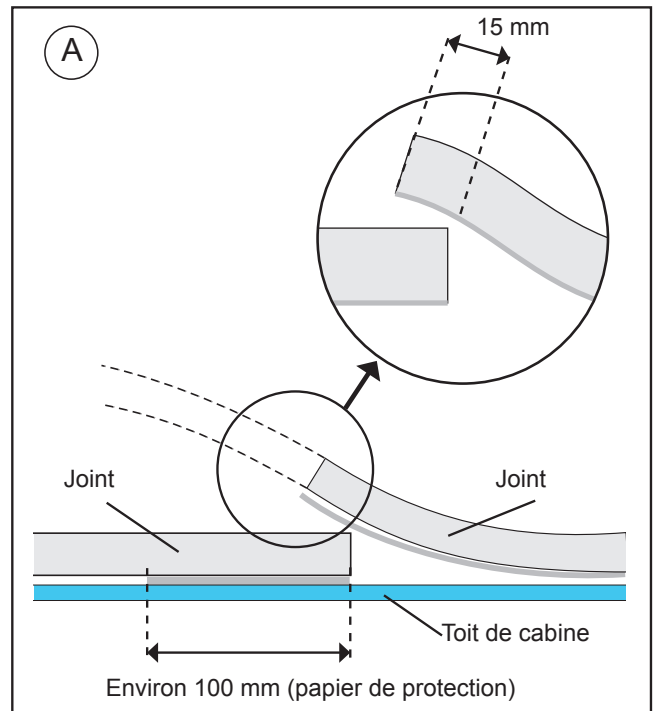

3 EXTÉRIEUR CABINE :

Placer le Compact dans le creux de l'écoutille.

Attention ! Avant de placer l'équipement dans le creux de l'écoutille, il faut réviser que les sorties d'écoulement ne soient pas bouchées par le joint EPDM.

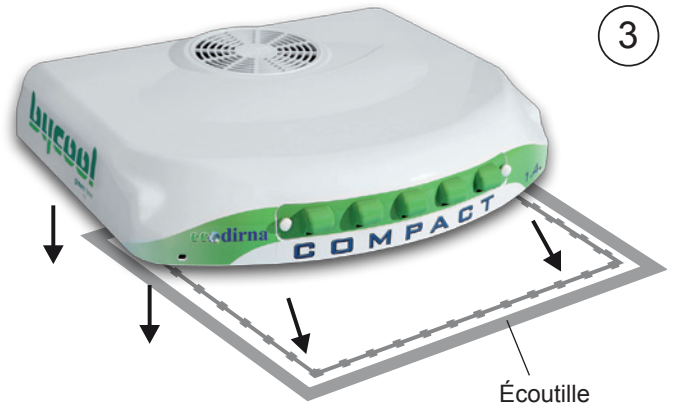

3

4 Placer le canalisateur en caoutchouc mousse en laissant la partie la plus molle sur la base de l'équipement.

Attention: en fonction de la cabine, il est possible de devoir utiliser les (2) canalisateurs fournis pour que le panneau de distribution d'air reste totalement ajusté avec ces derniers.

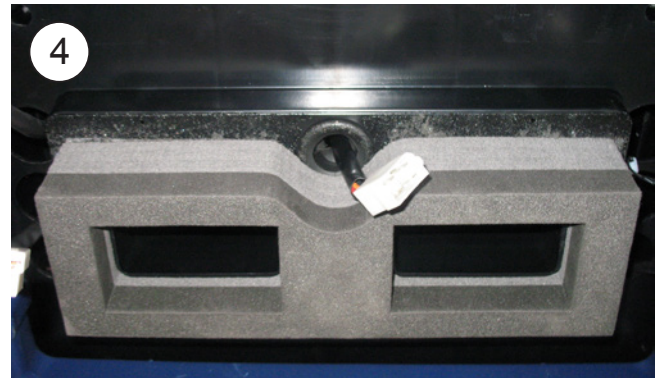

4

5 Placer (4) rondelles Ø 6 en caoutchouc, (4) rondelles plates Ø 6 à surface large sur les hexagones L=43. Serrer ensuite les hexagones jusqu'à ce que la rondelle en caoutchouc soit légèrement comprimée.

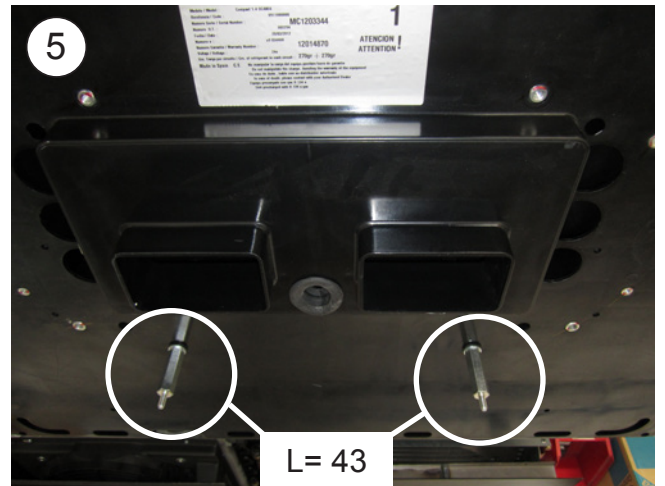

5

L=43

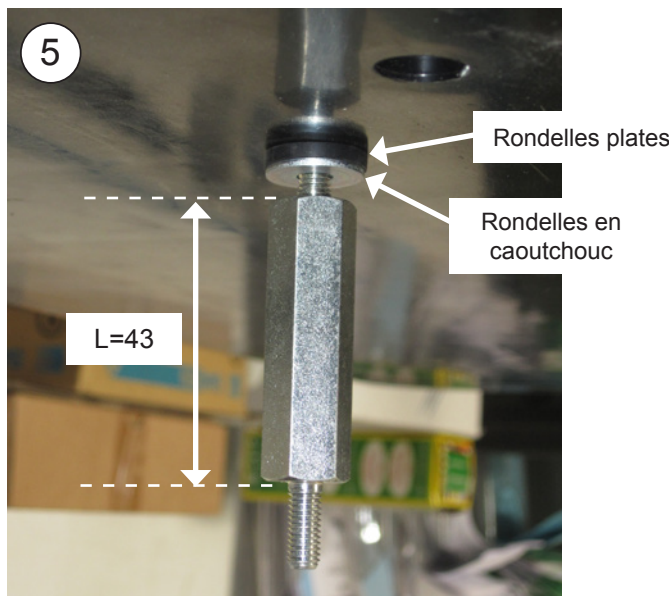

5

L=43

Rondelles plates

Rondelles en caoutchouc



5

6 Connecter le boîtier à 2 voies du capteur d'air de retour, le boîtier à 4 voies du souffleur et celui à 8 voies de connexion des câblages du contrôle électronique.

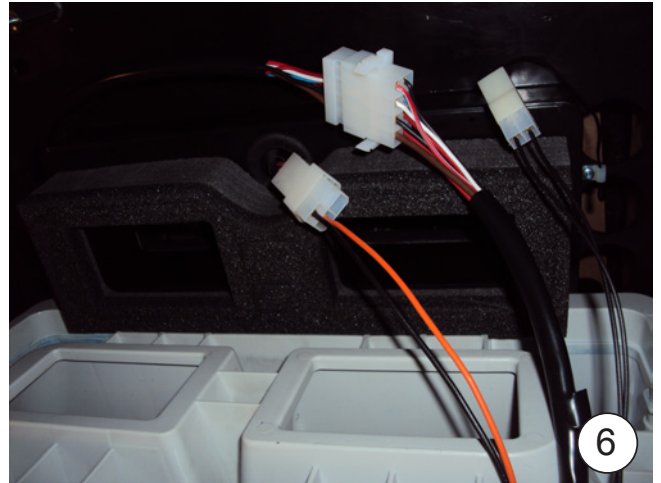

7 Placer le panneau intérieur de distribution d'air dans les hexagones M-M antérieurs et fixer avec (4) écrous M6 avec rondelle et (4) hexagones H-H L=64.

Important : les canalisateurs en caoutchouc mousse doivent heurter le caoutchouc mousse supérieur de l'équipement pour éviter des fuites d'air.

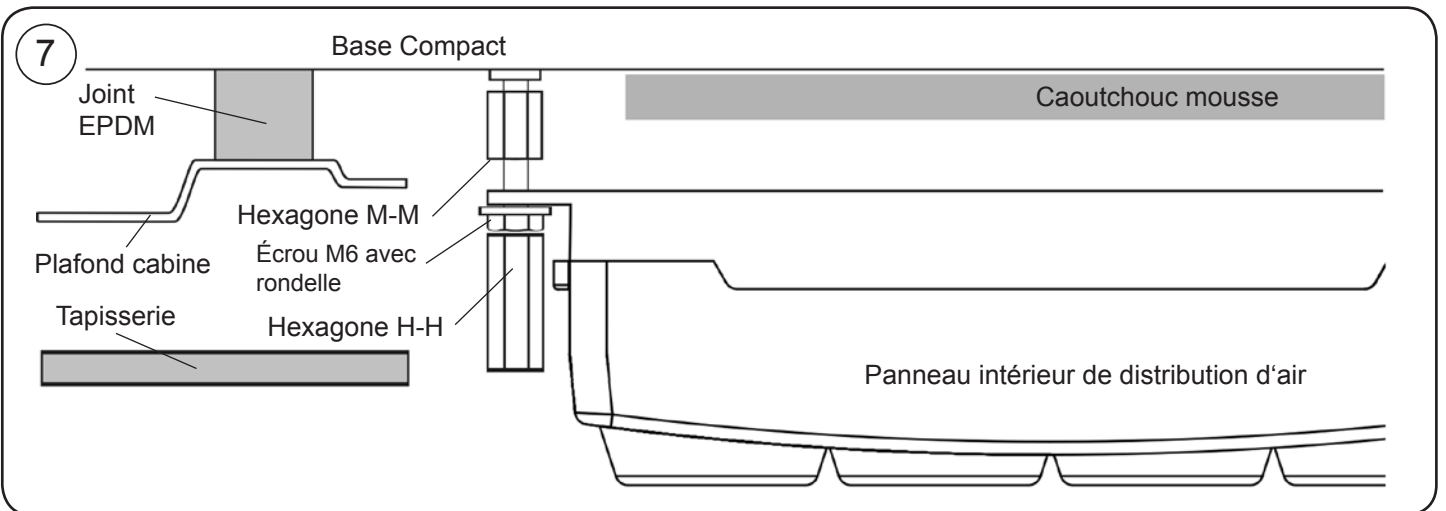
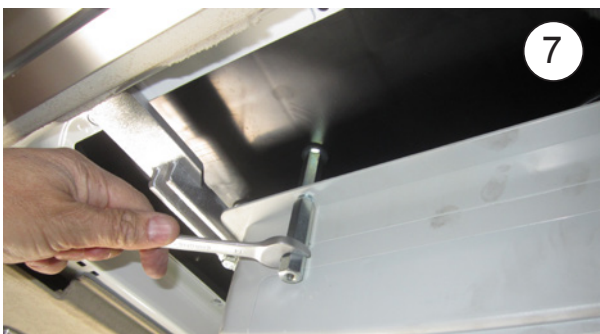
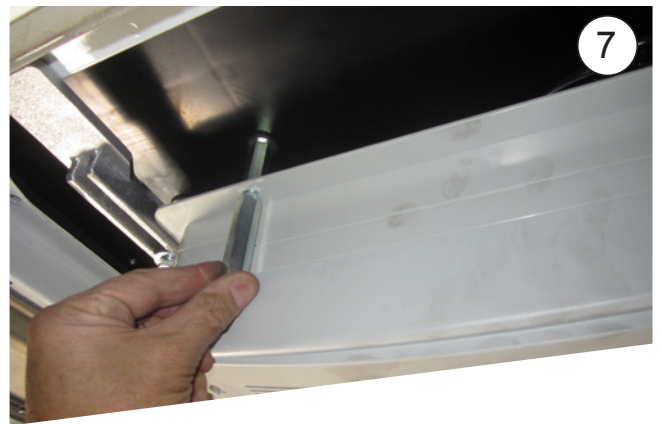

- 8** Visser (4) hexagones L=26 dans les inserts de la base de l'équipement avec une rondelle en caoutchouc, une rondelle plate et serrer avec un couple de serrage de $12,7 \pm 10\%$ Nm.



- 9** Placer les supports de fixation avec (4) vis 8/125x45 avec une rondelle plate, une rondelle grower, **sans serrer**.



- 10** Présenter la console et centrer l'équipement en prenant comme référence le rail du rideau (la console doit être en contact avec le rail). Une fois le centrage effectué, il faudra retirer la console.



- 11** Fixer les supports de fixation en serrant les vis M8/125x45.



12 Placer la console avec (4) vis M6/100x16.

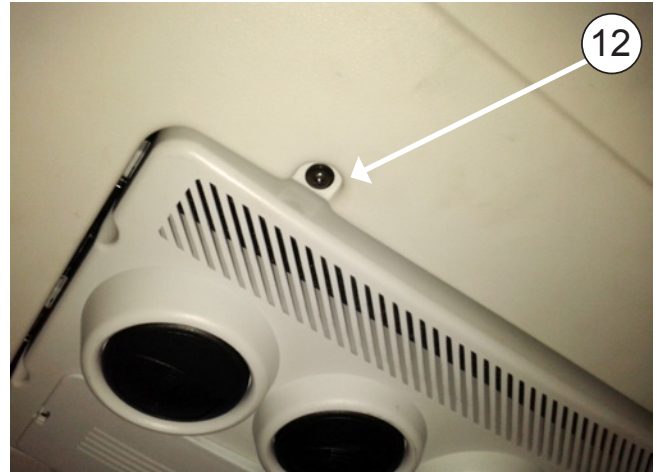

Vue éclatée jusqu'à la fixation des supports

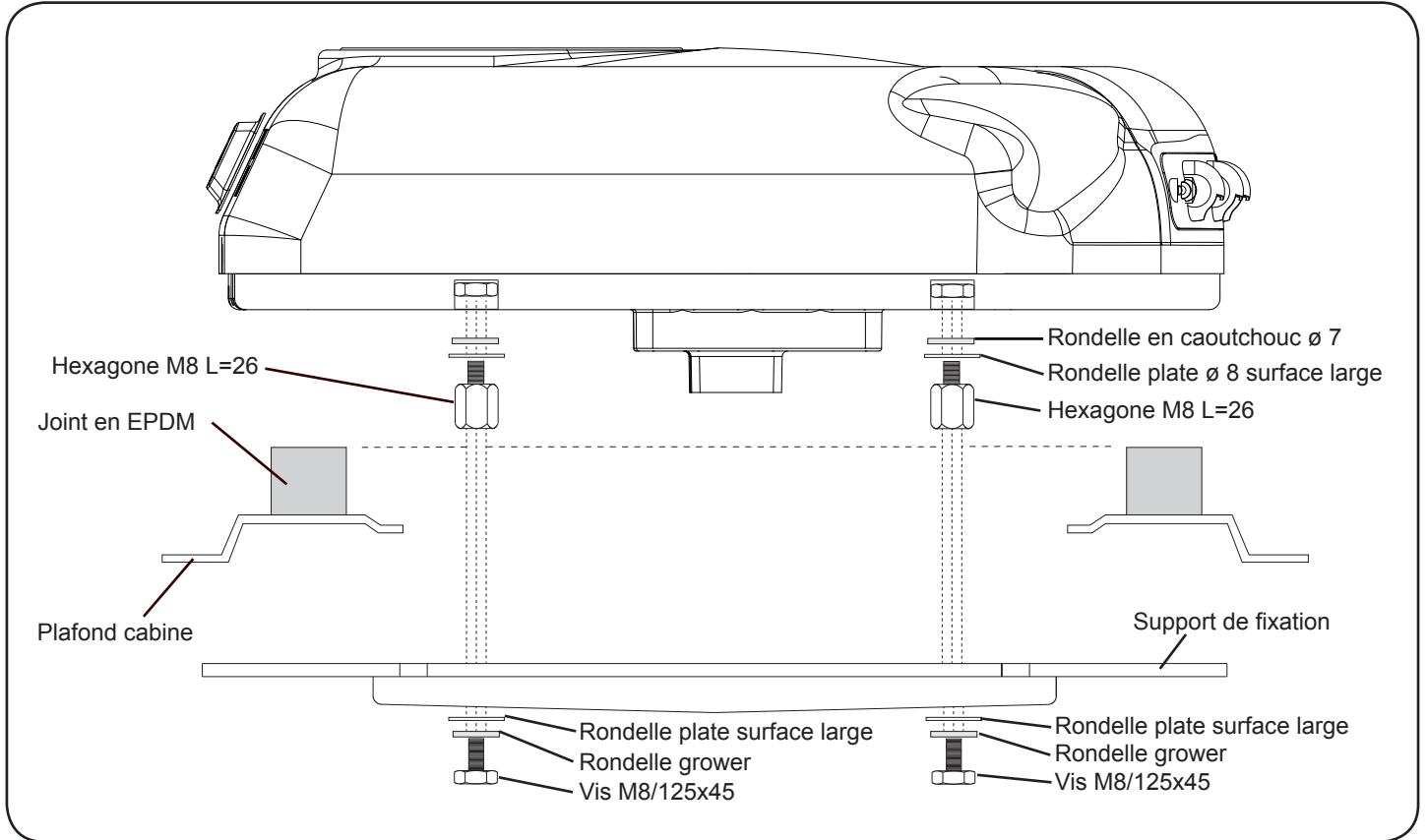

Vue éclatée jusqu'à la fixation des consoles

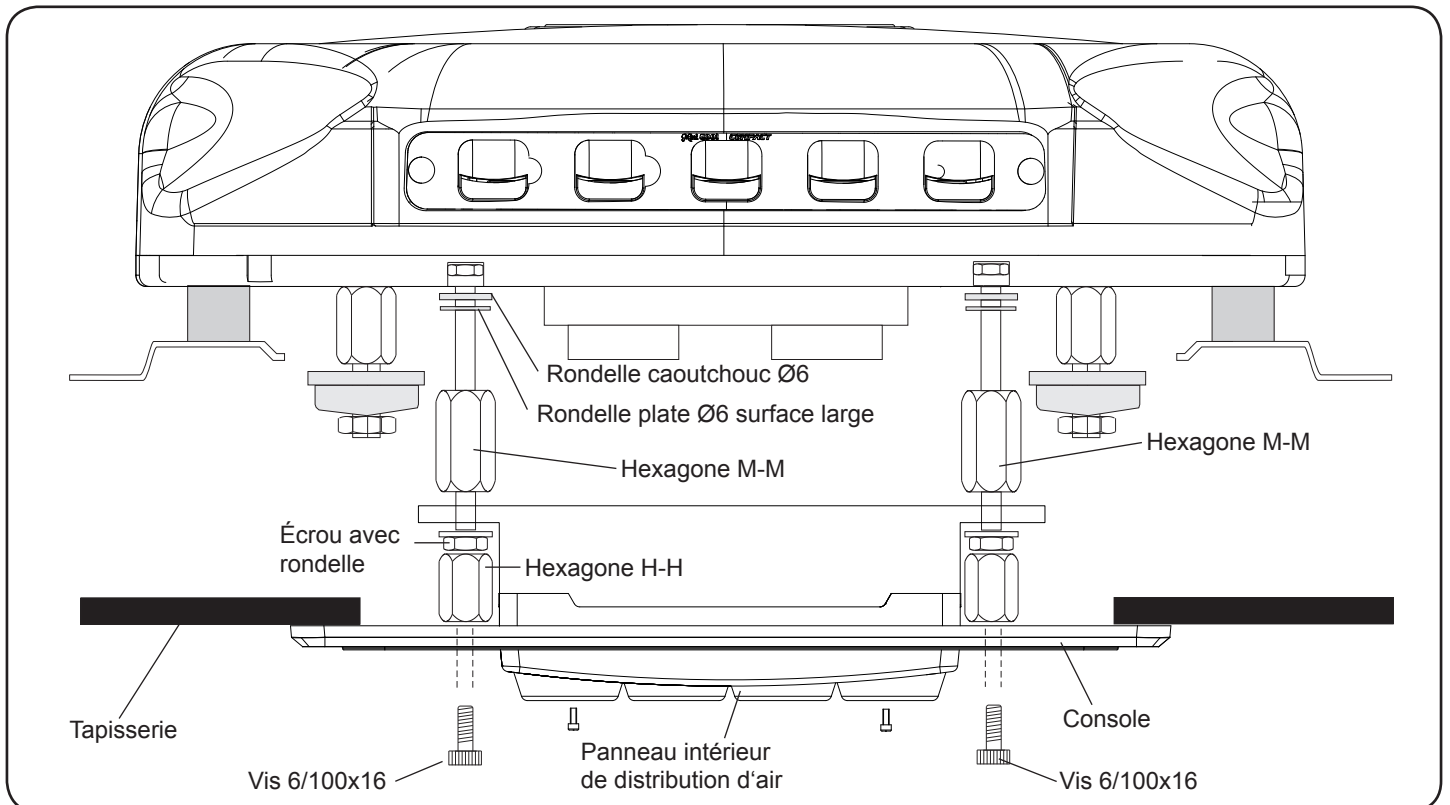

INSTRUCTIONS DÉTAILLÉES SUR LA CONNEXION DU CÂBLAGE D'ALIMENTATION

- 1** Connecter le câble d'alimentation à l'équipement, le fixer au plafond avec des supports à l'aide d'adhésifs et de brides. Ensuite, descendre le câblage par la partie arrière de la cabine.

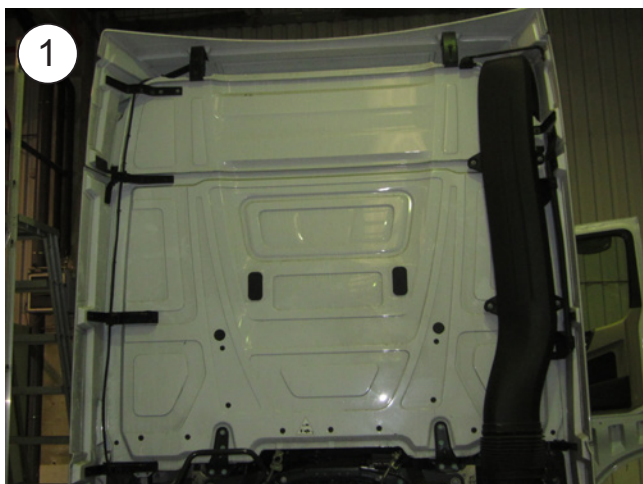

- 2** Connecter l'autre extrémité du câblage et porter le câble positif (bleu) à la boîte de jonction sur la position X4.

Remarque: en fonction de l'emplacement de la boîte de jonction, il est possible qu'il y ait du câble positif en trop. Dans ce cas, coupez-le à la longueur désirée.



Introduire le câblage à travers l'élément cannelé fourni

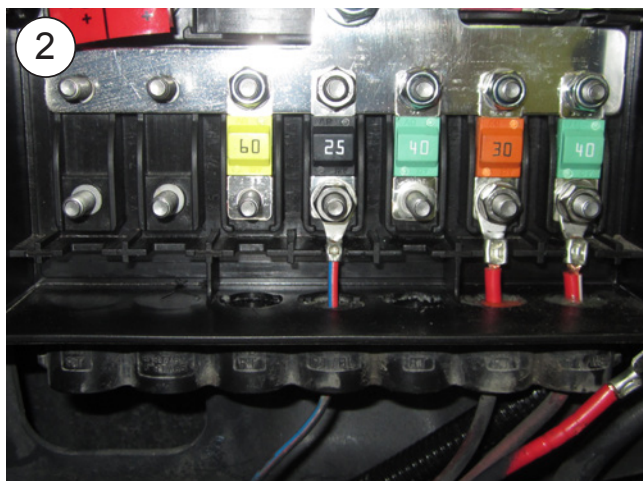

Passer le câblage par la position X4 et agraffer le terminal

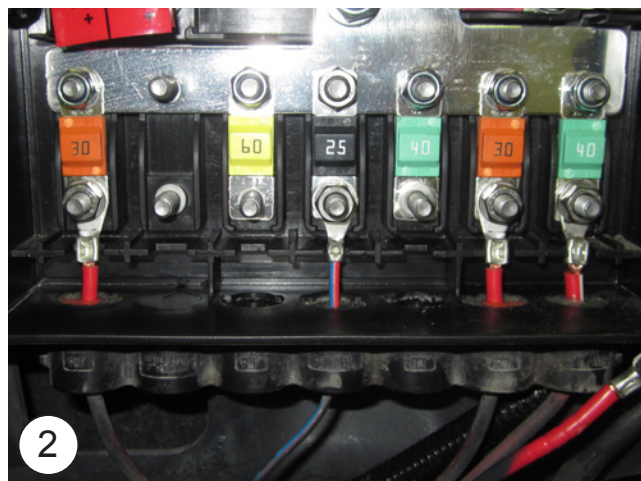

Placer le fusible fourni 30A et le fixer avec une rondelle et un écrou

3 Porter le câble marron (négatif) à la boîte spéciale conçue à cet effet.

Remarque : il se trouve normalement près des batteries. En fonction de l'emplacement des batteries, il est possible qu'il y ait du câble marron en trop. Dans ce cas, coupez-le à la longueur désirée et agrafez le terminal fourni.

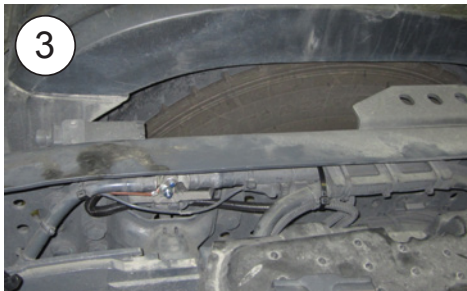

4 Placer les adhésifs de sécurité du câblage sur un lieu visible pour rappeler le besoin de le déconnecter avant d'abattre la cabine.



Schéma électrique

AVIS IMPORTANT !

Attention de ne pas inverser les polarités au moment de connecter l'équipement. Si cela se produisait, la plaque de commande ne s'allumerait pas et l'équipement ne fonctionnerait pas.

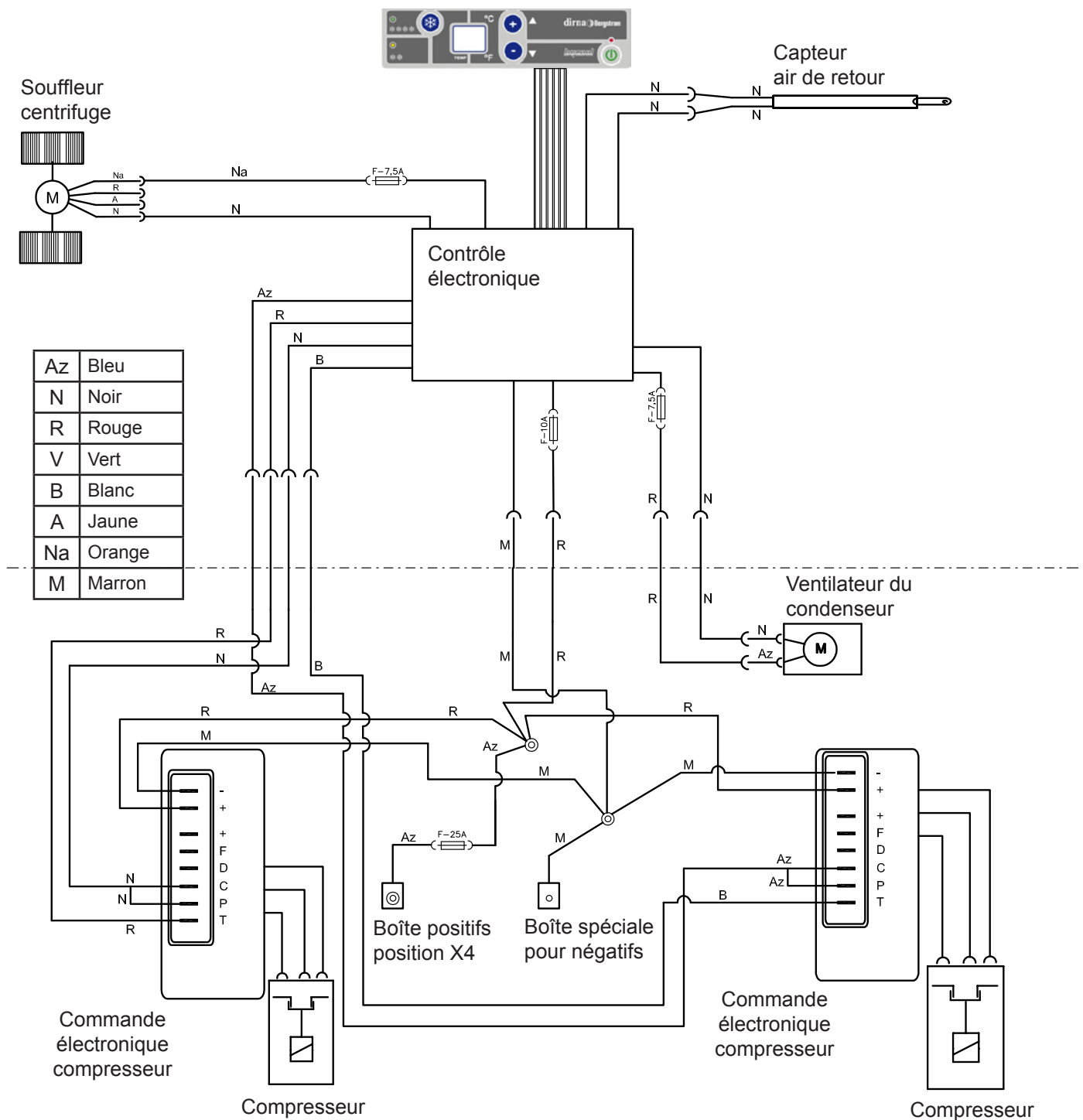

Empfehlungen Zur montage

- Vor und während der Montage bitte diese Anweisungen lesen und beachten.
- Benutzen Sie für jeden Arbeitsschritt die geeigneten Werkzeuge.

Elektrizität

- Zündschlüssel abziehen.
- Vor Montagebeginn die Batterie abklemmen.
- Den ordnungsgemäßen Anschluss und die korrekte Installation der Elektrokomponenten überprüfen.

Achtung

Sollte sich das Gerät während der Montage neigen, muss man mindestens 60 Minuten warten, nachdem es wieder in die horizontale Lage gebracht wurde, um es wieder einzuschalten.

Achtung

Wird die Klimaanlage im Kabinendach installiert, muss der obere Teil der Kabine mit einem Tuch oder einer Decke gegen eventuelle Kratzer geschützt werden. Bei der Installation der **Compact** auf dem Kabinendach muss darauf geachtet werden, dass mit Luken ausgestattete Kabinen über eine ausreichend stabile Struktur verfügen, um das Gewicht des Geräts stand zu halten. Sollte das Fahrzeug über keine Luke verfügen und sollte es notwendig sein, das Kabinendach aufzuschneiden, bzw. sollte die vorhandene Struktur nicht ausreichend stabil sein (z.B. wenn sie aus Faser, Kunststoff usw. hergestellt ist), obliegt es dem Installateur zu entscheiden, ob das Kabinendach zur Vermeidung von Verformungen, Brüchen, undichten Stellen usw. verstärkt werden muss, und die hierfür notwendigen Mittel bereit zu stellen.



Werkzeuge

- Torx-Schraubenschlüssel
- Inbusschraubenschlüssel
- 10er, 13er, 14er Schraubenschlüssel
- Schere
- Metermaß







Zugehörige Dokumentation

Montageanweisungen	1001207475
Benutzerleitfaden	220AA60170
Fehlerdiagnose	220AA60013
Garantie	220AA10017

Symbologie

-  Fragile
-  Attention aux coupures !
-  Risque électrique

Warnhinweise

-  Der Installateur muss im Bereich Fahrzeug-Klimaanlagen ausreichend geschult sein.
-  **dirna Bergstrom, s.l.** übernimmt keine Verantwortung für Schäden oder Brüche aufgrund einer nicht ordnungsgemäßen Installation oder Bedienung des Geräts oder den Austausch von Teilen bzw. Umbauten, die ohne die erforderliche schriftliche Genehmigung durchgeführt wurden.
-  **Mit Kältemittel vorgefülltes Gerät. (Kältemittelkreislauf nicht manipulieren).**
-  Siehe **Garantieverfahren** des Produkts in der **Fehlerdiagnose**.
-  Siehe **Benutzerleitfaden** des Geräts für den ordnungsgemäßen Betrieb der Fernbedienung und des Bedienfelds.
-  Die folgenden Unterlagen müssen dem Benutzer nach der Installation ausgehändigt werden: **Benutzerleitfaden, Garantie und Fehlerdiagnose.**

 Vor Montagebeginn vorderes Lufteintrittsgitter montieren.



1 Luke und deren Befestigungselemente ausbauen und diese dem Kunden aushändigen.

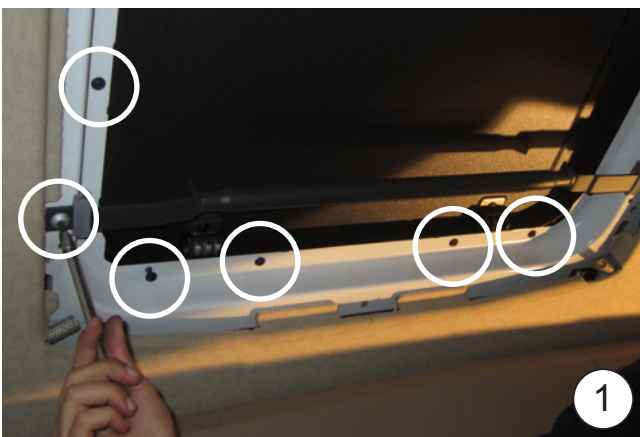
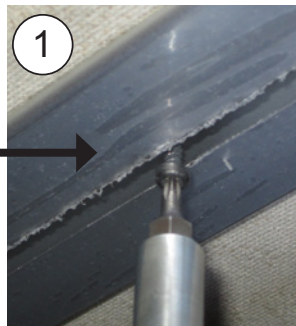
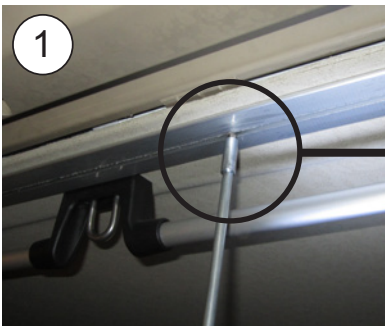
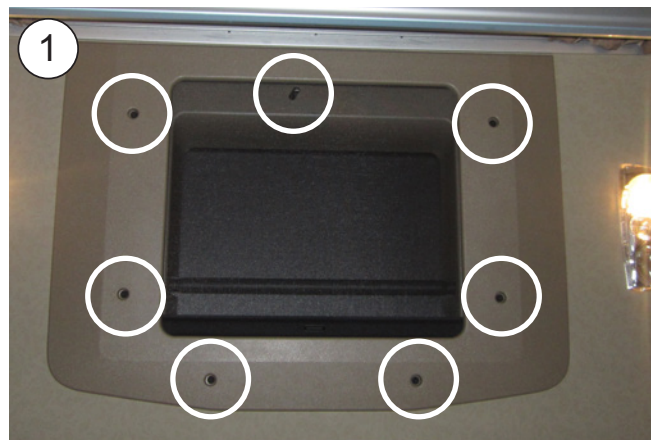
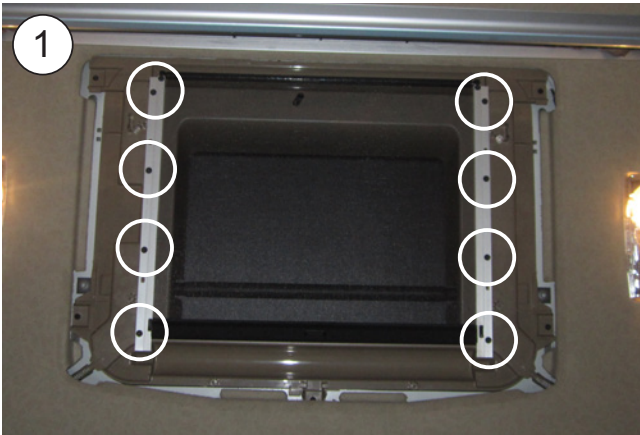

2 Hat das Fahrzeug einen Spoiler mit Mittelstange, diese für die Installation des Geräts an den angegebenen Punktlinien aufschneiden.



2a Die EPDM-Dichtung um die Lukenausparung herum kleben (siehe *Detailzeichnung für das Zurechtschneiden der äußeren Verbindungsränder*).

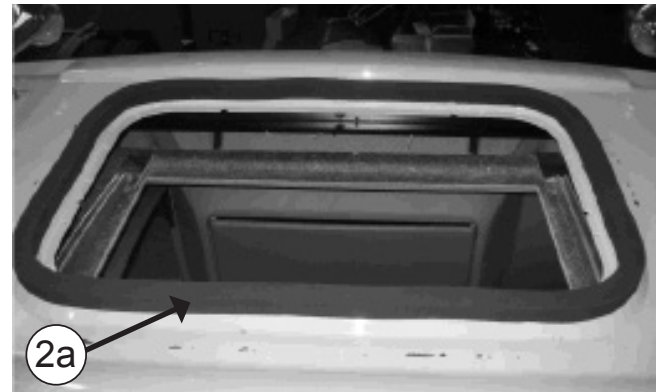

WIE DIE EPDM-DICHTUNG GESCHNITTEN A WIRD, UM WASSERUNDICHTIGKEITEN IN DIE KABINE ZU VERMEIDEN

- A-** Dichtung aufkleben und dabei einen Papierschutz von 100 mm auf jeder Seite beibehalten.
- B-** Die zwei Papierstücke entfernen.
- C-** Unter Anpressen beider Enden aufkleben.

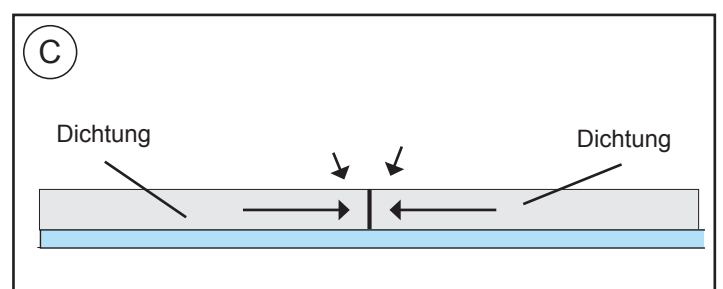
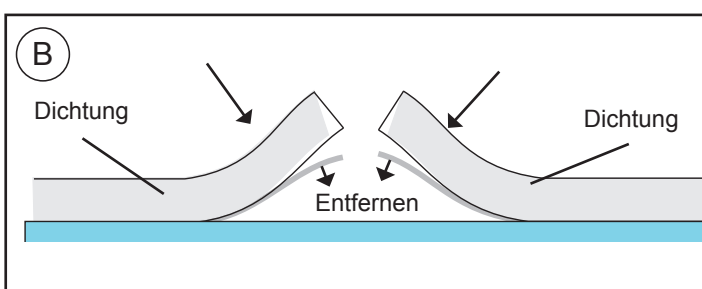
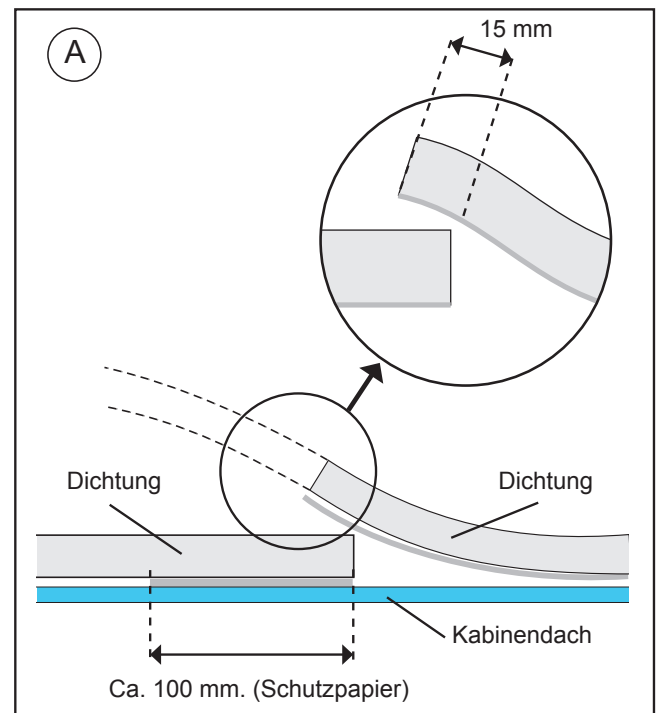

3 **KABINENAUSSENSEITE:**
Compact in der Lukenaussparung positionieren.
Achtung! Beim Auflegen des Geräts auf die Lukenaussparung darauf achten, dass die **Ablassausgänge** nicht von der **EPDM-Dichtung** zusammengedrückt werden.

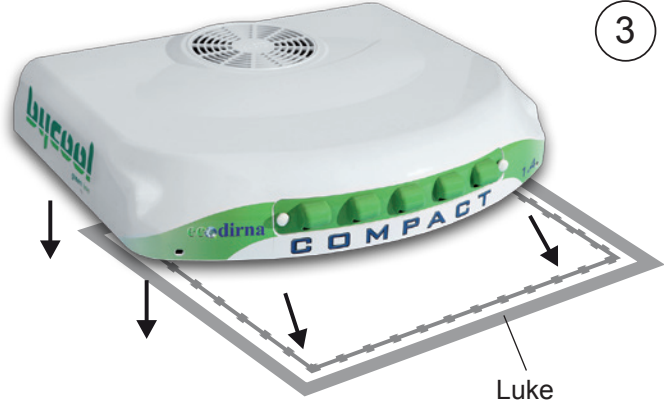

4 Schaumgummidurchführung anbringen, wobei der weichere Teil auf der Gerätegrundplatte aufliegt.
Achtung: Je nach Kabine kann es erforderlich sein, die (2) mitgelieferten Führungen zu verwenden, damit die Luftverteiltertafel ordnungsgemäß ausgerichtet ist.

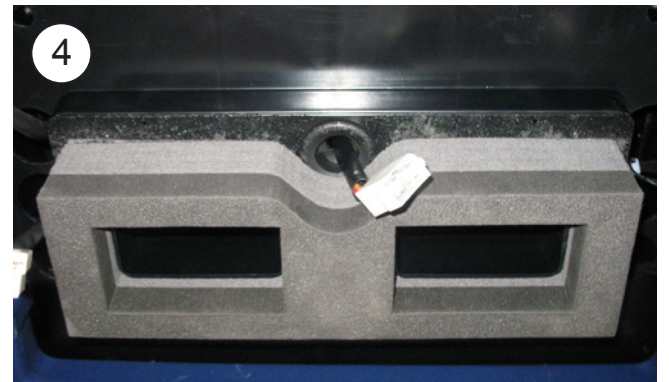

5 (4) Gummiunterlegscheiben \varnothing 6, (4) Breitflansch-Flachscheiben \varnothing 6 auf die Sechskant-Abstandshalter $L=43$ legen. Danach Sechskant-Abstandshalter anziehen, bis die Gummiunterlegscheibe ein wenig zusammengedrückt wird.

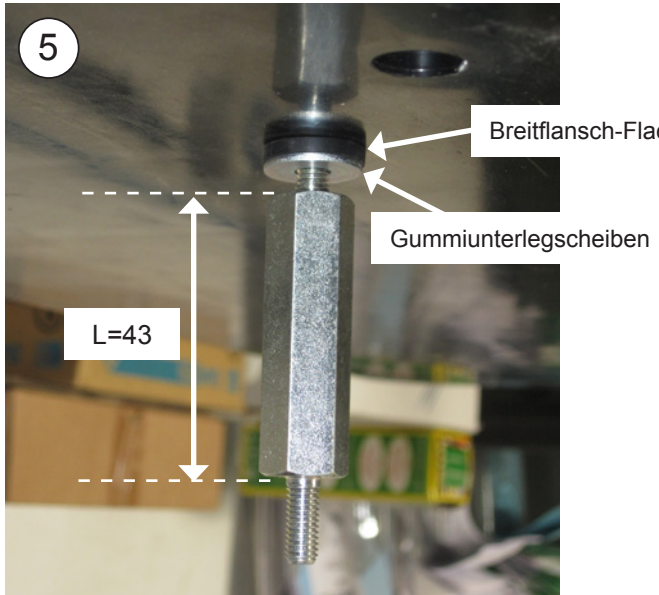
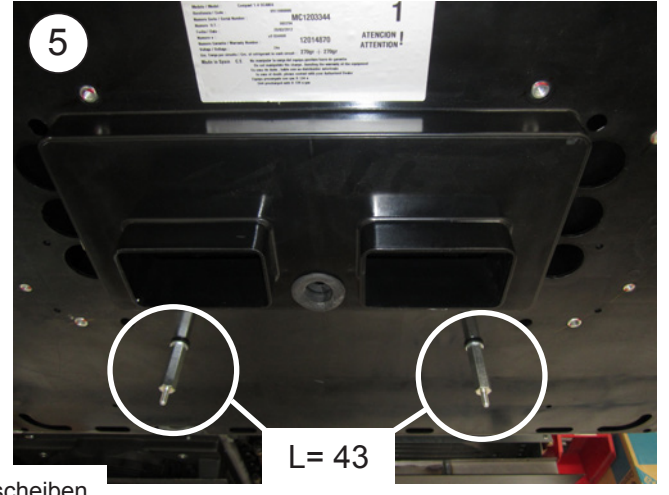

6 Den 2-Wege-Kasten des Abluftsensors, den 4-Wege-Kasten des Gebläses und den 8-Wege-Kasten der Kabel der Elektroniksteuerung anschließen.

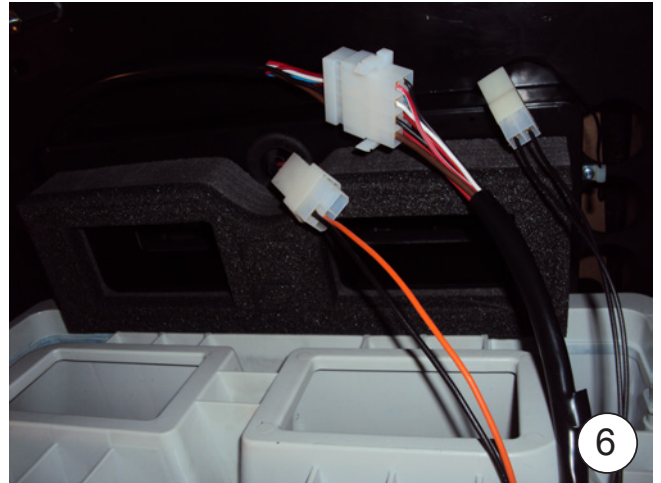

7 Innere Luftverteiltertafel an den oben genannten Sechskant-Abstandshaltern außen-außen anlegen und mit (4) Muttern M6 mit Unterlegscheibe und (4) Sechskant-Abstandshaltern innen-innen L=64 befestigen.

Wichtiger Hinweis: Die Schaumstoffführung muss an den oberen Schaumstoff der Anlage stoßen, um das Entweichen von Luft zu vermeiden.

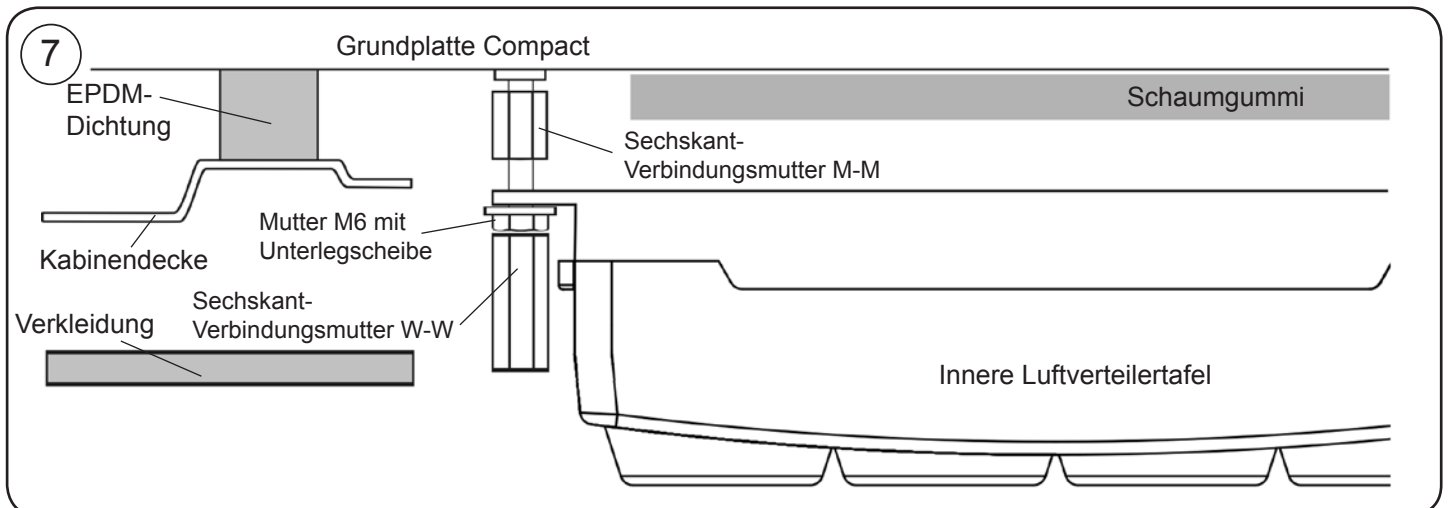
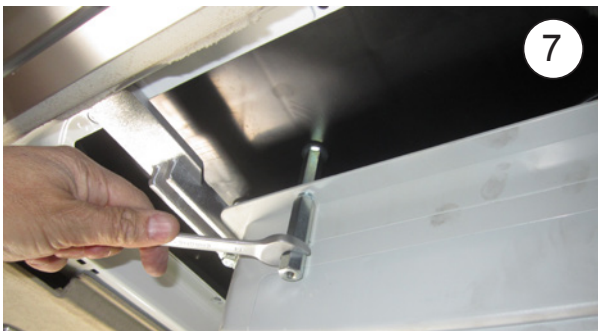
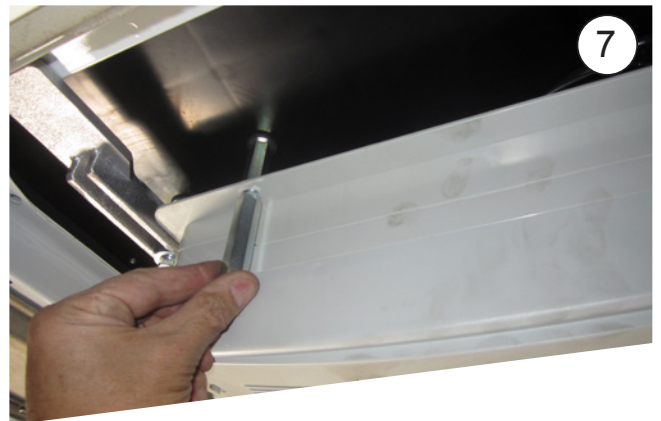

- 8** (4) Sechskant-Abstandshalter L=26 in die Einsätze des Gerätesockels mit Gummi-Unterlegscheibe und Flachscheibe auf $12,7 \pm 10\%$ Nm anziehen.



- 9** Befestigungshalter mit (4) Schrauben 8/125x45, Flachscheibe, Grower-Scheibe **ohne Anziehen** aufsetzen.



- 10** Konsole auflegen und Gerät zentrieren. Hierbei dient die Gardinenschiene als Referenz (die Konsole muss an der Schiene anschlagen). Nach dem Zentrieren Konsole entfernen.



- 11** Befestigungshalter durch Anziehen der Schrauben M8/125x45 fixieren.



12 Konsole mit (4) Schrauben M6/100x16 anbringen.



Explosionsansicht bis zur Befestigung der Halterungen

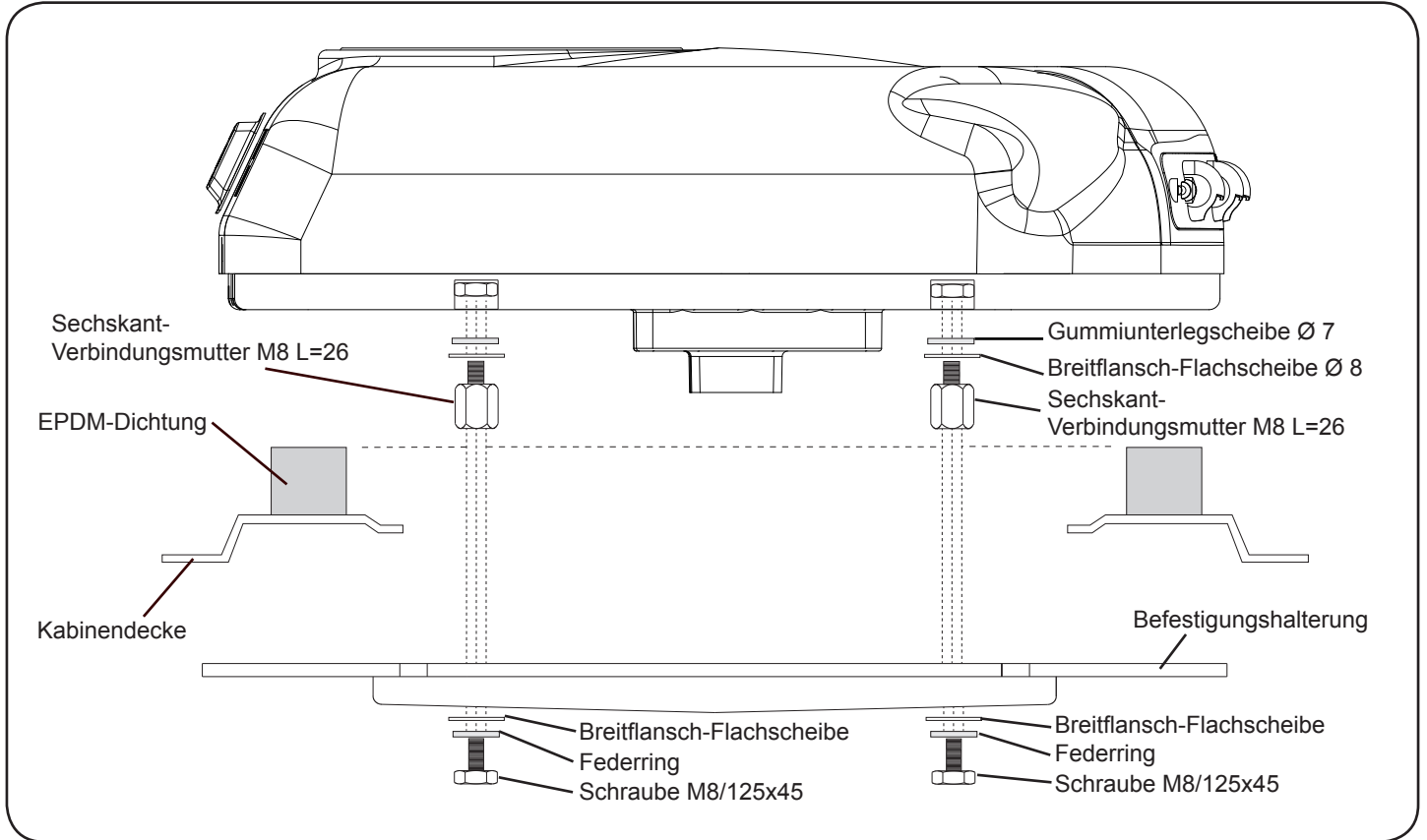

Explosionsansicht bis zur Befestigung der Konsolen

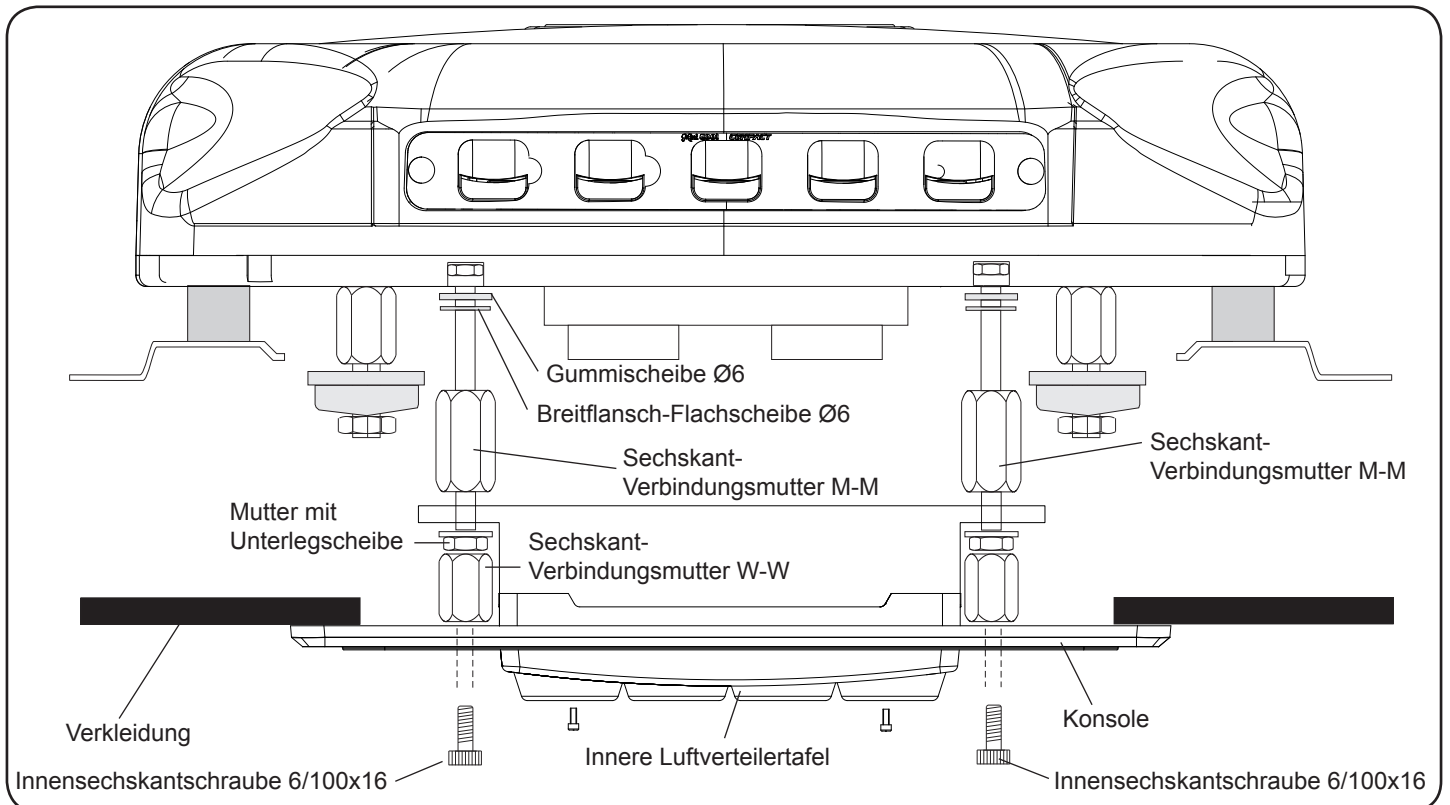

DETAILLIERTE HINWEISE ZUM ANSCHLUSS DES NETZKABELS

- 1** Netzkabel an das Gerät anschließen, an der Decke mit Klebehaltern und Kabelhaltern befestigen. Danach die Kabel über die Rückseite der Kabine nach unten führen.

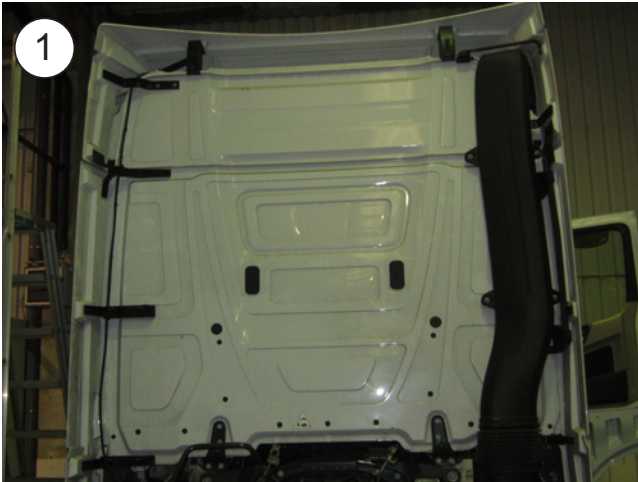

- 2** Das andere Ende des Kabels anschließen und das positive Kabel (blau) zum Anschlusskasten Position X4 führen.
Hinweis: Je nach dem Standort des Anschlusskastens ist das positive Kabel zu lang. Auf die gewünschte Länge kürzen.

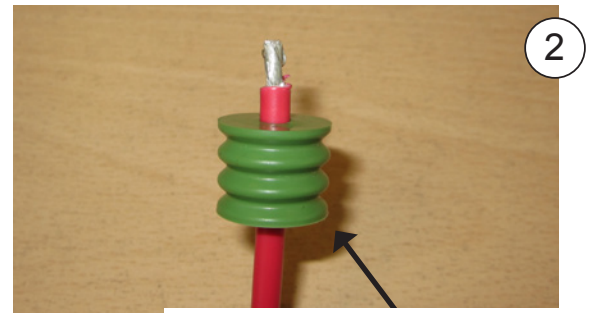

Kabel durch das mitgelieferte Gummiteil führen.

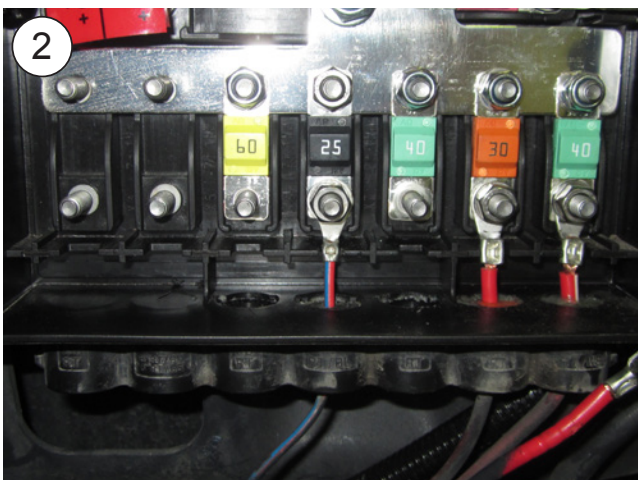

Kabel durch die Position X4 führen und Kabelschuh befestigen.

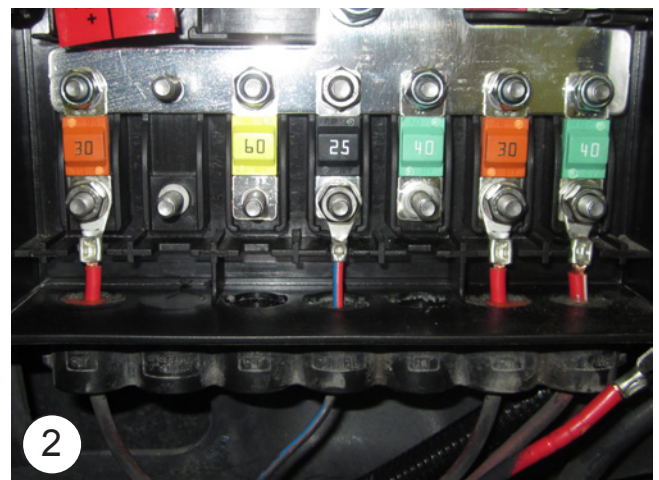

Mitgelieferte 30A Sicherung anbringen und mit Unterlegscheibe und Mutter befestigen.

3 Braunes Kabel (negativ) zum hierfür vorgesehenen Kasten führen.

Hinweis: Dieser befindet sich normalerweise in der Nähe der Batterien. Je nach dem Standort der Batterien ist das braune Kabel zu lang. Auf die gewünschte Länge kürzen und den mitgelieferten Kabelschuh anbringen.



4 Sicherheitsaufkleber der Kabel an sichtbarer Stelle anbringen, damit daran gedacht wird, dieses bei jedem Abklappen der Kabine abzuziehen.



WICHTIGER HINWEIS!

Darauf achten, dass die Polaritäten beim Anschluss des Geräts nicht vertauscht werden. Ist dies der Fall, schaltet sich das Bedienfeld nicht ein und das Gerät funktioniert nicht.

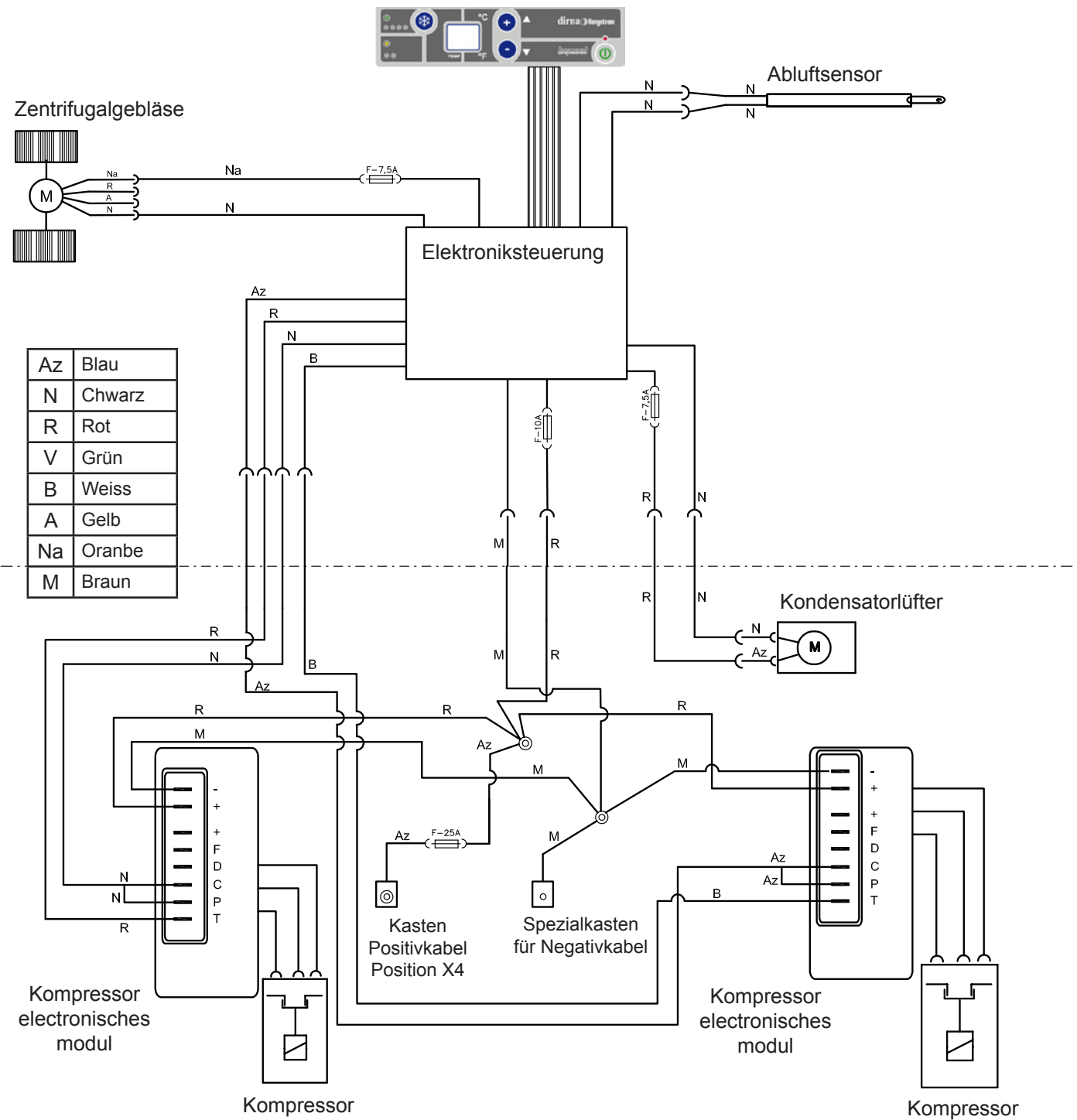

Suggerimenti per il montaggio

- Prima di cominciare il montaggio, leggere attentamente le istruzioni e rispettarle nel corso dello stesso.
- Usare gli attrezzi più adatti ad ogni operazione.

Elettricità

- Scollegare la chiave di contatto.
- Scollegare la batteria prima di cominciare il montaggio.
- Assicurarsi di avere effettuato correttamente l'installazione e il collegamento dei componenti elettrici.

Attenzione

Se durante il montaggio si inclina l'impianto, prima di rimetterlo in funzione occorre attendere almeno 60 minuti dal momento in cui è di nuovo in posizione orizzontale.

Attenzione

Quando si installa l'impianto di aria condizionata sul tettuccio, bisogna proteggere la parte superiore della cabina con uno straccio o una coperta per evitare eventuali graffi. Per l'installazione del **Compact**, tenere presente che normalmente le cabine munite di oblò dispongono di una struttura abbastanza solida per sostenere il peso dell'impianto. Tuttavia, se così non fosse e se fosse necessario tagliare il tettuccio, o se in presenza di oblò la struttura non fosse abbastanza rigida (se fosse di fibra, plastica, ecc.), è responsabilità dell'installatore decidere se occorre rinforzare il tettuccio per evitare qualsiasi deformazione, rottura o penetrazione d'acqua, ecc., prendendo le misure necessarie per evitarlo.

Attrezzi

Kit di chiavi Torx
 Kit di chiavi Allen
 Chiave fissa 10, 13, 14
 Forbici
 Metro a nastro

Documenti correlati

Istruzioni di montaggio	1001207475
Guida dell'utente	220AA60170
Soluzione dei problemi	220AA60013
Parti fornite	220AA10017
Garanzia	220.AA1.0017

Simbologia



Fragile



Attenzione alle mani



Tensione elettrica pericolosa

Avvertenze



L'installatore deve essere in possesso della formazione necessaria in materia di aria condizionata per veicoli.



dirna Bergstrom, s.l. declina ogni responsabilità per danni o rotture derivanti dall'errata installazione o dall'errato uso dell'impianto o da sostituzioni o modifiche effettuate senza la necessaria autorizzazione per iscritto.



Impianto precaricato con gas refrigerante. (Non manomettere il circuito di gas refrigerante).



Vedi la **procedura di garanzia** del prodotto in **Diagnosi dei problemi**.



Vedi la **Guida dell'utente** dell'impianto per il corretto funzionamento del telecomando e del pannello di controllo.



I seguenti documenti devono essere consegnati all'utente una volta conclusa l'installazione: **Guida dell'utente, Garanzia e Diagnosi dei problemi**.

 Prima di cominciare il montaggio, montare la griglia anteriore d'entrata dell'aria.



1 Smontare il coperchio del tettuccio apribile e gli elementi di fissaggio e consegnarli al cliente.

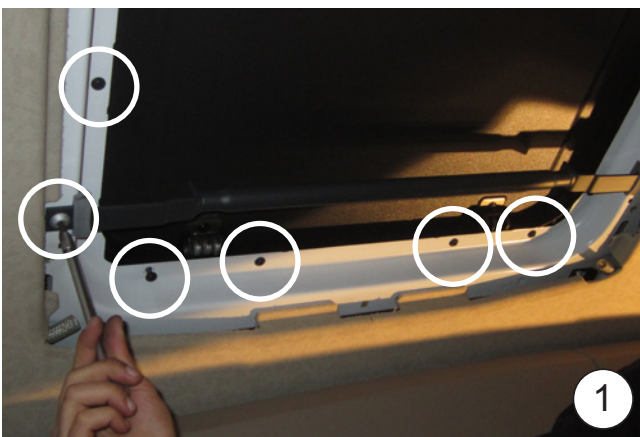
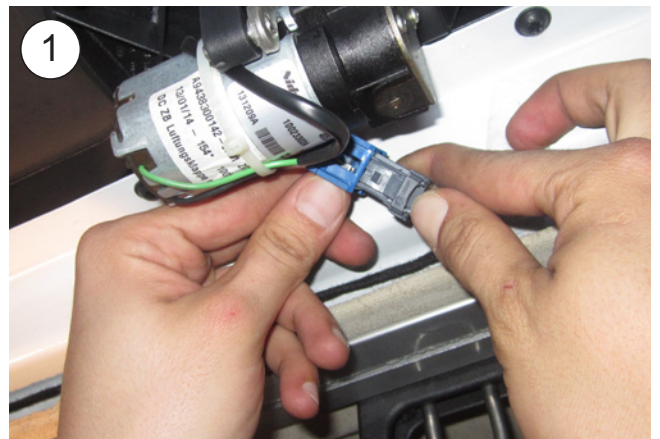
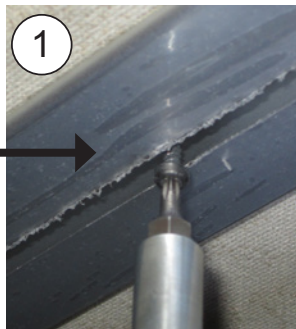
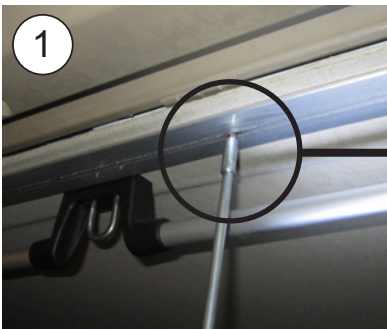
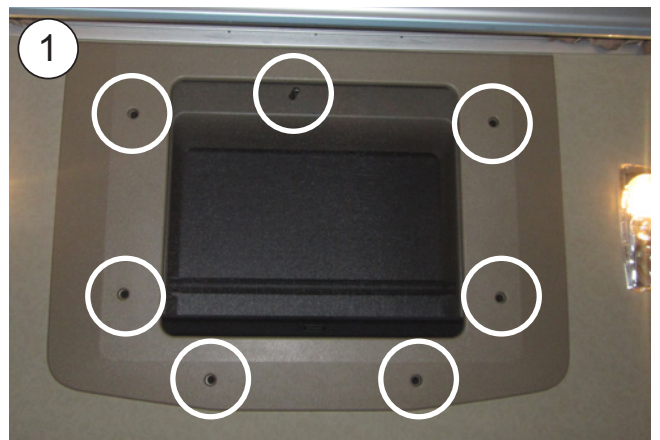
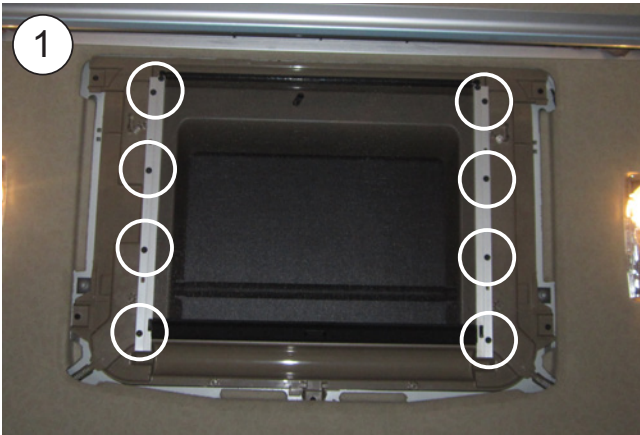

2 Se il veicolo ha lo spoiler con la barra centrale, per installare l'impianto occorre tagliare la barra come indicato dal tratteggio.



2a Incollare la guarnizione in EPDM intorno al vano del tettuccio apribile (vedi il particolare per tagliare le estremità della guarnizione).

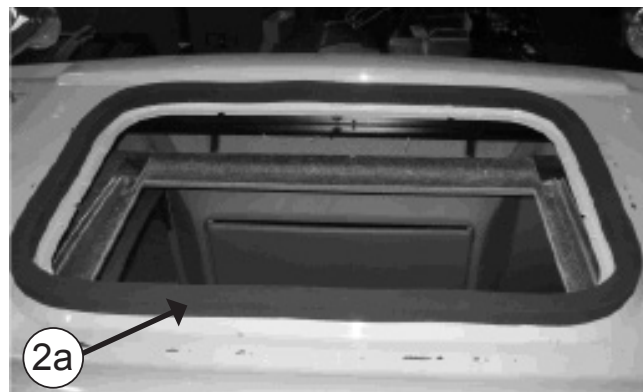

COME TAGLIARE LA GUARNIZIONE EPDM PER EVITARE INFILTRAZIONI NELLA CABINA

- A-** Incollare la guarnizione mantenendo una protezione di carta di 100 mm su ogni lato.
- B-** Rimuovere i due pezzi di carta.
- C-** Incollare premendo su entrambe le estremità.

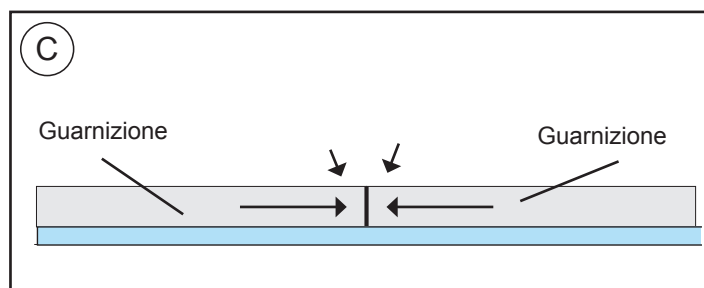
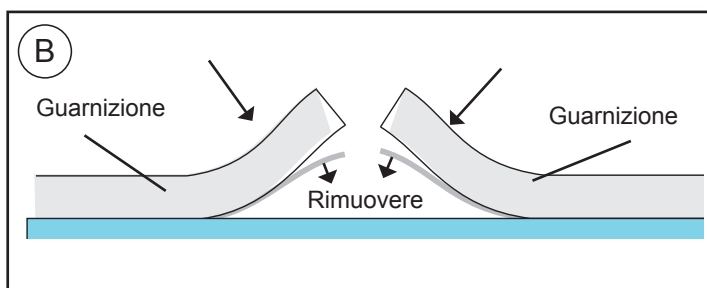
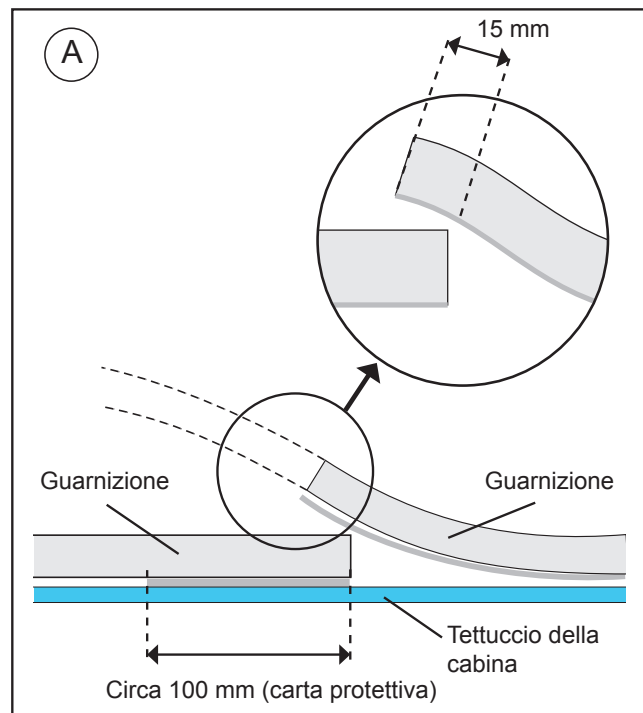

3 ESTERNO CABINA:
 Inserire il Compact nel vano del tettuccio apribile.
Attenzione! Quando si sistema l'impianto nel vano del tettuccio apribile, accertarsi che le uscite di scarico non siano ostruite dalla guarnizione EPDM.

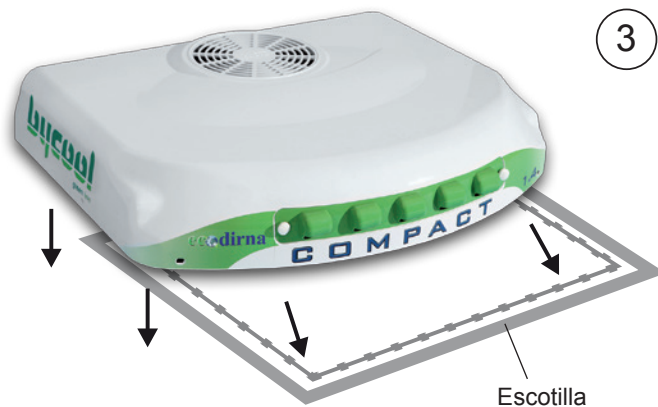

4 Posizionare il canalizzatore di gommapiuma con la parte più morbida sulla base dell'impianto.
Attenzione: A seconda della cabina, può essere necessario usare i (2) canalizzatori in dotazione per la completa adesione del pannello di distribuzione dell'aria ai medesimi.



5 Inserire (4) rondelle Ø 6 di gomma, (4) rondelle piane Ø 6 a testa larga sui perni esagonali L=43. Stringere i perni esagonali fino a schiacciare leggermente la rondella di gomma.

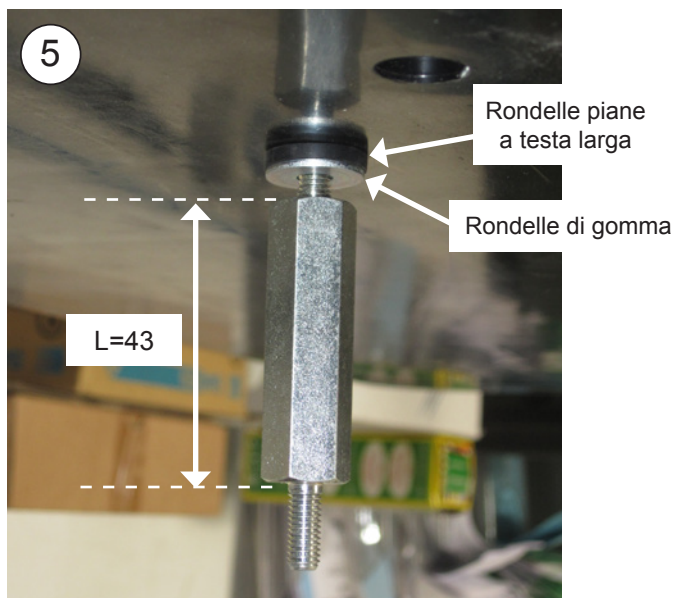
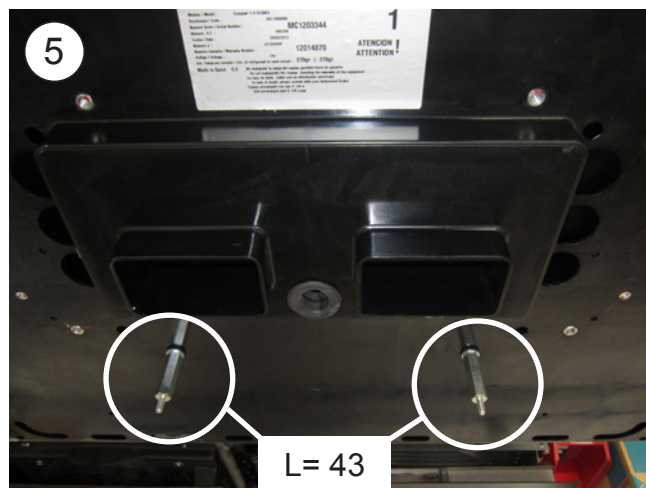

6 Collegare la scatola a 2 vie del sensore dell'aria di ritorno, la scatola a 4 vie del ventilatore e quella a 8 vie di connessione dei cablaggi del controllo elettronico.

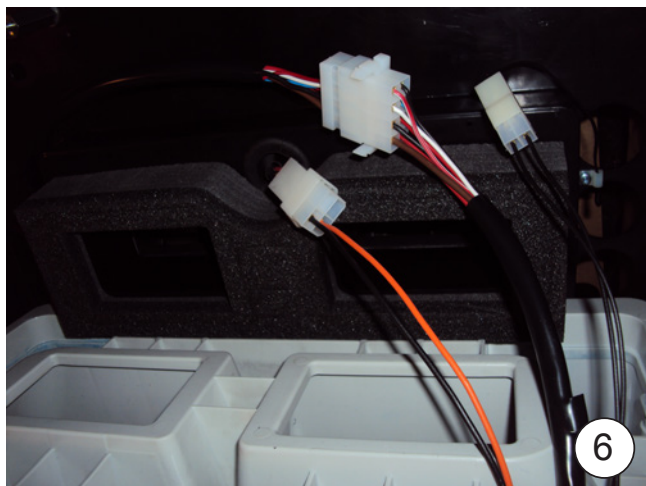

7 Posizionare il pannello interno di distribuzione dell'aria sui perni esagonali M-M anteriori e fissare con (4) dadi M6 con rondella e (4) perni esagonali F-F L=64.

Nota bene: il canalizzatore di gommapiuma deve essere a battuta sulla gommapiuma superiore dell'impianto per evitare perdite d'aria.

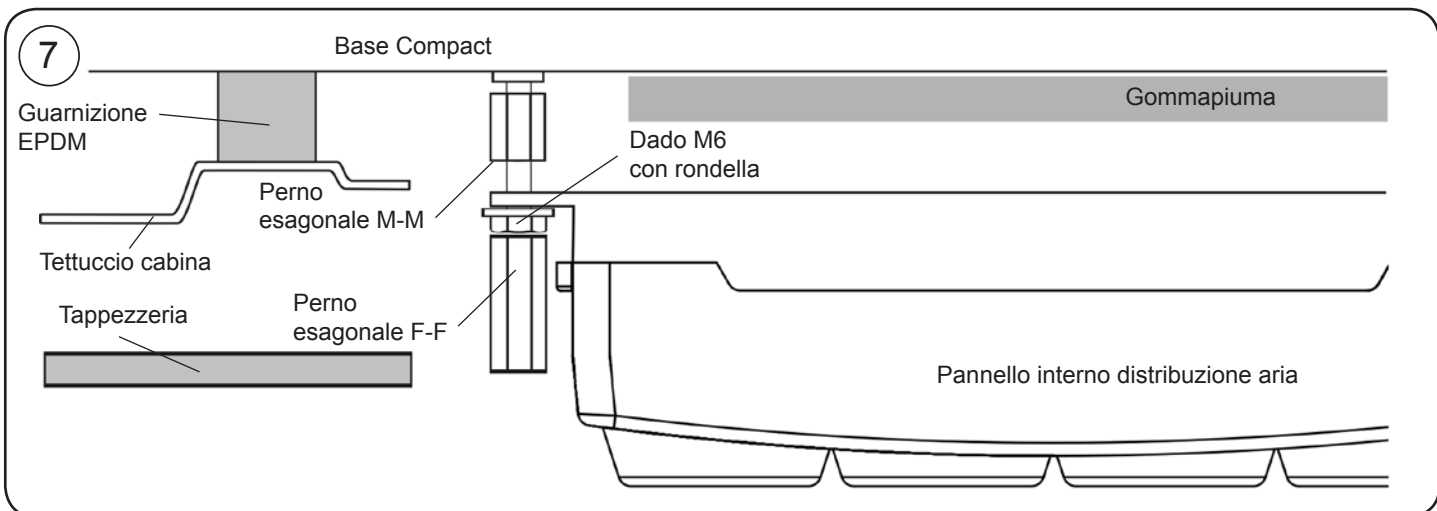
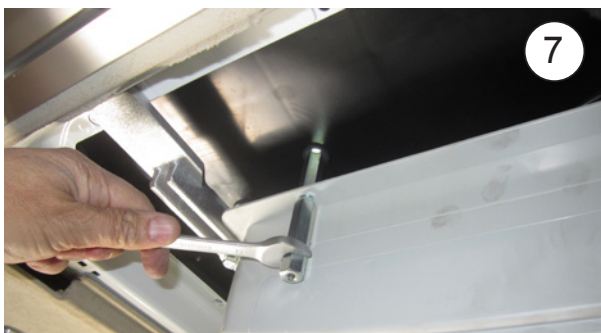
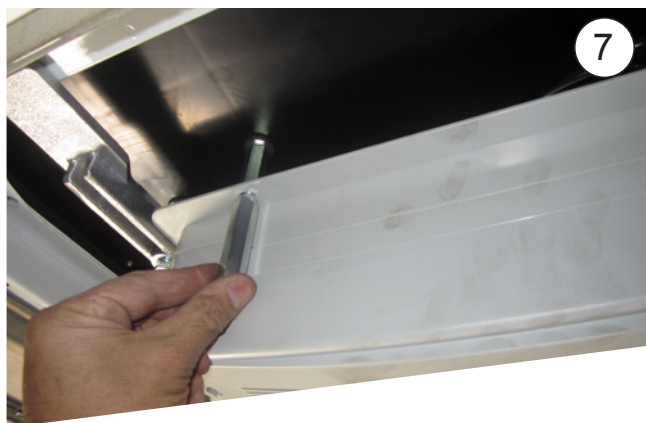

- 8** Avvitare (4) perni esagonali L=26 sugli inserti della base dell'impianto con rondella di gomma e rondella piana e stringere con una coppia di serraggio di $12,7 \pm 10\%$ Nm.



- 9** Inserire i supporti di fissaggio con (4) viti 8/125x45 con rondella piana, rondella grower, **senza stringere**.



- 10** Sistemare provvisoriamente la console e centrare l'impianto prendendo come riferimento il binario della tendina (la console deve essere a battuta contro il binario). Una volta centrata, rimuovere la console.



- 11** Fissare i supporti di fissaggio stringendo le viti M8/125x45.



12 Fissare la console con (4) viti M6/100x16.



Esplso fino al fissaggio dei supporti

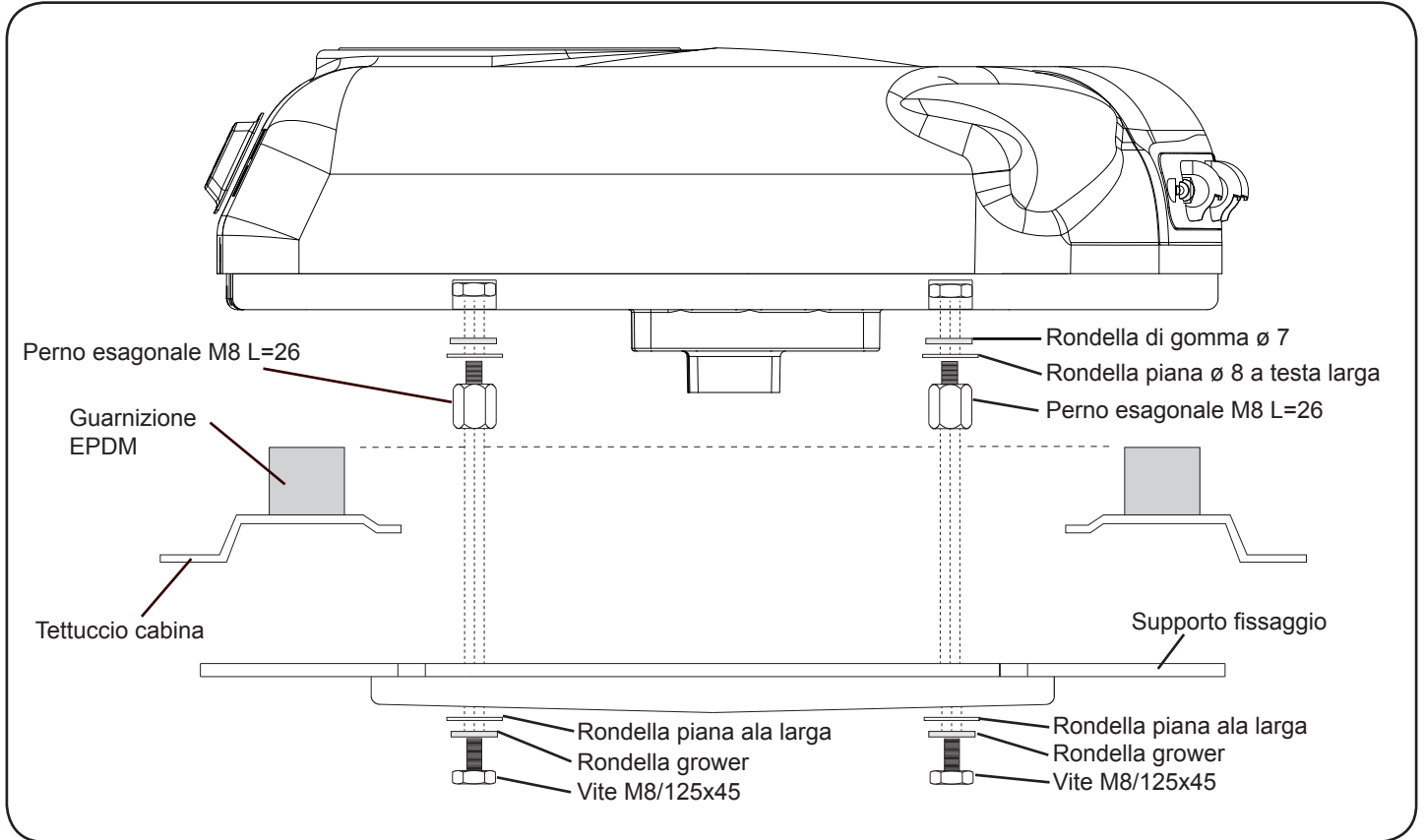

Esplso fino al fissaggio della console

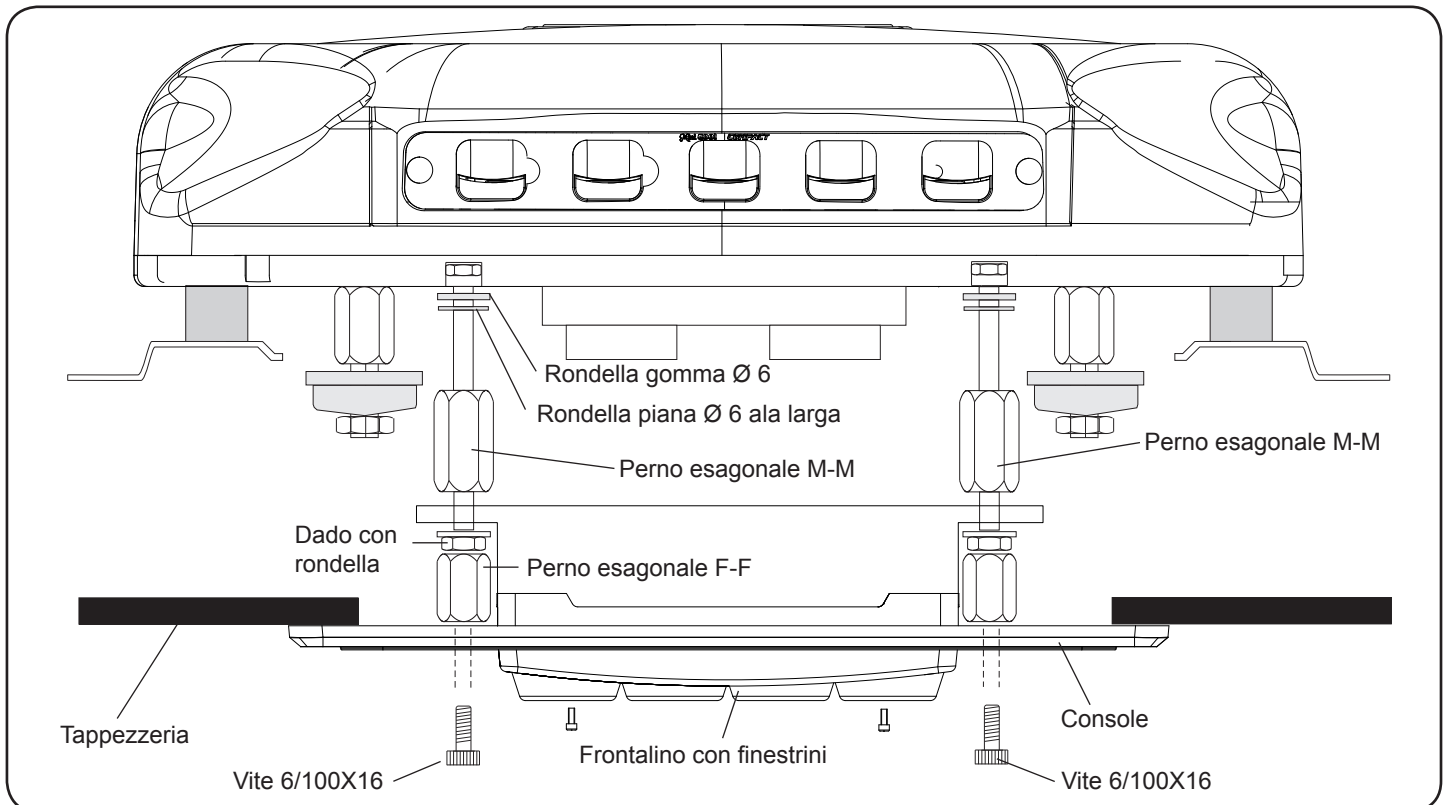

ISTRUZIONI PARTICOLAREGGIATE SULLA CONNESSIONE DEL CABLAGGIO DI ALIMENTAZIONE

- 1** Collegare il cavo di alimentazione al gruppo, fissarlo al tettuccio con i supporti adesivi e le fascette. Far passare il cablaggio dalla parte posteriore della cabina.

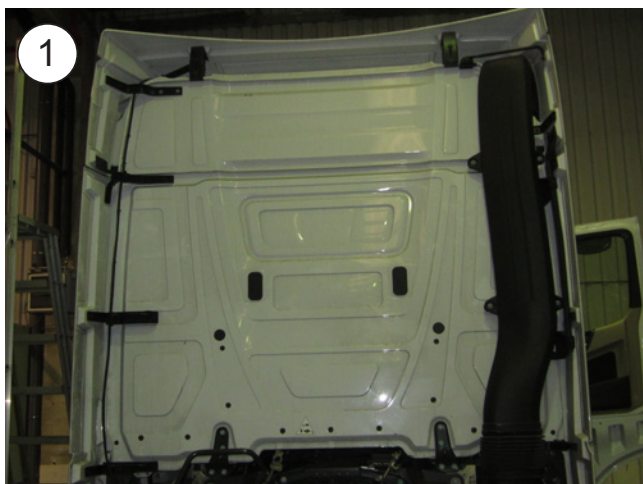

- 2** Collegare l'altra estremità del cablaggio e portare il cavo positivo (blu) alla scatola delle connessioni in posizione X4.

Nota: a seconda dell'ubicazione della scatola delle connessioni, il cavo positivo è più lungo del necessario. Occorre perciò tagliarlo alla lunghezza richiesta.



Inserire il cablaggio nella guaina in dotazione

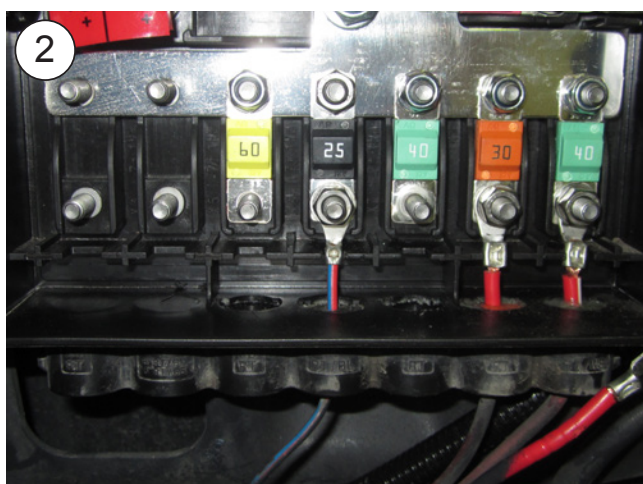

Far passare il cablaggio dalla posizione X4 e fissare il terminale

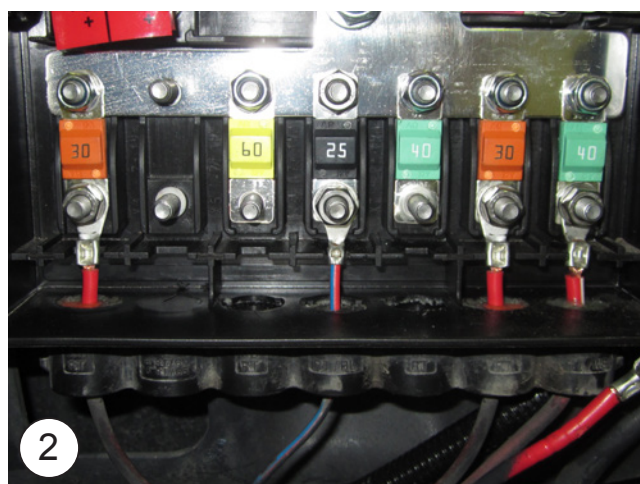

Montare il fusibile da 30 A in dotazione e fissare con la rondella e il dado

3 Portare il cavo marrone (negativo) all'apposita scatola.

Nota: normalmente è vicino alle batterie. A seconda dell'ubicazione delle batterie il cavo marrone è più lungo del necessario e quindi occorre tagliarlo alla misura richiesta e fissare il terminale in dotazione.

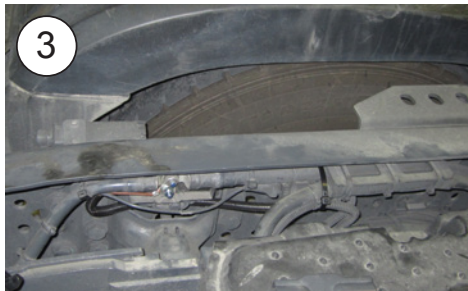

4 Attaccare gli adesivi di sicurezza del cablaggio in un sito visibile per ricordare che bisogna disinsierirlo ogni volta che si desidera ribaltare la cabina.



Cablaggio elettrico

AVVERTENZA IMPORTANTE!

Fare attenzione a non invertire le polarità quando si esegue il collegamento dell'impianto. Infatti, in tal caso il quadro comandi non si accende e l'impianto non funziona.

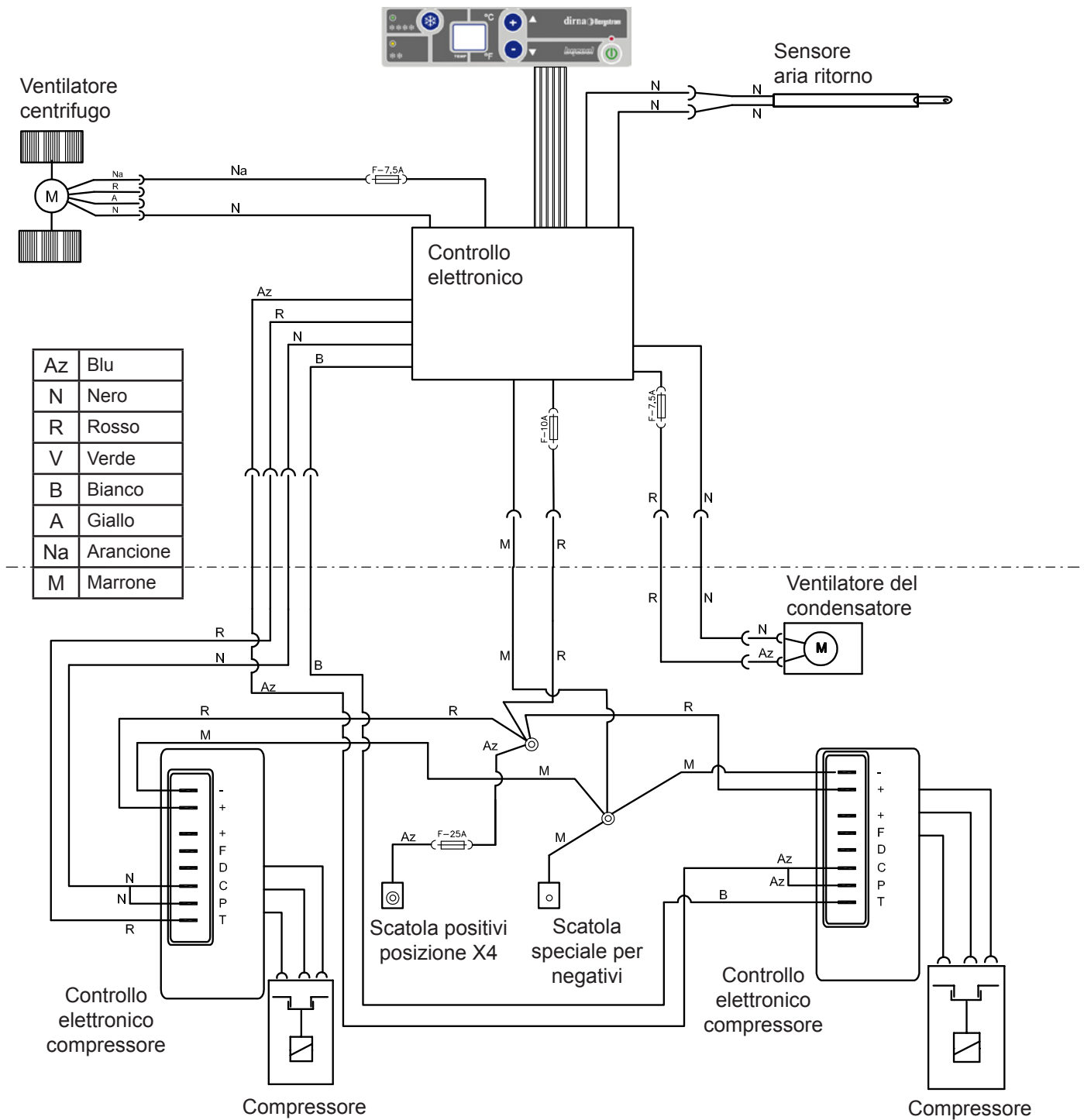

Ed:	11/01/2016
Md:	10/07/2019

b



Francisco Alonso, 6
28806 Alcalá de Henares, Madrid
SPAIN

Contact	Phone	Fax	E-Mail
Sales (Ventas Internacional)	+34 91 8770510	+34 91 8771158	sales@dirna.bergstrominc.com
Comercial Nacional	+34 91 8775841	+34 91 8836321	ventas@dirna.bergstrominc.com
Orders & Deliveries (Logística internacional)	+34 91 8775846	+34 91 8771158	export@dirna.bergstrominc.com
Orders & Deliveries (Logística nacional)	+34 91 8775840	+34 91 8836321	comercial@dirna.bergstrominc.com
Technical Assistance (Internacional)	+49 511 86679681	+49 511 86679710	technicalassistance@dirna.bergstrominc.com
Technical Assistance (Nacional)	+34 91 8775845	+34 91 883 6321	oblanco@dirna.bergstrominc.com

www.dirna.com

	ATENCIÓN:	Dirna Bergstrom se reserva el derecho de efectuar modificaciones en cualquier momento de los datos contenidos en esta publicación, por razones técnicas o comerciales.
	NOTE:	<i>For technical and commercial reasons, Dirna Bergstrom reserves the right to change the data contained in this brochure.</i>
	ATTENTION:	Dirna Bergstrom se réserve le droit d'effectuer à tout moment des modifications des données reprises sur cette publication, pour des raisons techniques ou commerciales.
	HIWEIS:	<i>Dirna Bergstrom behält sich vor, aus technischen oder kaufmännischen Gründen jederzeit Änderungen der Angaben dieser Veröffentlichung vorzunehmen.</i>
	ATTENZIONE:	Dirna Bergstrom si riserva il diritto di effettuare modifiche in qualsiasi momento ai dati contenuti in questa pubblicazione, per motivi tecnici o commerciali.